



Standard Test Method for Resistance to Plastic Flow of Bituminous Mixtures Using Marshall Apparatus (6 inch-Diameter Specimen)¹

This standard is issued under the fixed designation D 5581; the number immediately following the designation indicates the year of original adoption or, in the case of revision, the year of last revision. A number in parentheses indicates the year of last reapproval. A superscript epsilon (ϵ) indicates an editorial change since the last revision or reapproval.

1. Scope

1.1 This test method covers the measurement of the resistance to plastic flow of cylindrical specimens of bituminous paving mixture loaded on the lateral surface by means of the Marshall apparatus. This test method is for use with mixtures containing asphalt cement and aggregate up to 1½ in. (37.5 mm) nominal maximum size.

1.2 The values stated in inch-pound units are to be regarded as standard except for reference to sieve sizes and size of aggregate as measured by testing sieves in which SI units are standard according to Specification E 11. The SI equivalent shown in parentheses may be approximate.

1.3 *This standard does not purport to address all of the safety concerns, if any, associated with its use. It is the responsibility of the user of this standard to establish appropriate safety and health practices and determine the applicability of regulatory limitations prior to use.*

2. Referenced Documents

2.1 ASTM Standards:

C 670 Practice for Preparing Precision and Bias Statements for Test Methods for Construction Materials²

D 1559 Test Method for Resistance to Plastic Flow of Bituminous Mixtures Using Marshall Apparatus³

E 11 Specification for Wire Cloth and Sieves for Testing Purposes⁴

3. Significance and Use

3.1 This test method is used in the laboratory mix design of bituminous mixtures. Specimens are prepared in accordance with the method and tested for maximum load and flow. Density and voids properties may also be determined on specimens prepared in accordance with the method. The testing section of this method can also be used to obtain maximum load and flow for bituminous paving specimens cored from pavements or prepared by other methods. These results may

differ from values obtained on specimens prepared by this test method.

3.2 It has been determined that 75 and 112 compaction blows applied to a 6-in. (152.4 mm) diameter specimen using the apparatus and procedure in this standard give densities equivalent to 50 and 75 compaction blows, respectively, applied to a 4-in. (101.6 mm) diameter specimen using Test Method D 1559.

4. Apparatus

4.1 *Specimen Mold Assembly*—Mold cylinders nominal 6.5 in. (165.1 mm) outside diameter steel tubing with 6.000 ± 0.008 in. (152.4 ± 0.2 mm) inside diameter by 4.5 in. (114.3 mm) in height, base plates, and extension collars shall conform to the details shown in Fig. 1. Nine mold cylinders are recommended.

4.2 *Specimen Extractor*—steel, in the form of a disk with a diameter from 5.950 to 5.990 in. (151.1 to 152.1 mm) and 0.5 in. (13 mm) thick for extracting the compacted specimen from the specimen mold with the use of the mold collar. A suitable bar is required to transfer the load from the ring dynamometer adapter to the extension collar while extracting the specimen.

4.3 *Mechanical Compactor and Compaction Hammer*—Compactor with ⅓ hp (250W) minimum motor, chain lift, frame, and automatic sliding weight release. The compaction hammer (Fig. 2) shall have a flat, circular tamping face 5.88 in. (149.4 mm) in diameter and a 22.50 ± 0.02 lb (10.21 ± 0.01 kg) sliding weight with a free fall of 18.0 ± 0.1 in. (457.2 ± 2.5 mm). Two compaction hammers are recommended.

4.4 *Compaction Pedestal*—The compaction pedestal shall consist of an 8 by 8 by 18-in. (203.2 by 203.2 by 457.2-mm) wooden post capped with a 12 by 12 by 1-in. (304.8 by 304.8 by 25.4-mm) steel plate. The wooden post shall be oak, pine, or other wood having an average dry weight of 42 to 48 lb/ft³ (0.67 to 0.77 g/cm³). The wooden post shall be secured by four angle brackets to a solid concrete slab. The steel cap shall be firmly fastened to the post. The pedestal assembly shall be installed so that the post is plumb and the cap is level.

4.5 *Specimen Mold Holder*—mounted on the compaction pedestal so as to center the compaction mold over the center of the post as shown in Fig. 3 or equivalent arrangement. It shall hold the compaction mold, collar, and base plate securely in position during compaction of the specimen.

¹ This test method is under the jurisdiction of ASTM Committee D04 on Road and Paving Materials and is the direct responsibility of Subcommittee D04.20 on Mechanical Tests of Bituminous Mixes.

Current edition approved Jan. 10, 1996. Published March 1996. Originally published as D 5581 – 94. Last previous edition D 5581 – 94.

² *Annual Book of ASTM Standards*, Vol 04.02.

³ *Annual Book of ASTM Standards*, Vol 04.03.

⁴ *Annual Book of ASTM Standards*, Vol 14.02.

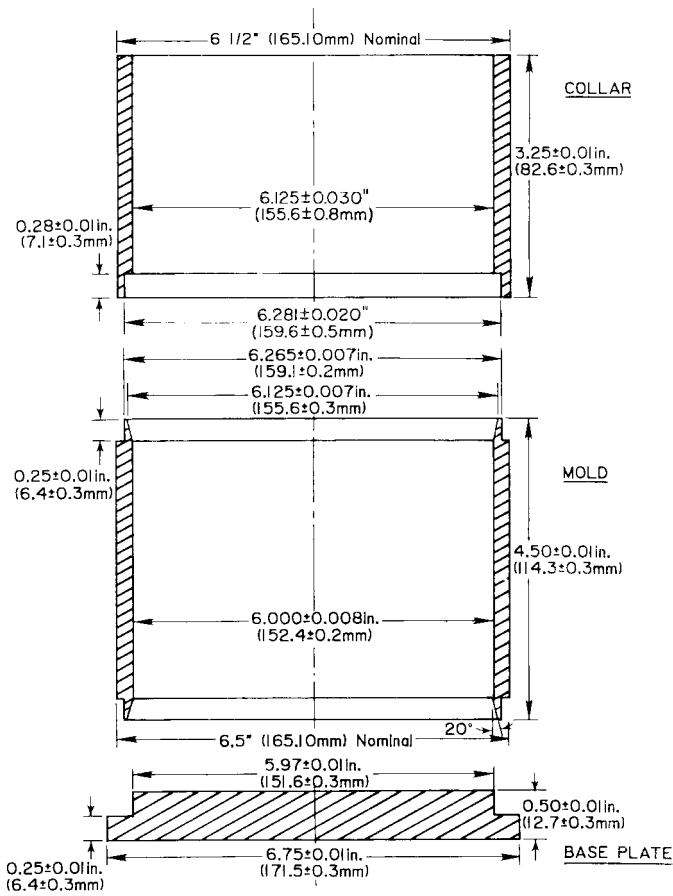

Note: collar should fit the mold.

FIG. 1 Compaction Mold

4.6 *Breaking Head*—The breaking head (Fig. 4) shall consist of upper and lower cylindrical segments or test heads having an inside radius of curvature of 3 in. (76.2 mm) accurately machined. The lower segment shall be mounted on a base having two perpendicular guide rods or posts extending upward. Guide sleeves in the upper segments shall be in such a position as to direct the two segments together without appreciable binding or loose motion on the guide rods. When a 6.000 in. (152.4 mm) diameter by 4 in. (100 mm) thick metal block is placed between the two segments, the inside diameters and the gaps between the segments shall conform to Fig. 4. All steel components shall be plated.

4.7 *Loading Jack*—The loading jack (Fig. 5) shall consist of a screw jack mounted in a test frame and shall produce a uniform vertical movement of 2 in. (50.8 mm)/min. An electric motor may be attached to the jacking mechanism.

NOTE 1—Instead of the loading jack, a mechanical or hydraulic testing machine may be used provided the rate of movement can be maintained at 2 in. (50.8 mm)/min while the load is applied.

4.8 *Ring Dynamometer Assembly*—One ring dynamometer (Fig. 5) of 10 000-lb. (4536-kg) capacity and sensitivity of 10 lb (4.536 kg) up to 1000 lb (453.6 kg) and 25 lb (11.340 kg) between 1000 and 10 000 lb (453.6 and 4536 kg) shall be equipped with a micrometer dial. The micrometer dial shall be

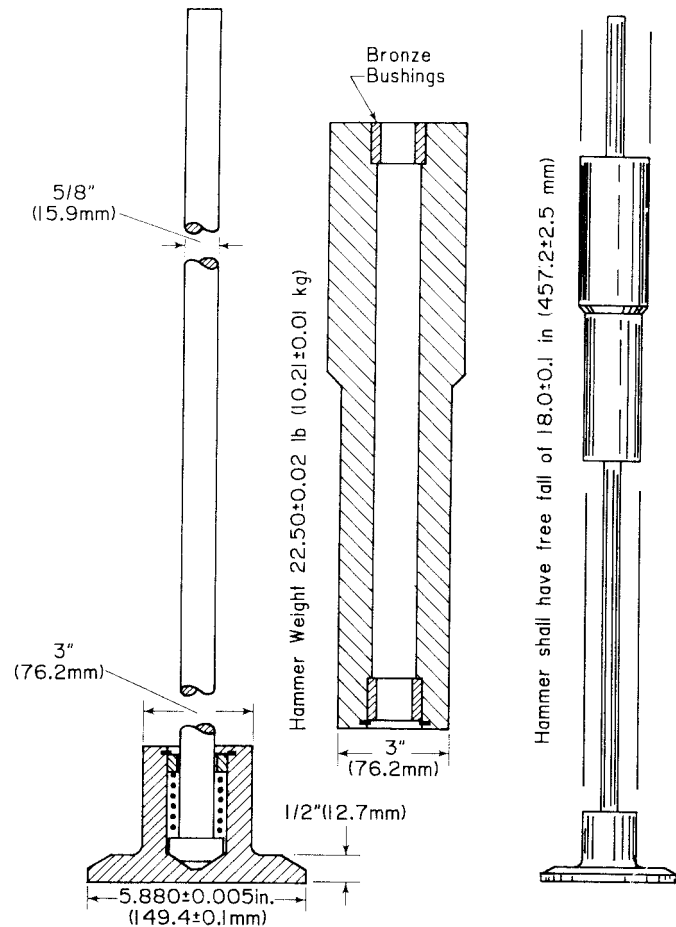

FIG. 2 Compaction Hammer (Generic)

graduated on 0.0001 in. (0.0025 mm). Upper and lower ring dynamometer attachments are required for fastening the ring dynamometer to the testing frame and transmitting the load to the breaking head.

NOTE 2—Instead of the ring dynamometer assembly, any suitable load-measuring device may be used provided the capacity and sensitivity meet the above requirements.

4.9 *Flowmeter*—The flowmeter shall consist of a guide sleeve and a gage. The activating pin of the gage shall slide inside the guide sleeve with a slight amount of frictional resistance. The guide sleeve shall slide freely over the guide rod of the breaking head. The flowmeter gage shall be adjusted to zero when placed in position on the breaking head when each individual test specimen is inserted between the breaking head segments. Graduations of the flowmeter gage shall be in 0.01-in. (0.25-mm) divisions.

NOTE 3—Instead of the flowmeter, a micrometer dial or stress-strain recorder graduated in 0.001 in. (0.025-mm) may be used to measure flow.

4.10 *Ovens or Hot Plates*—Ovens or hot plates shall be provided for heating aggregates, bituminous material, specimen molds, compaction hammers, and other equipment to the required mixing and molding temperatures. It is recommended that the heating units be thermostatically controlled so as to maintain the required temperature within 5°F (2.8°C). Suitable shields, baffle plates or sand baths shall be used on the surfaces of the hot plates to minimize localized overheating.

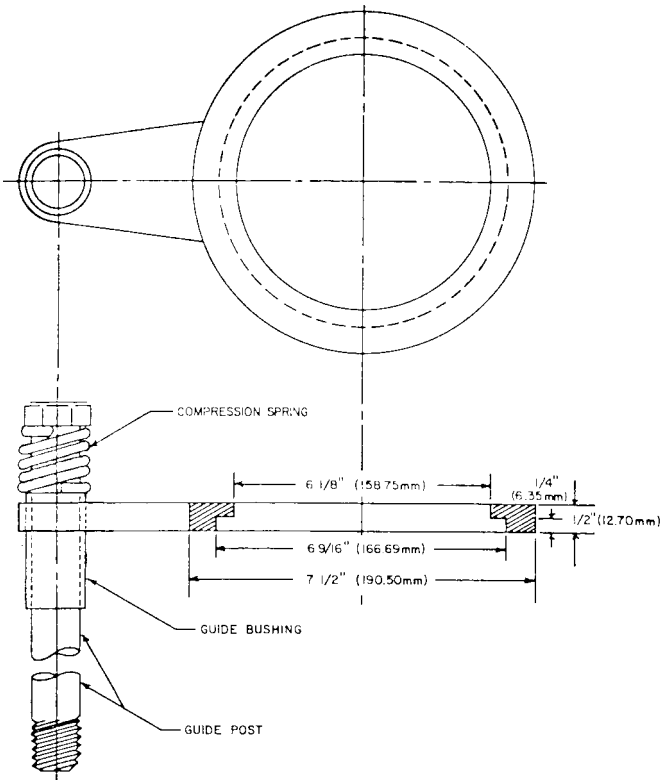

FIG. 3 Specimen Mold Holder

NOTE: GUIDE POST THREADED INTO PEDESTAL CAP DIMENSIONS OF GUIDE POST, GUIDE BUSHING AND COMPRESSION SPRING NOT CRITICAL. ONLY REQUIREMENT IS THAT COMPACTION MOLD IS HELD FIRMLY.

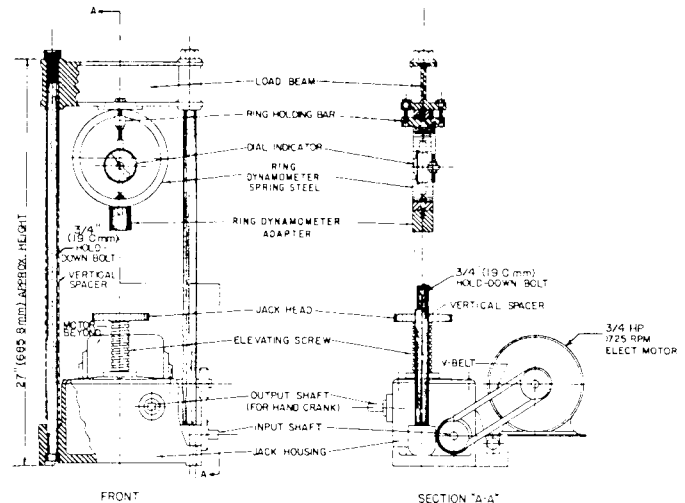

FIG. 5 Compression Testing Machine

(228.6 mm) deep and shall be thermostatically controlled so as to maintain the bath at $140 \pm 1.8^\circ\text{F}$ ($60 \pm 1.0^\circ\text{C}$). The tank shall have a perforated false bottom or be equipped with a shelf for supporting specimens 2 in. (50.8 mm) above the bottom of the bath.

4.13 *Miscellaneous Equipment:*

4.13.1 *Containers* for heating aggregates, flat-bottom metal pans or other suitable containers.

4.13.2 *Containers* for heating bituminous material, either gill-type tins, beakers, pouring pots, or saucepans may be used.

4.13.3 *Mixing Tool*, either a steel trowel (garden type) or spatula, for spading and hand mixing.

4.13.4 *Thermometers* for determining temperatures of aggregates, bitumen, and bituminous mixtures. Armored-glass or dial-type thermometers with metal stems are recommended. A range from 50 to 400°F (9.9 to 204°C), with sensitivity of 5°F (2.8°C) is required.

4.13.5 *Thermometers* for water and air baths with a range from 68 to 158°F (20 to 70°C) sensitive to 0.4°F (0.2°C).

4.13.6 *Balance*, 10-kg capacity, sensitive to 1.0 g.

4.13.7 *Gloves* for handling hot equipment.

4.13.8 *Rubber Gloves* for removing specimens from water bath.

4.13.9 *Marking Crayons* for identifying specimens.

4.13.10 *Scoop*, flat bottom, for batching aggregates.

4.13.11 *Spoon*, large, for placing the mixture in the specimen molds.

5. Test Specimens

5.1 *Number of Specimens*—Prepare at least three specimens for each combination of aggregates and bitumen content.

5.2 *Preparation of Aggregates*—Dry aggregates to constant weight at $230 \pm 9^\circ\text{F}$ ($110 \pm 5^\circ\text{C}$) and separate the aggregates by dry sieving into the desired size fractions. The following size fractions are recommended:

- 2 to 1/2 in. (50 to 37.5 mm)
- 1 1/2 to 1 in. (37.5 to 25.0 mm)
- 1 to 3/4 in. (25.0 to 19.0 mm)
- 3/4 to 3/8 in. (19.0 to 9.5 mm)
- 3/8 in. to No. 4 (9.5 mm to 4.75 mm)

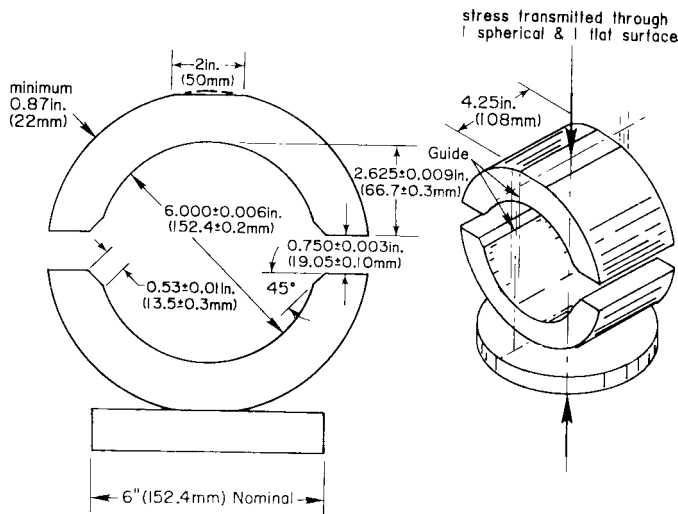

FIG. 4 Breaking Head

4.11 *Mixing Apparatus*—Mechanical mixing is recommended. Any type of mechanical mixer may be used provided it can be maintained at the required mixing temperature and will provide a well-coated, homogeneous mixture of the required amount in the allowable time, and further provided that essentially all of the batch can be recovered. A metal pan or bowl of sufficient capacity (such as standard 13 qt. size approximately 6 1/4 in. deep) and hand mixing may also be used.

4.12 *Water Bath*—The water bath shall be at least 9 in.

No. 4 to No. 8 (4.75 mm to 2.36 mm)
Passing No. 8 (2.36 mm)

5.3 Determination of Mixing and Compacting Temperatures:

5.3.1 The temperatures to which the asphalt cement and asphalt cut-back must be heated to produce a viscosity of 170 ± 20 cSt shall be the mixing temperature.

5.3.2 The temperature to which asphalt cement must be heated to produce a viscosity of 280 ± 30 cSt shall be the compacting temperature.

5.4 Preparation of Mixtures:

5.4.1 Weigh into separate pans for each test specimen the amount of each size fraction required to produce a batch that will result in a compacted specimen 3.75 ± 0.10 in. (95.2 ± 2.54 mm) in height (about 4050 g). Place the pans on the hot plate or in the oven and heat to a temperature not exceeding the mixing temperature established in 5.3 by more than approximately 50°F (28°C). Charge the mixing bowl with the heated aggregate and dry mix thoroughly. Form a crater in the dry blended aggregate and weigh the preheated required amount of bituminous material into the mixture. Care must be exercised to prevent loss of the mix during mixing and subsequent handling. At this point, the temperature of the aggregate and bituminous material shall be within the limits of the mixing temperature established in 5.3. Mix the aggregate and bituminous material rapidly until thoroughly coated. If the mix consists of absorptive aggregate place the mix in a covered container in an oven maintained at the mixing temperature for 4 h.

5.5 Compaction of Specimens:

5.5.1 Thoroughly clean the specimen mold assembly and the face of the compaction hammer and heat them either in boiling water or on the hot plate to a temperature between 200 and 300°F (93.3 and 148.9°C). Place a piece of filter paper or paper toweling cut to size in the bottom of the mold before the mixture is introduced. Place approximately one half of the batch in the mold, spade the mixture vigorously with a heated spatula or trowel 15 times around the perimeter and 10 times over the interior. Place the second half of the batch in the mold and repeat the foregoing procedure. Remove the collar and smooth the surface of the mix with a trowel to a slightly rounded shape. Place a piece of filter paper or paper toweling cut to size on top of the mix. Temperatures of the mixtures immediately prior to compaction shall be within the limits of the compacting temperature established in 5.3.

5.5.2 Replace the collar, place the mold assembly on the compaction pedestal in the mold holder, and unless otherwise specified, apply 75 blows with the mechanically operated compaction hammer with a free fall of 18 in. (457.2 mm). Remove the base plate and collar, and reverse and reassemble the mold. Apply the same number of compaction blows to the face of the reversed specimen.

NOTE 4—It has been determined that 75 and 112 compaction blows applied to a 6-in. (152.4 mm) diameter specimen using the apparatus and procedure in this standard give densities equivalent to 50 and 75 compaction blows, respectively, applied to a 4-in. (101.6 mm) diameter specimen using Test Method D 1559.

5.5.3 Cool the compacted specimens and molds prior to

removal of the specimens from the molds to prevent distortion. After cooling, remove the base plate and place the sample extractor on that end of the specimen. Place the assembly with the extension collar up in the testing machine, apply pressure to the collar by means of the load transfer bar, and force the specimen into the extension collar. Lift the collar from the specimen. Carefully transfer the specimen to a smooth, flat surface and allow it to stand overnight at room temperature. Weigh, measure, and test the specimen.

NOTE 5—When more rapid cooling is desired, table fans may be used.

6. Procedure

6.1 Bring the specimens to the specified temperature by immersing in the water bath 45 to 60 min, or placing in the oven for 3 h. Maintain the bath or oven temperature at $140 \pm 1.8^\circ\text{F}$ ($60 \pm 1.0^\circ\text{C}$). Thoroughly clean the guide rods and the inside surfaces of the test heads prior to making the test, and lubricate the guide rods so that the upper test head slides freely over them. The testing-head temperature shall be maintained between 70 to 100°F (21.1 to 37.8°C) using a water bath when required. Remove the specimen from the water bath, oven, or air bath, and place in the lower segment of the breaking head. Place the upper segment of the breaking head on the specimen, and place the complete assembly in position on the testing machine. Place the flowmeter, where used, in position over one of the guide rods and adjust the flowmeter to zero while holding the sleeve firmly against the upper segment of the breaking head. Hold the flowmeter sleeve firmly against the upper segment of the breaking head while the test load is being applied.

6.2 Apply the load to the specimen by means of the constant rate of movement of the load jack or testing-machine head of 2 in. (50.8 mm)/min until the maximum load is reached and the load decreases as indicated by the dial. Record the maximum load noted on the testing machine or converted from the maximum micrometer dial reading. Release the flowmeter sleeve or note the micrometer dial reading, where used, the instant the maximum load begins to decrease. Note and record the indicated flow value or equivalent units in hundredths of an inch (twenty-five hundredths of a millimetre) if a micrometer dial is used to measure the flow. The elapsed time for the test from removal of the test specimen from the water bath to the maximum load determination shall not exceed 30 s.

6.3 For core specimens, correct the load when thickness is other than 3.75 in. (95.2 mm) by using the proper multiplying factor from Table 1. This table has been developed after Table 1 of Test Method D 1559 basing the correlation ratio on the percent change in specimen volume from standard specimen volume. Ensure that the core specimens have smooth sides; otherwise point loading can occur, resulting in low stability values.

7. Report

7.1 Report the following information:

7.1.1 Type of sample tested (laboratory sample or pavement core specimen),

7.1.2 The height of each test specimen in inches (or millimetres),

7.1.3 Average maximum load in pounds-force (or newtons)

TABLE 1 Stability Correlations Ratios^A

Approximate Thickness of Specimen ^B		Volume of Specimen, cm ³	Correlation Ratio
in.	mm		
3½	88.9	1608 to 1626	1.12
3 ⁹ / ₁₆	90.5	1637 to 1665	1.09
3 ⁵ / ₈	92.1	1666 to 1694	1.06
3 ¹¹ / ₁₆	93.7	1695 to 1723	1.03
3 ³ / ₄	95.2	1724 to 1752	1.00
3 ¹³ / ₁₆	96.8	1753 to 1781	0.97
3 ⁷ / ₈	98.4	1782 to 1810	0.95
3 ¹⁵ / ₁₆	100.0	1811 to 1839	0.92
4	101.6	1840 to 1868	0.90

^A The measured stability of a specimen multiplied by the ratio for the thickness of the specimen equals the corrected stability for a 3¾-in. (95.2-mm) thick specimen.

^B Volume-thickness relationship is based on a specimen diameter of 6 in. (152.4 mm).

of three specimens, corrected when required,

7.1.4 Average flow value, in hundredths of an inch (twenty-five hundredths of a millimetre) of three specimens, and

7.1.5 Test temperature.

TABLE 2 Acceptability of Test Results for Stability and Flow

Test and Type Index	Coefficient of Variation (% of mean) ^A	Acceptable Range of Two Test Results (% of mean) ^A
Single-operator precision:		
Stability, pounds-force	12.3	34.8
Flow, hundredth of an inch	16.7	47.2
Multilaboratory precision:		
Stability, pounds-force	15.3	43.3
Flow, hundredth of an inch	23.7	67.0

^A These numbers represent, respectively, the (1s %) and (d2s %) limits as described in Practice C 670.

8. Precision and Bias ⁵

8.1 Criteria for judging the acceptability of stability and flow values obtained by this test method are given in Table 2 (Note 6).

NOTE 6—These precision statements are based on 1 asphalt mixture, 3 replicates, and 12 laboratories. A gradation with 1½ in. (37.5 mm) maximum size stone was used. The average stability value was 5878 pounds-force and the average flow value was 18.6 units.

8.2 This test method has no bias because the values determined can be defined only in terms of the test method.

⁵ A copy of the research report used to develop the precision statement is available from ASTM headquarters. Request RR: D04–1014.

The American Society for Testing and Materials takes no position respecting the validity of any patent rights asserted in connection with any item mentioned in this standard. Users of this standard are expressly advised that determination of the validity of any such patent rights, and the risk of infringement of such rights, are entirely their own responsibility.

This standard is subject to revision at any time by the responsible technical committee and must be reviewed every five years and if not revised, either reapproved or withdrawn. Your comments are invited either for revision of this standard or for additional standards and should be addressed to ASTM Headquarters. Your comments will receive careful consideration at a meeting of the responsible technical committee, which you may attend. If you feel that your comments have not received a fair hearing you should make your views known to the ASTM Committee on Standards, at the address shown below.

This standard is copyrighted by ASTM, 100 Barr Harbor Drive, PO Box C700, West Conshohocken, PA 19428-2959, United States. Individual reprints (single or multiple copies) of this standard may be obtained by contacting ASTM at the above address or at 610-832-9585 (phone), 610-832-9555 (fax), or service@astm.org (e-mail); or through the ASTM website (www.astm.org).