



Standard Test Method for Minimum Autoignition Temperature of Dust Clouds¹

This standard is issued under the fixed designation E 1491; the number immediately following the designation indicates the year of original adoption or, in the case of revision, the year of last revision. A number in parentheses indicates the year of last reapproval. A superscript epsilon (ϵ) indicates an editorial change since the last revision or reapproval.

INTRODUCTION

This test method covers the determination of the minimum temperature at which a dust cloud will autoignite. The dust cloud is exposed to air heated to various temperatures in a furnace. Ignition of the cloud is indicated by visual observation of the flame. The chemical nature of the dust as well as its concentration, particle size, moisture, and surface area affects the results.

1. Scope

1.1 This test method covers the minimum temperature at which a given dust cloud will autoignite when exposed to air heated in a furnace at local atmospheric pressure.

1.2 Data obtained from this test method provide a relative measure of dust cloud autoignition temperatures.

1.3 This test method should be used to measure and describe the properties of materials, products, or assemblies in response to heat and flame under controlled laboratory conditions and should not be used to describe or appraise the fire hazard or fire risk of materials, products, or assemblies under actual fire conditions. However, results of this test method may be used as elements of a fire risk assessment which takes into account all of the factors which are pertinent to an assessment of the fire hazard of a particular end use.

1.4 *This standard does not purport to address all of the safety concerns, if any, associated with its use. It is the responsibility of the user of this standard to establish appropriate safety and health practices and determine the applicability of regulatory limitations prior to use.*

2. Referenced Documents

2.1 ASTM Standards:

D 3173 Test Method for Moisture in the Analysis Sample of Coal and Coke²

D 3175 Test Method for Volatile Matter in the Analysis Sample of Coal and Coke²

¹ This test method is under the jurisdiction of ASTM Committee E27 on Hazard Potential of Chemicals and is the direct responsibility of Subcommittee E27.05 on Explosibility and Ignitability of Dust Clouds.

Current edition approved Sept. 10, 1997. Published November 1997. Originally published as E 1491 – 91. Last previous edition E 1491 – 92.

² *Annual Book of ASTM Standards*, Vol 05.05.

E 659 Test Method for Autoignition Temperature of Liquid Chemicals³

E 1226 Test Method for Pressure and Rate of Pressure Rise for Combustible Dusts³

3. Terminology

3.1 Definitions of Terms Specific to This Standard:

3.1.1 *dust concentration*—the mass of dust divided by the internal volume of the test chamber.

3.1.2 *minimum autoignition temperature (MAIT)*—the minimum temperature at which a dust cloud will self ignite under the specified conditions of test.

4. Summary of Test Method

4.1 The temperature of the furnace or oven is set at a predetermined value.

4.2 Dust is blown into the heated furnace, which is at ambient pressure.

4.3 Ignition is determined by visual observation of the flame exiting the furnace.

5. Significance and Use

5.1 This test method provides a procedure for performing laboratory tests to determine the minimum autoignition temperature (MAIT) of a dust cloud.

5.2 The test data developed from this test method can be used to limit the temperature to which a dust cloud is exposed so as to prevent ignition of the cloud. Because of the short duration of the test, the data obtained are most applicable to industrial equipment where dust is present as a cloud for a short time. Because of the small scale of the test and the possible

³ *Annual Book of ASTM Standards*, Vol 14.02.

variation of the MAIT value with scale, the data obtained by this test method may not be directly applicable to all industrial conditions.

5.3 The MAIT data can also be used in conjunction with minimum spark ignition data to evaluate the hazards of grinding and impact sparks in the presence of dust clouds (1 and 2).⁴

5.4 The test values obtained are specific to the sample tested, the method used, and the test equipment utilized. The test values are not to be considered intrinsic material constants, but may be used as a relative measure of the temperature at which a dust cloud self ignites.

5.5 The test data are for cloud ignition. Dust in the form of a layer may ignite at significantly lower temperatures than the same dust in the form of a cloud (3).

6. Interferences

6.1 Unburned dust from a previous test may affect results. If there is a question, the furnace should be heated to its maximum temperature to clean it before future tests are made.

6.2 The material of construction of this test method may have catalytic effects on the ignition and should be considered during testing.

7. Apparatus

7.1 The equipment consists of a heated chamber closed with a frangible diaphragm, or flap vent, or a hole open to the atmosphere.

7.2 The chamber is insulated and provided with a thermostatically controlled electric heater. A thermocouple measures the set temperature of the chamber.

7.3 A dust dispersion system generates a fairly uniform dust cloud within the chamber. There should be a minimal amount of dust remaining in the disperser after the test.

7.4 A thermocouple (1 mil or 25 μm) and a recording system having a fast enough response may be used to measure the temperature rise during ignition of the dust cloud in the chamber.

7.5 Examples of chambers and specific procedures that have been found suitable are listed in chronological order in Appendix X1-Appendix X4.

8. Hazards

8.1 Safety Precautions:

8.1.1 Prior to handling a dust, its toxicity and the toxicity of its combustion products must be considered. This information can usually be obtained from the manufacturer. Consideration will have to be given to ventilation, use of hoods, personal protective gear, and procedures.

8.1.2 Explosive, highly reactive, or easily decomposed materials should not be tested unless they have been characterized by prior testing. Procedures such as the use of barricades, hoods, and personal protective equipment should be used as judgment indicates.

8.1.3 Electrical systems must be grounded.

9. Sampling

9.1 It is not practical to specify a single method of sampling dust for test purposes because the character of the material and its available form affect selection of the sampling procedure. Generally accepted sampling procedures should be used as described in STP 447A.⁵

9.2 Tests may be run on an as-received sample. However, due to the possible accumulation of fines at some location in a processing system, it is recommended that the test sample be at least 95 % minus 200 mesh (75 μm).

9.3 To achieve this particle fineness (95 % minus 200 mesh), grind, pulverize, or sieve the sample.

NOTE 1—The operator should consider the thermal stability and the friction and impact sensitivity of the dust during any grinding or pulverizing. In sieving the material, the operator must verify that there is no selective separation of components in a dust that is not a pure substance.

NOTE 2—It may be desirable in some cases to conduct dust autoignition tests on a material as sampled from a process because dust streams may contain a wide range of particle sizes or have a well-defined specific moisture content, materials consisting of a mixture of chemicals may be selectively separated on sieves, and certain fibrous materials may not pass through a relatively coarse screen. When a material is tested in the as-received state, it should be recognized that the test results may not represent the lowest cloud autoignition temperature possible. Any process change resulting in a higher fraction of fines than normal or drier product than normal may decrease the autoignition temperature.

9.4 The moisture content of the test sample should not exceed 10 % in order to avoid noticeable influence on test results of a given dust.

NOTE 3—There is no single method for determining the moisture content or for drying a sample. ASTM lists many methods for moisture determination in the *Annual Book of ASTM Standards*. Sample drying is equally complex due to the presence of volatiles, lack of or varying porosity (see Test Methods D 3173 and D 3175), and sensitivity of the sample to heat. Therefore, each must be dried in a manner that will not modify or destroy the integrity of the sample. Hygroscopic materials must be desiccated.

10. Calibration and Standardization

10.1 Any new test vessel design other than those listed in the appendixes must be standardized using dust samples whose MAIT values are known. A minimum of three dust samples over a wide range of MAIT values is required. For temperatures below 600°C, the MAIT value for each dust measured in a furnace must agree to within $\pm 60^\circ\text{C}$ of the average MAIT value for that dust as measured in the four furnaces in Appendix X1-Appendix X4.

10.2 Representative MAIT data for six dusts are listed in degrees Celsius in Table 1. These data are only intended to indicate the variability among furnaces. The anthracite coal has $\sim 85\%$ minus 200 mesh and a mass median diameter of $\sim 40\ \mu\text{m}$. The anthraquinone ($\text{C}_{14}\text{H}_8\text{O}_2$) has $\sim 73\%$ minus 200 mesh and a mass median diameter of $\sim 56\ \mu\text{m}$. The Pocahontas (Poc.) seam bituminous coal has $\sim 70\%$ minus 200 mesh, a mass median diameter of $\sim 56\ \mu\text{m}$, and 18 % volatility. The

⁴ The boldface numbers in parentheses refer to the list of references at the end of this test method.

⁵ STP 447A is available from ASTM Headquarters, 1916 Race St., Philadelphia, PA 19103.

TABLE 1 Examples of MAIT Data, °C

	G-G Furnace	BAM Oven	1.2-L Furnace	6.8-L Furnace
Anthracite coal	>900	>600	740	730
Anthraquinone	670	>600	620	680
Pocahontas (Poc) bituminous coal	640	580	610	600
Pittsburgh (Pgh) bituminous coal	600	570	540	530
Lycopodium	460	410	440	380
Sulfur	260	240	290	260

Pittsburgh (Pgh.) seam bituminous coal has ~80 % minus 200 mesh, a mass median diameter of ~45 µm, and 36 % volatility. The lycopodium is the reticulate form, *Lycopodium clavatum*. It is a natural plant spore having a narrow size distribution with 100 % minus 200 mesh and mass median diameter of ~28 µm. The sulfur has ~81 % minus 200 mesh and a mass median diameter of ~38 µm.

10.2.1 These data are from the four furnaces listed in the appendixes—the 0.27-L Godbert-Greenwald (G-G) Furnace, the 0.35-L BAM Oven, the 1.2-L Bureau of Mines Furnace, and the 6.8-L Bureau of Mines Furnace. The BAM oven is limited to a maximum test temperature of 600°C. The G-G Furnace generally yields somewhat higher MAIT data than the other three. The greatest deviation in MAIT values occurs at the highest temperatures, as shown by the anthracite coal data in the table. However, the lower MAIT values (where agreement is better) are of greater practical importance.

10.3 In addition to the initial calibration of a furnace, retest at least one standard dust periodically to verify that the furnace test conditions have not changed.

11. Procedure

11.1 These general procedures are applicable for all suitable furnaces. The detailed procedures specific to each furnace are listed in the corresponding appendix.

11.2 Inspect equipment to be sure it is thoroughly clean and in good operational condition.

11.3 Set the temperature of the furnace or oven at the predetermined value.

NOTE 4—For most furnaces, it is generally desirable to approach the MAIT from below to avoid a violent dust explosion in the chamber. However, the recommended procedure for the BAM oven is to approach the MAIT from above (see Appendix X2).

11.4 Place a weighed amount of dust in the disperser. The recommended initial test concentration for most dusts is from 300 to 1000 g/m³. If data from Test Method E 1226 exist for the dust, the initial test could be made at the concentration at which the maximum pressure, P_{max} , and the maximum normalized rate of pressure increase, K_{st} , were found.

11.5 Disperse the dust and observe whether or not flame exits the furnace.

NOTE 5—It is useful to darken the room to make it easier to observe the flame. Some flames, such as the blue flame of sulfur, are difficult to see.

11.6 If no ignition occurs, increase the temperature 50 to 100°C and test the dust again at the same concentration.

11.7 After ignition has been achieved, lower the test temperature in 25°C increments to determine the lowest temperature at which ignition occurs and the highest temperature at

which ignition does not occur for this dust concentration. Ignition is defined as flame exiting from the chamber.

11.8 At the highest temperature at which ignition is not observed, vary the dust concentration. If the dust ignites at any concentration at this temperature, lower the test temperature and continue the testing. At least five tests over a range of concentrations must be run at the highest temperature at which ignition is not observed.

11.9 At the temperature at which ignition is observed, vary the dust concentration to determine the range over which ignition occurs. In order to assure the repeatability of the data, observe at least three ignitions over a range of concentrations at the lowest temperature at which ignition occurs.

11.10 The reason for varying the concentration in 11.8 and 11.9 is to ensure that the autoignition temperature is measured at the most easily ignited concentration. However, the autoignition temperature is usually relatively independent of concentration, as shown in Fig. 1 and Fig. 2.

11.11 The final determination of the MAIT must be made by varying the temperature in increments of 25°C or smaller.

11.12 Fig. 1 is an example of a typical test pattern of temperatures and concentrations. Fig. 2 is a more detailed series of tests to show the reproducibility of the data and the range of concentrations over which ignition occurs.

12. Calculation

12.1 The minimum autoignition temperature (MAIT) of the dust cloud is the average of the lowest temperature at which ignition was reproducibly observed and the highest temperature at which ignition was not observed at any concentration. If there is an intermediate temperature at which ignition is observed for about half the tests, report this as the MAIT. Round the reported MAIT value to the nearest 10°C. As an example, the MAIT for polyethylene dust in Fig. 1 would be 375°C, or rounded to 370°C for the report. For the coal dust data in Fig. 2, the MAIT would be 540°C.

13. Report

13.1 Report the following information:

13.1.1 Complete identification of the material tested; including type of dust, source, code numbers, forms, and previous history,

13.1.2 Particle size distribution of the sample as received and as tested,

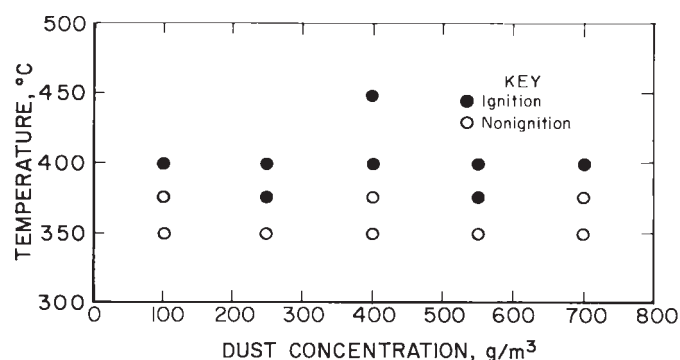

FIG. 1 Typical Data for the Measurement of the Minimum Autoignition Temperature of a Polyethylene Dust

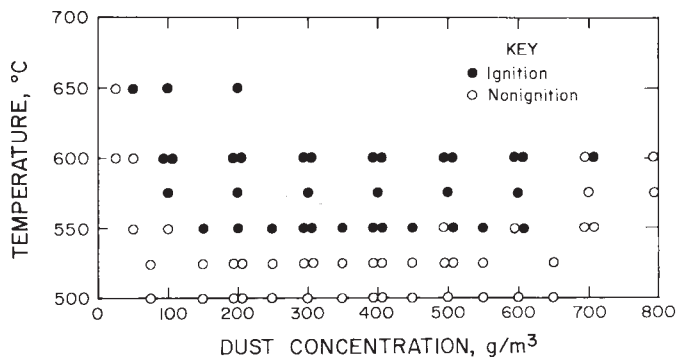

FIG. 2 Typical Detailed Data for the Minimum Autoignition Temperature of a Coal Dust

13.1.3 Moisture or volatile content, or both, of the as-received and as-tested material, if applicable,

13.1.4 Minimum autoignition temperature (MAIT) of the dust (usually rounded to the nearest 10°C) and the temperature increments used during the MAIT measurement,

13.1.5 The concentration range at which the MAIT was measured,

13.1.6 Name of test furnace or oven used, and

13.1.7 Any deviation from the normal test procedures.

14. Precision and Bias

14.1 *Precision*—Measurement of the MAIT of a dust in any one of the furnaces in the appendixes should be repeatable to within $\pm 30^\circ\text{C}$. For temperatures below 600°C , the MAIT value for each dust measured in a furnace should be within $\pm 60^\circ\text{C}$ of the average MAIT value for that dust as measured in the four furnaces in Appendix X1-Appendix X4.

14.2 *Bias*—The MAIT data determined in the Godbert-Greenwald Furnace (Appendix X1) are generally somewhat higher than the data from the other three furnaces (see Table 1).

15. Keywords

15.1 autoignition temperature; dust cloud; ignition

APPENDIXES

(Nonmandatory Information)

X1. GODBERT-GREENWALD FURNACE

X1.1 General Description

X1.1.1 Fig. X1.1 is a general schematic of the furnace. Further details may be found in Refs (4) and (5).

X1.1.2 The test chamber consists of a vertical ceramic tube, 3.9 cm in diameter and 23 cm high. Its volume is 0.27 L.

X1.1.3 Glass tubing connects the test chamber with the brass dust dispersion chamber.

X1.1.4 The outside of the test chamber is wound with 6.4 m of 18-gage nichrome heater wire. The windings are placed closer together at the top and bottom of the furnace than in the middle to obtain a more even temperature throughout. The windings are surrounded with insulation.

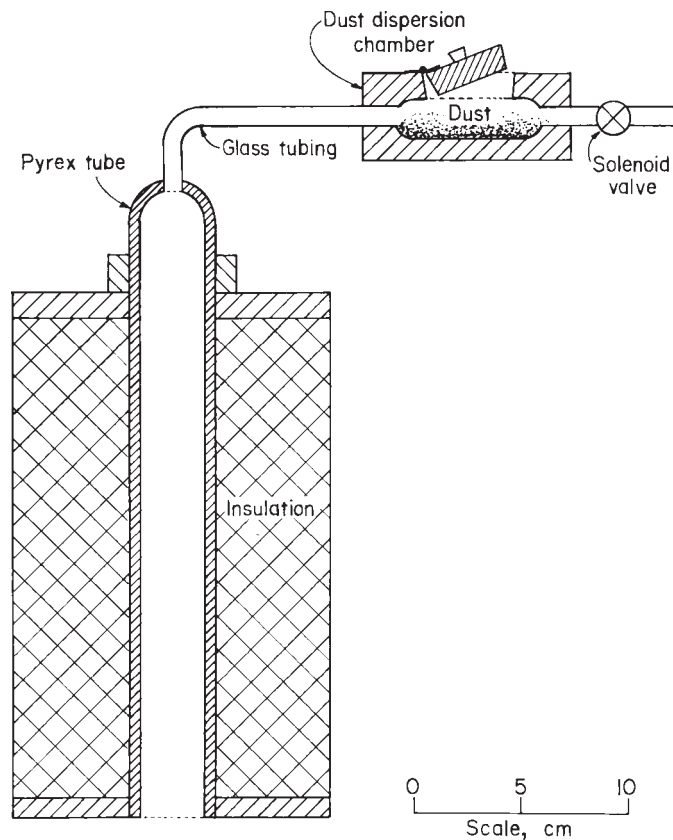

FIG. X1.1 Vertical Cross Section of the Godbert-Greenwald Furnace

X1.2 Test Procedure

X1.2.1 Set the furnace to the predetermined test temperature.

X1.2.2 Place the preweighed dust sample into the dispersion chamber.

X1.2.3 Activate the solenoid valve to disperse the dust into the furnace.

X1.2.4 Ignition is defined as the observation of flame exiting from the bottom of the furnace.

X2. BAM OVEN

X2.1 General Description

X2.1.1 Fig. X2.1 and Fig. X2.2 are schematics of the 0.35-L oven designed at the Bundesanstalt für Materialforschung und -prüfung (BAM) in Berlin, Germany.⁶ Further details of the BAM oven may be found in Ref (6).

X2.1.2 The maximum operating temperature of the oven is 600°C. It is limited due to the heat losses relative to the 1500-W input electrical energy to the heating coils. This maximum temperature is, however, sufficient for most practical applications of the MAIT data.

X2.1.3 The test chamber consists of a horizontal, heat-resistant steel container with a hinged flap at the rear (see Fig. X2.1).

X2.2 Test Procedure

X2.2.1 An initial estimate of the MAIT may be found by heating the oven to 600°C and then switching off the power and

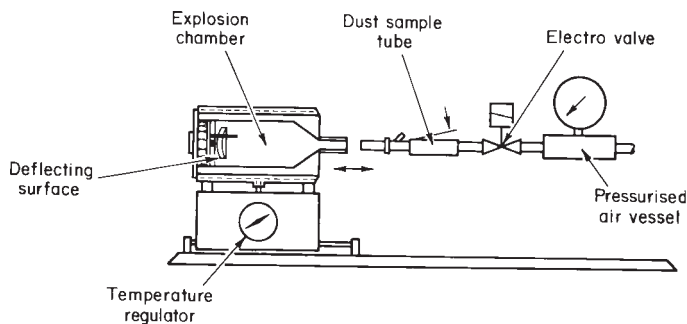

FIG. X2.2 Automated Version of the BAM Oven

allowing the temperature to fall. At intervals of $\sim 50^\circ\text{C}$ as the temperature falls, disperse the premeasured dust into the furnace with a blast of air. Observe the presence or absence of flame exiting the rear of the oven. A small strategically placed mirror is helpful in observing the flame.

X2.2.2 After obtaining an estimate of the MAIT, determine the exact value by a series of tests at various dust concentrations and at temperatures near the estimate. For this series, the oven must be allowed to stabilize at the set temperature before each test. Begin by raising the temperature to the lowest value for which flame was observed. Continue by decreasing the test temperature in 10°C increments until flame is no longer observed.

X2.2.2.1 For each test, set the oven to the predetermined test temperature.

X2.2.2.2 Place the premeasured dust in the dust sample tube. The initial test concentration usually corresponds to a measured volume of $\sim 1\text{ cm}^3$.

X2.2.2.3 Insert the dust sample tube into the furnace and disperse the dust with a blast of air.

X2.2.2.4 Ignition of the dust is defined as the observation of flame exiting the flap at the rear of the oven.

X2.2.2.5 At the highest temperature for which no flame is observed, test at least three dust concentrations. These usually correspond to volumes of 0.5, 1, and 2 cm^3 .

X2.2.3 The test report lists the MAIT as the lowest temperature at which any positive result (flame) was observed.

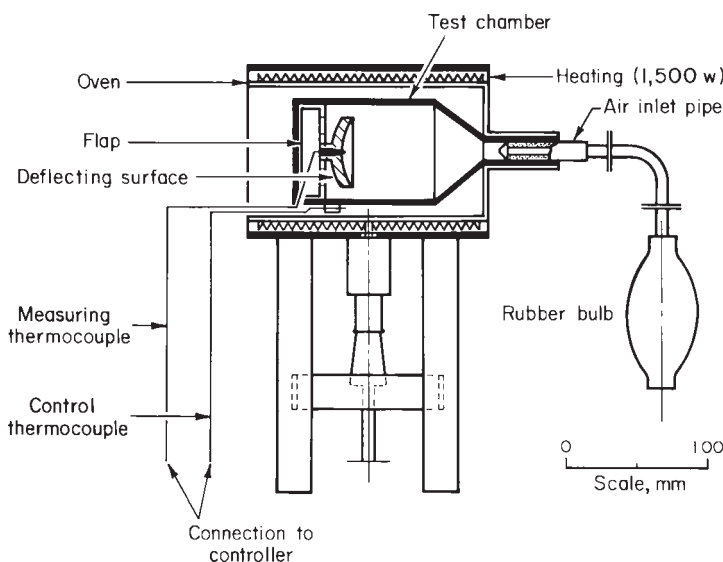

FIG. X2.1 Manually Operated Version of the BAM Oven

⁶ Available from Adolph Kühner AG, Dinkelbergstrasse 1, CH-4127, Birsfelden, Switzerland.

X3. BUREAU OF MINES 1.2-L FURNACE

X3.1 General Description

X3.1.1 Fig. X3.1 and Fig. X3.2 are schematics of the 1.2-L furnace.⁷ Further details on the furnace and its operation may be found in Refs (7) and (8).

X3.1.2 The 1.2-L test chamber is made of magnesium aluminum silicate ceramic. Inside dimensions are 10-cm diameter and 33 cm high. It is wrapped with a 9.7-m length of 18-gage nichrome heater wire. The chamber and heater wire are covered with a layer of ceramic braided cloth. The outer shell consists of a cylinder of sheet metal (30-cm diameter and 30 cm high) with a transite top and bottom. This shell is filled with loose ceramic insulation.

X3.1.3 A 12.5-mil (320- μ m) Chromel-Alumel thermocouple located at the inside wall of the furnace is used to control the chamber temperature. Another access hole allows a

⁷ Design drawings available from the Pittsburgh Research Center, Bureau of Mines, U.S. Department of the Interior, P.O. Box 18070, Pittsburgh, PA 15236.

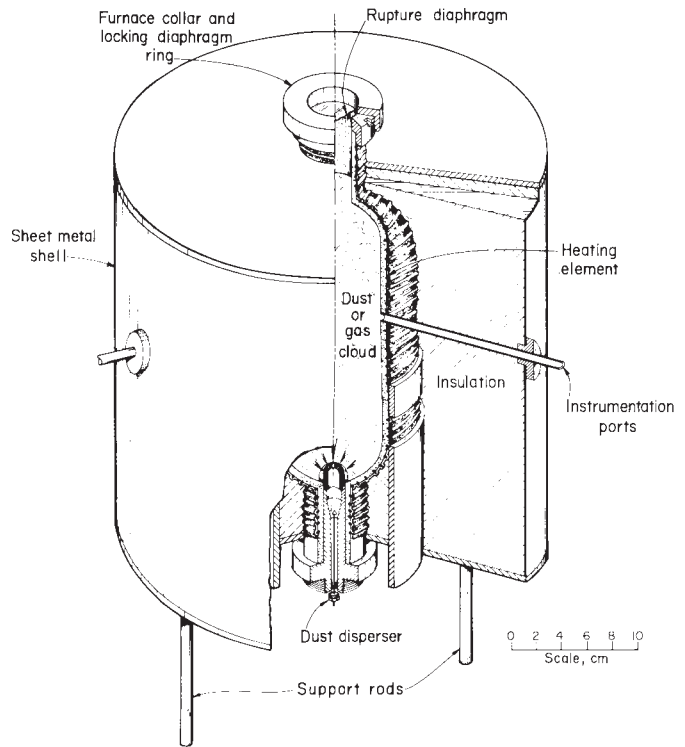

FIG. X3.2 Perspective Drawing of the Bureau of Mines 1.2-L Furnace

1-mil (25- μ m) platinum-rhodium thermocouple to be positioned near the center of the furnace to monitor the rapid increase in temperature as the dust cloud ignites. The temperature profile within the furnace is shown in Fig. X3.3.

X3.1.4 The dust dispersion receptacle is machined of brass and has a removable screw top to allow the dust to be inserted. The receptacle is connected by tubing to a 60-cm³ air dispersion tank.

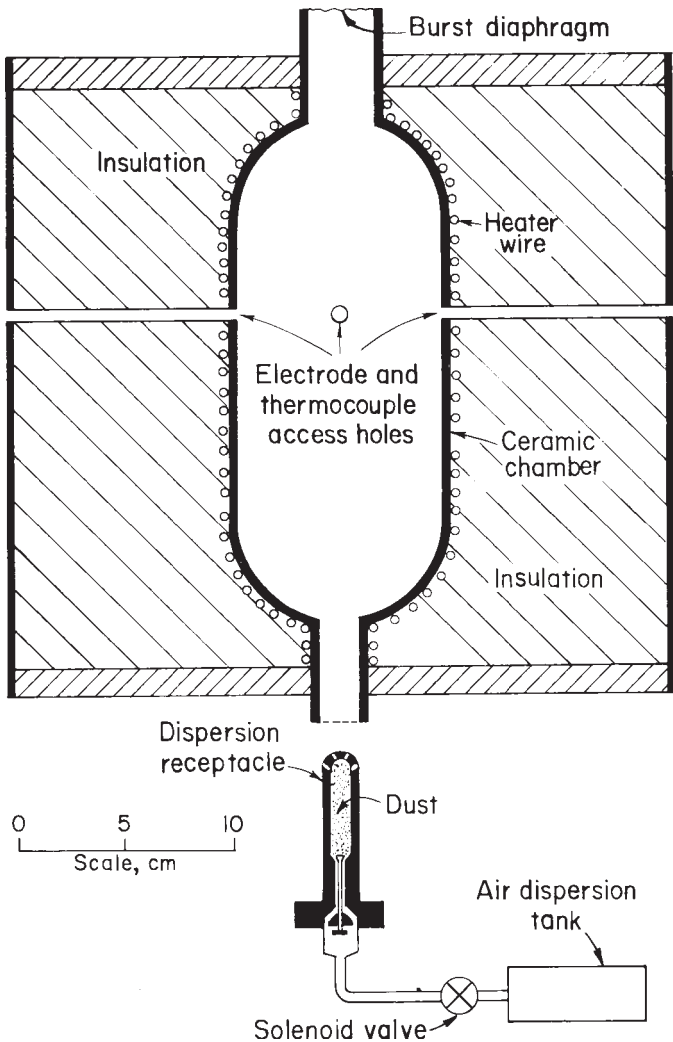

FIG. X3.1 Vertical Cross Section of the Bureau of Mines 1.2-L Furnace

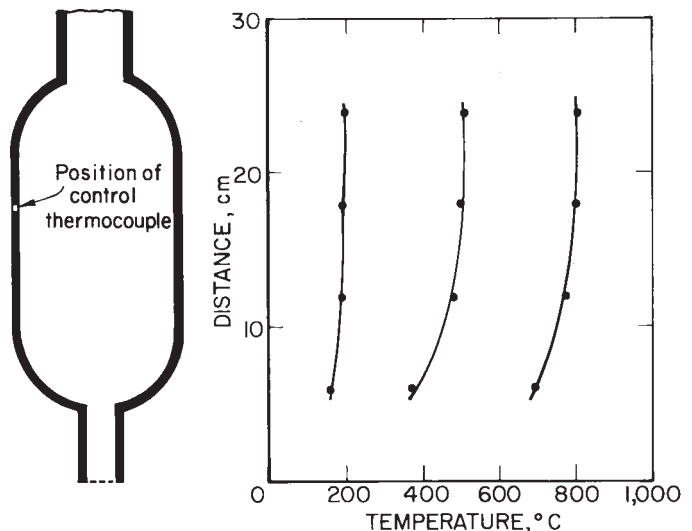

FIG. X3.3 Temperature Profile in the Bureau of Mines 1.2-L Furnace

X3.1.5 The maximum operating temperature is 1000°C.

X3.2 Test Procedure

X3.2.1 Place a frangible diaphragm made of glass microfiber in the holder at the top of the chamber and set the furnace to the predetermined test temperature.

X3.2.2 After reaching the set temperature, place the preweighed dust sample in the dispersion receptacle and screw on the top.

X3.2.3 Then manually insert the dispersion receptacle into the furnace and actuate the dispersion air solenoid valve. The blast of air from the dispersion tank disperses the dust through the nine small holes in the top of the dispersion receptacle.

X3.2.4 Ignition of the dust cloud is defined as the rupture of the diaphragm and the observation of flame exiting from the top of the chamber within a time period of 3 s. The 1-mil thermocouple may also be used to monitor the rapid temperature rise of the flame within the furnace. However, observation of flame by the thermocouple within the furnace is not sufficient, by itself, to constitute an ignition.

X3.2.5 After the test, remove the holder and remainder of the diaphragm from the top of the chamber and use a blast of air from the bottom to remove any residual dust from the chamber.

X3.2.6 After several tests, it may be advisable to heat the furnace to a temperature of 900°C to burn off any dust accumulation on the walls.

X4. BUREAU OF MINES 6.8-L FURNACE

X4.1 General Description

X4.1.1 Fig. X4.1 and Fig. X4.2 are schematics of the 6.8-L

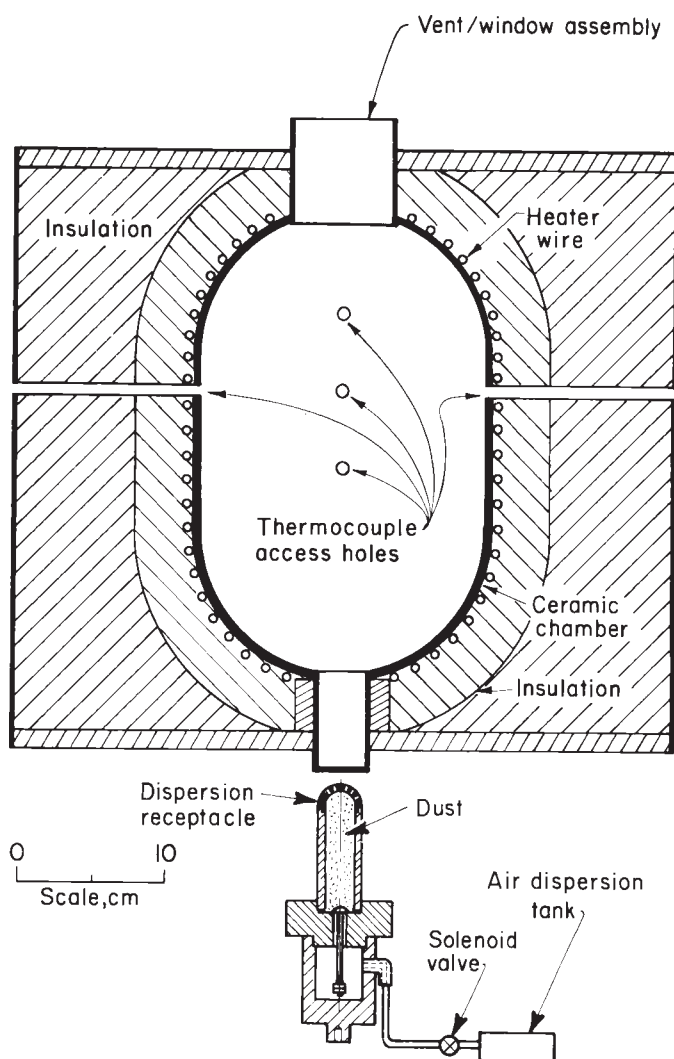

FIG. X4.1 Vertical Cross Section of the Bureau of Mines 6.8-L Furnace

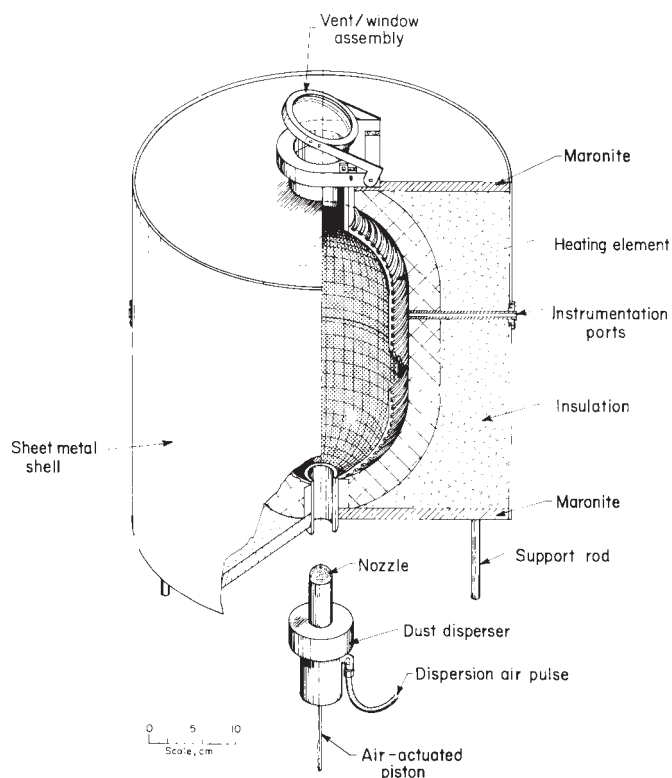

FIG. X4.2 Perspective Drawing of the Bureau of Mines 6.8-L Furnace

furnace.⁷ Further details on the furnace and its operation may be found in Ref (9).

X4.1.2 The 6.8-L test chamber is made of magnesium aluminum silicate ceramic. Inside dimensions are 19-cm diameter and 44 cm high. It is wrapped with a 24-m length of 12-gage nichrome heater wire. The chamber and heater wire are covered with a layer of ceramic braided cloth. The outer shell consists of a cylinder of sheet metal (45-cm diameter and 40 cm high) with a maronite top and bottom. This shell is filled with ceramic blanket insulation.

X4.1.3 A 12.5-mil (320- μ m) Chromel-Alumel thermocouple located near the center axis of the furnace is used to

control the chamber temperature. Another access hole allows a 1-mil (25- μm) platinum-rhodium thermocouple to be positioned at the center axis of the furnace to monitor the rapid increase in temperature as the dust cloud ignites. The temperature profile within the furnace is shown in Fig. X4.3.

X4.1.4 The dust dispersion receptacle is machined of brass and has a removable screw top to allow the dust to be inserted. Tubing connects the receptacle to a 150-cm³ air dispersion tank. The dispersion receptacle is automatically inserted into the furnace by an air-actuated piston.

X4.1.5 At the top of the furnace is a quartz window in a hinged inconel housing. This vent/window relieves the pressure of the explosion.

X4.1.6 The maximum operating temperature is 1000°C.

X4.2 Test Procedure

X4.2.1 Set the furnace to the predetermined test temperature.

X4.2.2 After the furnace has reached the set temperature, place the preweighed dust sample in the dispersion receptacle and screw on the top.

X4.2.3 Then activate the automatic timing sequence. Insert the dispersion receptacle into the furnace by the piston, and then open the dispersion air solenoid valve. The blast of air from the dispersion tank disperses the dust through the 34 small holes in the top of the dispersion receptacle. After 6 s, the dispersion receptacle is automatically retracted from the furnace.

X4.2.4 Ignition of the dust cloud is defined as the opening of the vent/window and the observation of flame exiting from the top of the chamber within a time period of 6 s. The 1-mil thermocouple may also be used to monitor the rapid temperature rise of the flame within the furnace. However, observation of flame within the furnace is not sufficient, by itself, to constitute an ignition.

X4.2.5 After the test, use a blast of air to remove any residual dust from the chamber.

X4.2.6 After several tests, it may be advisable to heat the furnace to a temperature of 900°C to burn off any dust accumulation on the walls.

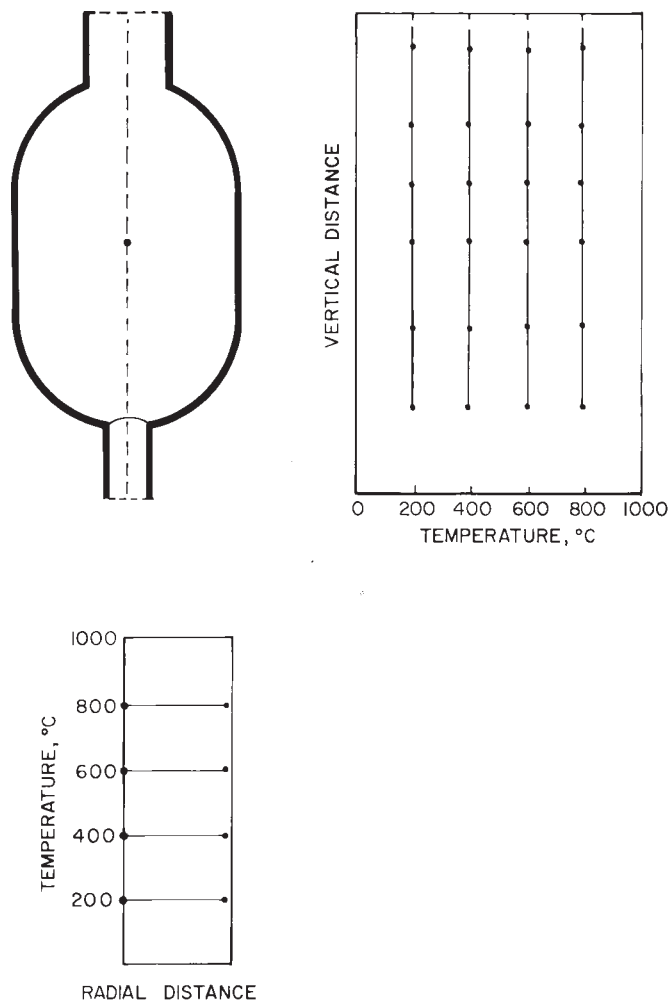



FIG. X4.3 Temperature Profiles in the Bureau of Mines 6.8-L Furnace

REFERENCES

- (1) Bartknecht, W., "Preventive and Design Measures for Protection Against Dust Explosions," *Industrial Dust Explosions, ASTM STP 958*, K. L. Cashdollar and M. Hertzberg, Eds., ASTM, Philadelphia, 1987, pp. 158–190.
- (2) Bartknecht, W., *Dust Explosions: Course, Prevention, Protection*, Springer-Verlag, New York, NY 1989.
- (3) *Fire Protection Handbook*, 14th ed., NFPA, Boston, 1976, pp. 3-106–3-113.
- (4) Godbert, A. L., and Greenwald, H. P., "Laboratory Studies of the Inflammability of Coal Dust," *Bulletin 389*, U.S. Bureau of Mines, 1935.
- (5) Dorsett, H. G., Jr., Jacobson, M., Nagy, J., and Williams, R. P., "Laboratory Equipment and Test Procedures for Evaluating Explosibility of Dusts," RI 5624, U.S. Bureau of Mines, 1960.
- (6) Hattwig, M., "Explosion Hazard Classification, Explosion Safety Parameters, and Relevant Measurement Techniques Applied in the Federal Republic of Germany," *Proceedings of the International Symposium on the Explosion Hazard Classification of Vapors, Gases, and Dusts*, NMAB-447, National Academy Press, Washington, DC, 1987, pp. 159–179.
- (7) Conti, R. S., Cashdollar, K. L., Hertzberg, M., and Liebman, I., "Thermal and Electrical Ignitability of Dust Clouds," RI 8798, U.S. Bureau of Mines, 1983, 40 pp.
- (8) Conti, R. S., and Hertzberg, M., "Thermal Autoignition Temperatures from the 1.2-L Furnace and Their Use in Evaluating the Explosion Potential of Dusts," *Industrial Dust Explosions, ASTM STP 958*, K. L. Cashdollar and M. Hertzberg, Eds., ASTM, Philadelphia, 1987, pp. 45–59.
- (9) Conti, R. S., Cashdollar, K. L., and Thomas, R. A., "Improved 6.8-L Furnace for Measuring the Autoignition Temperature of Dust Clouds," U.S. Bureau of Mines, RI 9467, 1993.

 **E 1491 – 97 (2002)**

ASTM International takes no position respecting the validity of any patent rights asserted in connection with any item mentioned in this standard. Users of this standard are expressly advised that determination of the validity of any such patent rights, and the risk of infringement of such rights, are entirely their own responsibility.

This standard is subject to revision at any time by the responsible technical committee and must be reviewed every five years and if not revised, either reapproved or withdrawn. Your comments are invited either for revision of this standard or for additional standards and should be addressed to ASTM International Headquarters. Your comments will receive careful consideration at a meeting of the responsible technical committee, which you may attend. If you feel that your comments have not received a fair hearing you should make your views known to the ASTM Committee on Standards, at the address shown below.

This standard is copyrighted by ASTM International, 100 Barr Harbor Drive, PO Box C700, West Conshohocken, PA 19428-2959, United States. Individual reprints (single or multiple copies) of this standard may be obtained by contacting ASTM at the above address or at 610-832-9585 (phone), 610-832-9555 (fax), or service@astm.org (e-mail); or through the ASTM website (www.astm.org).