



Standard Test Method for Fire Testing of Upholstered Furniture¹

This standard is issued under the fixed designation E 1537; the number immediately following the designation indicates the year of original adoption or, in the case of revision, the year of last revision. A number in parentheses indicates the year of last approval. A superscript epsilon (ϵ) indicates an editorial change since the last revision or reapproval.

1. Scope

1.1 This is a fire-test-response standard.

1.2 The purpose of this test method is to determine the burning behavior of upholstered furniture used in public occupancies by measuring specific fire-test responses when the specimen of furniture is subjected to a specified flaming ignition source under well-ventilated conditions.

1.3 Data are obtained describing the burning behavior from a specific ignition source until all burning has ceased, a period of 1 h has elapsed, or flashover appears inevitable.

1.4 This test method does not provide information on the fire performance of upholstered furniture in fire conditions other than those conditions specified. In particular, this test method does not apply to smoldering ignition by cigarettes. See X1.6 for further information.

1.5 The rate of heat release of the burning specimen is measured by an oxygen consumption method. See X1.6.4 for further information.

1.6 The production of light obscuring smoke is measured and the concentrations of certain toxic gas species in the combustion gases are determined. See X1.6.5 for further information.

1.7 The burning behavior is visually documented by photographic or video recordings, whenever possible.

1.8 The system of units to be used in referee decisions is the SI system of units, see Practice E 380 only. The units given in parentheses are for information only.

1.9 *This standard is used to measure and describe the response of materials, products, or assemblies to heat and flame under controlled conditions, but does not by itself incorporate all factors required for fire hazard or fire risk assessment of the materials, products or assemblies under actual fire conditions.*

1.10 *Fire testing of products and materials is inherently hazardous, and adequate safeguards for personnel and property shall be employed in conducting these tests. This test method may involve hazardous materials, operations, and equipment.*

1.11 *This standard does not purport to address all of the safety concerns, if any, associated with its use. It is the responsibility of the user of this standard to establish appropriate safety and health practices and determine the applicability of regulatory limitations prior to use.*

2. Referenced Documents

2.1 ASTM Standards:

D 123 Terminology Relating to Textiles²

E 84 Test Method for Surface Burning Characteristics of Building Materials³

E 176 Terminology of Fire Standards³

E 380 Practice for Use of the International System of Units (SI) (the Modernized Metric System)⁴

E 800 Guide for Measurement of Gases Present or Generated During Fires³

E 1354 Test Method for Heat and Visible Smoke Release Rates for Materials and Products Using an Oxygen Consumption Calorimeter³

2.2 ISO Standards:

ISO 3261 Fire Tests—Vocabulary⁵

ISO 4880 Burning Behaviour of Textiles and Textile Products—Vocabulary⁵

ISO 9705 Fire Tests—Full Scale Room Test for Surface Products⁵

2.3 UL Standard:

UL 1056 Fire Test of Upholstered Furniture⁶

2.4 CA Standard:

CA Technical Bulletin 133 Flammability Test Procedure for Seating Furniture for Use in Public Occupancies⁷

2.5 BSI Standard:

BS 5852: Part 2: Fire Tests for Furniture, Part 2. Methods of Test for the Ignitability of Upholstered Composites for Seating by Flame Sources⁸

2.6 Nordtest Standard:

² Annual Book of ASTM Standards, Vol 07.01.

³ Annual Book of ASTM Standards, Vol 04.07.

⁴ Annual Book of ASTM Standards, Vol 14.02.

⁵ Available from American National Standards Institute (ANSI), 25 W. 43rd St., 4th Floor, New York, NY 10036.

⁶ Available from Underwriters Laboratories (UL), Corporate Progress, 333 Pflugsten Rd., Northbrook, IL 60062.

⁷ Available from State of California, Department of Consumer Affairs, 3485 Orange Grove Avenue, North Highlands, CA 95660.

⁸ Available from British Standards Institution, 2 Park St., London W1A 2B5, UK.

¹ This test method is under the jurisdiction of ASTM Committee E05 on Fire Standards and is the direct responsibility of Subcommittee E05.15 on Furnishing and Contents.

Current edition approved Sept. 10, 2002. Published November 2002. Originally published as E 1537 – 93. Last previous edition E 1537 – 02.

Nordtest Method NT Fire 032 Upholstered Furniture: Burning Behavior—Full Scale Test⁹

3. Terminology

3.1 Definitions:

3.1.1 For definitions of terms used in this test method and associated with fire issues, refer to the terminology contained in Terminology E 176 and in ISO 3261.

3.1.2 For definitions of terms used in this test method and associated with textile issues refer to the terminology contained in Terminology D 123.

3.2 Definitions of Terms Specific to This Standard:

3.2.1 *product, n*—the upholstered furniture for which information is required.

3.2.2 *specimen, n*—manufactured item of the product, representative prototype of the product, or mock-up of the product.

3.2.2.1 *Discussion*—The mock-up shall be constructed as described in Annex A1.

3.2.3 *upholstered, adj*—covered with material (as fabric or padding) to provide a soft surface.

3.2.4 *upholstered seating furniture, n*—a unit of interior furnishing that (1) contains any surface that is covered, in whole or in part, with a fabric or other upholstery cover material, (2) contains upholstery material, and (3) is intended or promoted for sitting upon.

3.2.5 *upholstery cover material, n*—the outermost layer of fabric or related materials used to enclose the main support system, or upholstery materials, or both, used in the furniture unit.

3.2.6 *upholstery material, n*—the padding, stuffing, or filling material used in a furniture unit, which may be either loose or attached, enclosed by an upholstery cover material, or located between the upholstery cover material and support system, if present.

3.2.6.1 *Discussion*—This includes, but is not limited to, material, such as foams, cotton batting, polyester fiberfill, bonded cellulose, or down.

4. Summary of Test Method

4.1 This test method determines a number of fire-test-response characteristics from a full-scale specimen of upholstered furniture ignited with a propane gas burner. Measurements to be made include rate of heat and smoke release, total amount of heat and smoke released, rate and concentration of carbon oxides released, and rate and amount of mass of specimen lost. Other optional measurements are also described.

4.2 Three options are provided, in all of which the upholstered furniture specimen to be tested is placed on a weighing platform and measurements of heat release, smoke release, and combustion gas release are made in an exhaust duct.

4.3 In Options A and B the duct is located outside the doorway of a test room. In Option C the duct is located directly over the specimen.

4.4 Additional (optional) instrumentation placed in the test room is also described.

5. Significance and Use

5.1 This test method provides a means to measure a variety of fire-test-response characteristics resulting from burning a specimen of upholstered furniture. The upholstered furniture specimen is allowed to burn freely under well-ventilated conditions after ignition using a propane gas burner. The most important fire-test-response characteristic measured is the rate of heat release, which quantifies the intensity of the fire generated.

5.2 The rate of heat release is measured by the principle of oxygen consumption. The assumptions and limitations of oxygen depletion calorimetry are discussed in Annex A4, and in particular in A4.1.2.

5.3 Other fire-test-response characteristics are measured, namely smoke obscuration and combustion gas release, as they are also important in making decisions on fire safety.

5.4 The most important gaseous components of smoke are the carbon oxides, present in all fires. They are indicators of the toxicity of the atmosphere and of the completeness of combustion. Measurement of concentrations of carbon oxides are useful for two purposes: as part of fire hazard assessment calculations and to improve the accuracy of heat release measurements. Other toxic combustion gases, which are specific to certain materials, are less crucial for determining combustion completeness and are optional measures, but fire hazard assessment often requires their measurement.

5.5 The type of ignition chosen (a flaming source) is common in both accidental and intentional fires in public occupancies. This test method is thus applicable to upholstered furniture in public occupancies. Such facilities include, but are not limited to, jails, prisons, nursing care homes, health care facilities, public auditoriums, hotels, and motels.

5.6 It has been shown that if the gas burner is used at a flow rate of 13 L/min for 80 s (equivalent to 19.3 kW), as is the case in California Technical Bulletin (CA TB) 133, it approximates the ignition propensity of five crumpled sheets of newspaper located on the seating cushion.

5.7 This test method specifies both a particular flow rate of propane gas and a period of gas flow. If the ignition conditions are changed, the results would then deviate from the model selected for this test.

5.8 This test method is not applicable to ignition of upholstered furniture by cigarettes.

5.9 One of the following three test configurations is to be used in this test method:

5.9.1 **A**—A test room with the following dimensions: 3.66 by 2.44 by 2.44 m high.

5.9.2 **B**—A test room with the following dimensions: 3.66 by 3.05 by 2.44 m high.

5.9.3 **C**—An open calorimeter (or furniture calorimeter).

5.10 Measurements in the three test configurations listed in 5.9 have been shown to give similar results for heat release in the duct, for heat release rates lower than 600 kW (see X1.4) (**1**).¹⁰

⁹ Available from Nordtest, PO Box 22, SF-00341, Helsingfors, Finland.

¹⁰ The boldface numbers in parentheses refer to a list of references at the end of the text.

5.11 Measurements of temperatures, gas concentrations, and smoke obscuration in the room, which are optional in this test method, are dependent on room size.

5.12 This test method has been designed to give details for the means to build and operate equipment capable of running tests as required by CA TB 133. This test method is, however, more general than that technical bulletin.

6. Test Specimen

6.1 The test specimen consists of a full-size manufactured item of upholstered furniture, a representative prototype of the upholstered furniture, or a mock-up of the upholstered furniture, constructed in accordance with Annex A1.

6.2 When a full-scale upholstered furniture mock-up is used, the mock-up shall in all possible respects reflect the construction of the actual furniture that it is intended to represent.

7. Room Layout and Instrumentation

7.1 *Test Room Layout (Test Configuration A)*—The test room shall have dimensions of 2.44 m ± 25 mm by 3.66 m ± 25 mm by 2.44 m ± 25 mm high (8 by 12 by 8 ft high). The room shall have no openings other than a doorway opening 0.76 m ± 6.4 mm by 2.03 m ± 6.4 mm (30 by 80 in.), located as indicated in Fig. 1, and other small openings, as necessary to make test measurements. Construct the test room of wooden or metal studs, and line it with fire rated gypsum wallboard or calcium silicate wallboard. Position a hood, as described in Annex A2, outside of the room doorway, such that it collects all the combustion gases. There shall be no obstructions to the air supply to the test setup.

NOTE 1—Both Type X gypsum wallboard and calcium silicate wallboard with a thickness of at least 13 mm (0.5 in.) have been found acceptable. If the thickness of the wallboard is larger, it will not affect the results of this test.

7.2 *Test Room Layout (Test Configuration B)*—The test room shall have dimensions of 3.05 m ± 25 mm by 3.66 m ± 25 mm by 2.44 m ± 25 mm high (10 by 12 by 8 ft high). The room shall have no openings other than a doorway opening 0.97 m ± 6.4 mm by 2.06 m ± 6.4 mm (38 by 81 in.), located as indicated in Fig. 2, and other small openings, as necessary, to make test measurements. Construct the test room of wooden or metal studs, and line it with fire-rated gypsum wallboard or calcium silicate wallboard. Position a hood, as described in Annex A2, outside of the room doorway, such that it collects all the combustion gases. There shall be no obstructions to the air supply to the test set-up. (See Note 1.)

7.3 *Open Calorimeter Layout (Test Configuration C)*—The area surrounding the test specimen shall be sufficiently large that there are no heat radiation effects from the walls or any other nearby objects. The airflow to the test specimen shall be symmetrical from all sides.

7.4 *General Discussion of Room Layout*—Heat release measurements in the duct, made in Options A, B, and C have been shown to give similar results for heat release rates lower than 600 kW (see X1.4) (1).

7.5 *Other Test Room Furnishings*—The test room shall contain no furnishings except for the item to be tested.

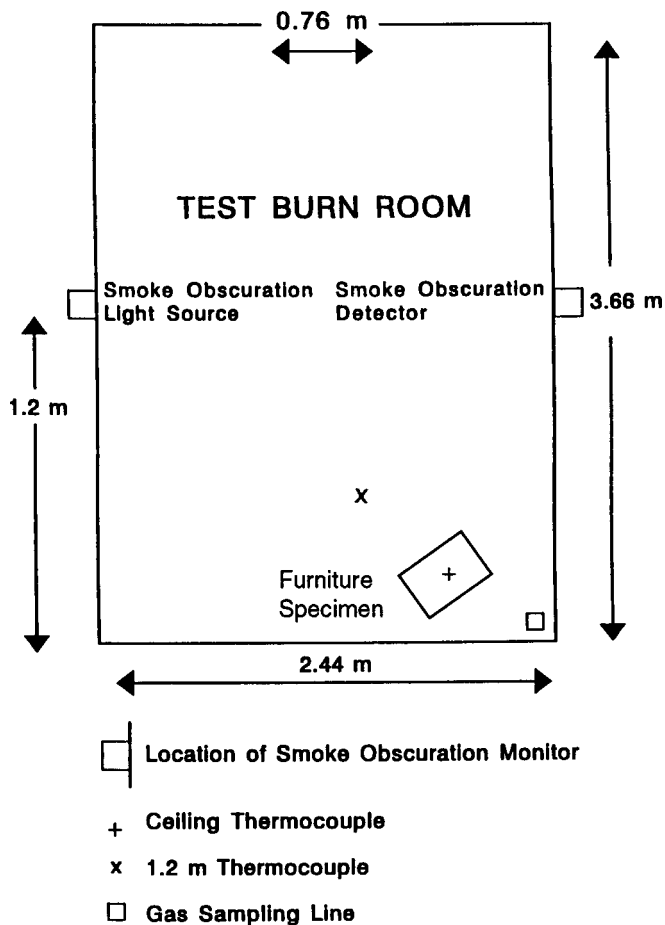

NOTE 1—See text for tolerances; room instrumentation is optional.
FIG. 1 Test Room Configuration for Option A for Items of Furniture Less Than 1 m Across

7.6 Test Room Instrumentation (Optional):

7.6.1 Location of optional test room instruments is described in Figs. 1-4.

7.6.2 Carry out optional room temperature measurements with chromel-alumel Type K thermocouples, shielded against high heat with insulation resisting up to 1200°C. Use a wire gage in the range of 24 to 30 AWG (0.51 to 0.36 mm) diameter, and mount the thermocouples in two test locations:

7.6.2.1 Over the geometric center of the igniter, 25 mm (1 in.) below the ceiling (ceiling thermocouple), and

7.6.2.2 At a distance of 0.91 m (3 ft) in front of the center of the igniter, away from the furniture specimen, and 1.22 m (4 ft) below the ceiling.

7.6.3 Carry out optional optical density of smoke measurements with a smoke obscuration monitor, placed at a height of 1.22 m (4 ft) above the floor level. A white light or laser photometer system similar to that described for the duct is also suitable (see 8.2.4 or Annex A3).

7.6.4 Carry out optional carbon monoxide concentration measurements with a gas sampling line located 165 mm (6.5 in.) below the ceiling and 165 mm (6.5 in.) from each wall of the corner where the specimen is placed.

7.7 Location of Specimen:

7.7.1 *Test Configurations A or B:*

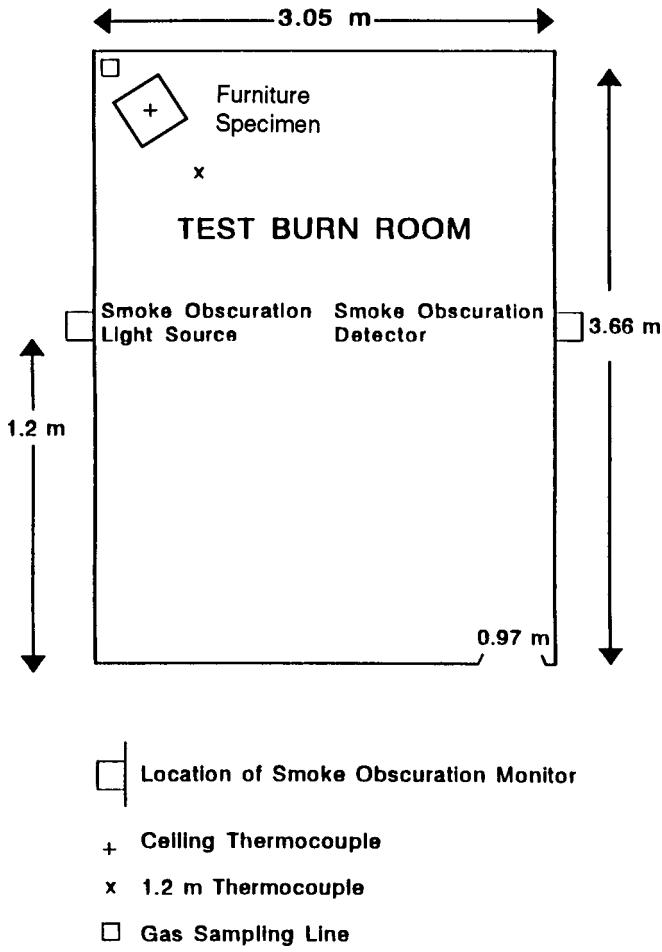

NOTE 1—See text for tolerances; room instrumentation is optional.
FIG. 2 Test Room Configuration for Option B for Items of Furniture Less Than 1 m Across

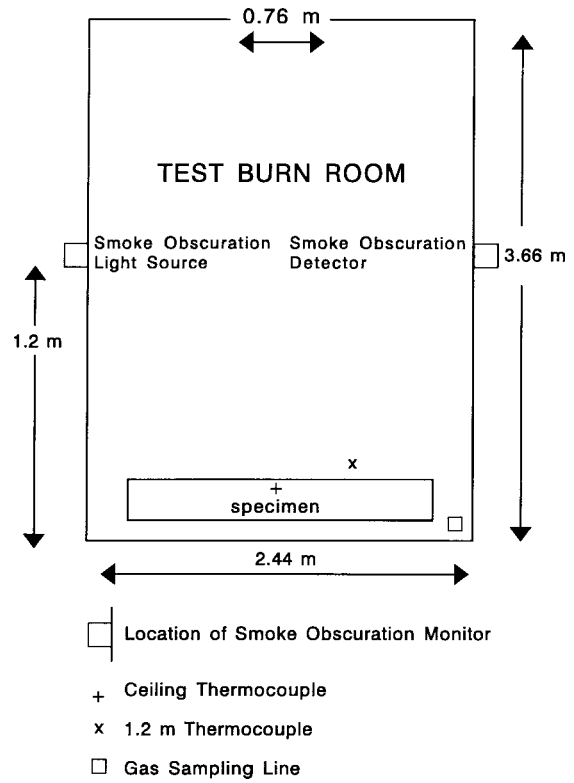

NOTE 1—See text for tolerances; room instrumentation is optional.
FIG. 3 Test Room Configuration for Option A for Items of Furniture Between 1 and 2.44 m Across

7.7.1.1 Position the furniture specimen on a weighing platform in a corner so that the furniture is at a distance of between 0.10 and 0.25 m (4 and 10 in.) from both walls.

7.7.1.2 The location for the furniture specimen is such that it faces the wall containing the doorway, with the preferred location at the greatest distance from the doorway.

7.7.1.3 If the furniture specimen is no more than 1.0 m (40 in.) in width, refer to Fig. 1 or 2 for the furniture specimen location. If the furniture specimen is more than 1.0 m (40 in.) in width, refer to Fig. 3 or Fig. 4.

7.7.1.4 These test configurations shall not be used to test furniture specimens that are more than 2.44 m (8 ft) in length.

7.7.2 *Test Configuration C:*

7.7.2.1 Position the furniture specimen on a weighing platform underneath the hood.

7.7.2.2 This test method, in Test Configuration C, is suitable for furniture specimens more than 2.44 m (8 ft) in length only if the hood is large enough to collect all the smoke generated.

7.8 *Ignition Source:*

7.8.1 Use a square gas burner, as described in Figs. 5 and 6, and Fig. 7.

7.8.2 Construct the 250 ± 10 by 250 ± 10 mm (approximately 10 by 10 in.) square burner of 13 ± 1 mm (0.5 in.) outside diameter stainless steel tubing, with 0.89 ± 0.05 mm (0.035 in.) wall thickness (see Fig. 5). The front side shall have 14 holes pointing straight out and spaced 13 ± 1 mm (0.5 in.) apart and nine holes pointing straight down and spaced 13 ± 1 mm (0.5 in.) apart. The right and left sides shall have six holes pointing straight out and spaced 13 ± 1 mm (0.5 in.) apart and four holes pointing inward at a 45° angle and spaced 50 ± 2 mm (2 in.) apart. All holes shall be of 1 ± 0.05 mm (0.039 in.) diameter (see Fig. 5, Fig. 6, and Fig. 7). The straight arm of the burner shall be 1.07 ± 0.05 m (42 in.) long and welded on to the rear of the front side (see Fig. 5) at a 30° angle. Mount the burner on an adjustable height pole at a height of 460 ± 13 mm (18 ± 0.5 in.) and balance it by a counterweight or other appropriate mechanism (see Fig. 8).

NOTE 2—**Caution:** It is common for the burner holes to become clogged up following a test. Inspect burner holes after each test, and clean thoroughly, if required. Take care not to enlarge the holes when cleaning them.

7.8.3 The burner is described in detail in Ref. (2).

7.8.4 Use propane gas, with a known net heat of combustion of 2050 ± 50 kJ/mol, as a fuel for this ignition source. Meter the flow rate of propane and keep it constant throughout the test.

7.8.5 Use the gas burner at a flow rate of 13 ± 0.25 L/min for a total of 80 s. Measure the gas flow rate at a pressure of 101 ± 5 kPa (standard atmospheric pressure, measured at the

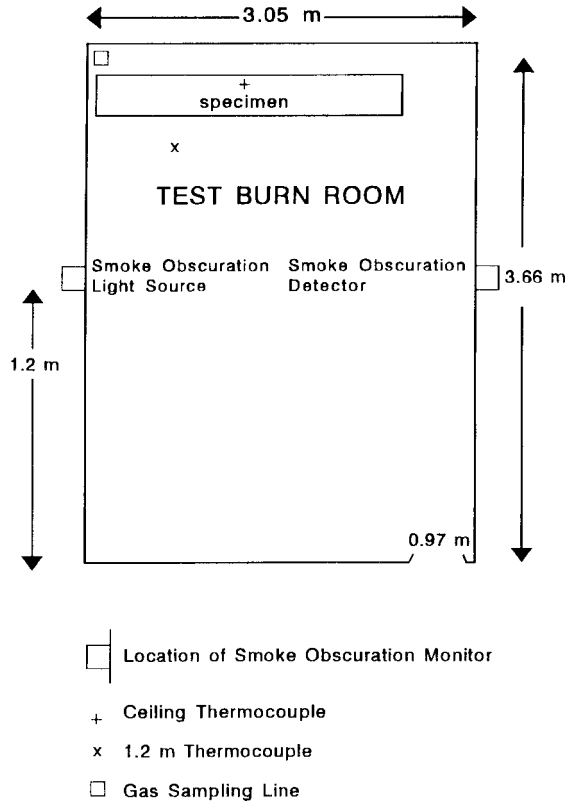

NOTE 1—See text for tolerances; room instrumentation is optional.

FIG. 4 Test Room Configuration for Option B for Items of Furniture Between 1 and 2.44 m Across

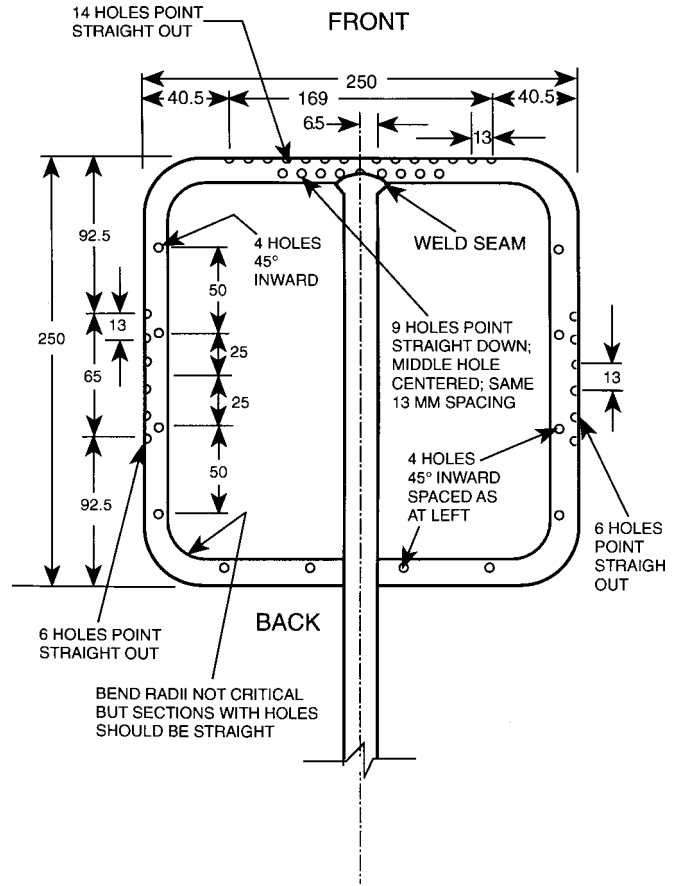

NOTE 1—All tubing 13 mm outside diameter, stainless steel, 0.89 mm wall thickness.

NOTE 2—All holes 1 mm in diameter.

NOTE 3—All units are mm unless otherwise noted.

NOTE 4—See text for tolerances.

FIG. 5 Plan View of Square Gas Burner

flow gage) and a temperature of $20 \pm 5^\circ\text{C}$. The approximate ratio of heat release rate output to gas flow rate is 1.485 kW min/L, under standard conditions.

7.9 Location of Gas Burner:

7.9.1 If the furniture specimen is less than 1.0 m wide (overall), place the gas burner at the center of the furniture seating surface, 50 ± 5 mm (2 ± 0.2 in.) away from the furniture back and 25 ± 5 mm (1 ± 0.2 in.) above the seating surface.

7.9.2 Test any specimen over 1.0 m wide with the gas burner located at 125 ± 10 mm (5 ± 0.4 in.) from the side of the piece of furniture, 50 ± 5 mm (2 ± 0.2 in.) away from the furniture back and 25 ± 5 mm (1 ± 0.2 in.) above the seating surface.

7.9.3 In order to facilitate repeatability and reproducibility, it has been found useful to determine the exact location of the gas burner on the furniture by using a back line marker gage.

7.10 Mass Loss Measurements:

7.10.1 Use a weighing platform to continuously measure the mass of the burning specimen. Construct a weighing platform, consisting of a horizontal thermal barrier, as described in 7.10.2 and 7.10.3, and placed on top of a mass measuring device.

7.10.2 Construct a thermal barrier large enough to prevent melting or falling material from the tested furniture specimen from falling off the thermal barrier. The barrier shall be used to protect the load cell.

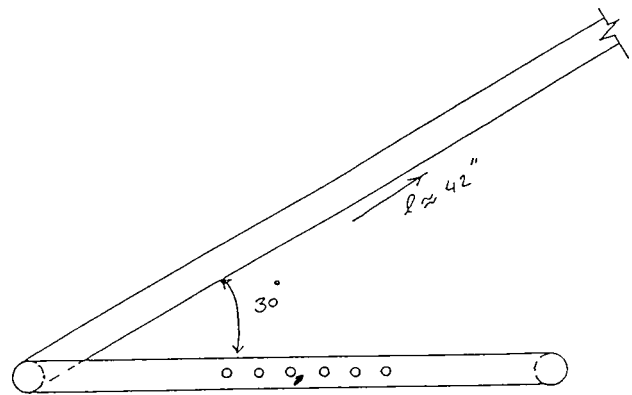

FIG. 6 Side View of Square Gas Burner

7.10.3 The barrier shall consist of a galvanized steel pan with gypsum board lining placed under the furniture specimen. The pan shall be constructed of nominally 1.6-mm ($1/16$ in.) thick steel, and have dimensions of no less than 1.0 by 1.0 m (which corresponds to approximately 39 by 39 in.), with a uniform raised lip of the same material, 100 ± 10 mm (approximately 4 in.) high, on each side, to catch falling

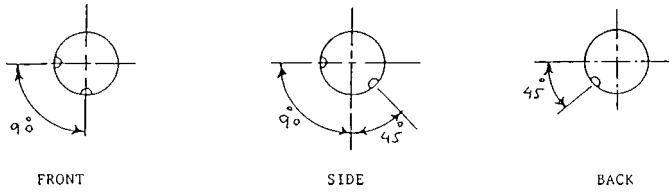
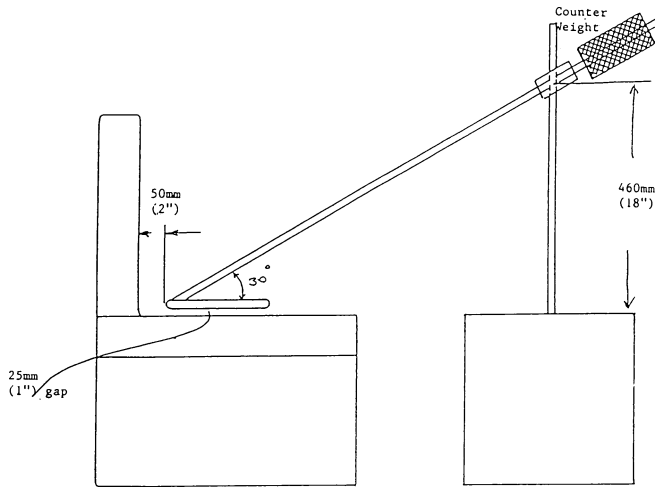

FIG. 7 Cross-sectional View of Each Side of Square Gas Burner



NOTE 1—See text for tolerances.

FIG. 8 Positioning of Square Gas Burner on a Chair

material. The bottom of the pan shall be covered by a tight fitting section of standard gypsum board (finish side up), of nominally 13 mm (0.5 in.) thickness. The gypsum board shall be clean before the start of a test; the board shall be replaced for each test. Pans with dimensions of 1.2 ± 0.1 by 2.1 ± 0.1 m (4 ft \pm 4 in. by 8 ft \pm 4 in.) have been found satisfactory for testing large furniture specimens.

7.10.4 Measure the specimen mass continuously with a device capable of an accuracy of no less than ± 150 g, up to at least 90 kg. Install it in such a way that neither the heat from the burning specimen nor any eccentricity of the load affect the accuracy. Do not make any range shifts during measurements. Install all parts of the mass measuring device below the top level of the thermal barrier.

7.10.5 The distance from the upper surface of the thermal barrier to floor level shall not exceed 0.5 m (20 in.). The area between the thermal barrier and the floor level shall be shielded in order to avoid lifting forces, due to fire induced air flow, that influence the measurement.

8. Exhaust Collection System

8.1 General:

8.1.1 The exhaust collection system shall consist of a blower, steel hood, duct, bidirectional probe, thermocouple(s), oxygen measurement system, smoke obscuration measuring system (white light photocell lamp/detector or laser), and combustion gas sampling and analysis system. It shall be constructed as shown in Fig. A2.1 and as explained in Annex A2.

8.1.2 The system for collecting the combustion products shall have a capacity and be designed in such a way that all of

the combustion products leaving the burning specimen are collected. Design the capacity of the evacuation system so as to exhaust all combustion gases leaving the furniture specimen (see A2.1.4).

8.1.3 Place probes for sampling of combustion gas and for measurement of flow rate in accordance with 8.2.

8.1.4 Measure all combustion product (smoke obscuration and gas concentrations) at a position in the exhaust duct where the exhaust is uniformly mixed and there is a nearly uniform velocity across the duct section. A distance of 10 to 30 duct diameters is satisfactory for this purpose.

8.2 Details of Instrumentation in Exhaust Duct:

8.2.1 The following specifications are minimum requirements for exhaust duct instrumentation. Additional information is found in Annex A3.

8.2.2 *Flow Rate*—Measure the flow rate in the exhaust duct by means of a bidirectional probe located at the center line of the duct (see A3.1 for further details). Measure the flow rate in the exhaust duct with an accuracy of at least $\pm 6\%$. The response time to a stepwise change of the duct flow rate shall be a maximum of 5 s to reach 90 % of the final value.

8.2.3 Combustion Gas Analysis:

8.2.3.1 *Sampling Line*—Make the sampling line tubes of a material not influencing the concentration of the combustion gas species to be analyzed. The recommended sequence of the gas train is: sampling probe, soot filter, cold trap, gas path pump, vent valve, plastic drying column and carbon dioxide removal columns (if used), flow controller and oxygen analyzer (see Fig. 9 and A3.2 for further details). The gas train shall also include appropriate spanning and zeroing facilities.

8.2.3.2 *Oxygen Measurement*—Measure the oxygen concentration with an accuracy of at least $\pm 0.04\%$ of full scale in the output range of 0 to 21 vol % oxygen, or ± 0.01 vol % oxygen, in order to have adequate measurements of rate of heat release. Take the combustion gas sample from the end of the sampling line. Calculate the time delay, including the time constant of the instrument, from the test room; it is a function of the exhaust duct flow rate. It shall be a maximum of 30 s. (See A3.3 for further details.) A discussion of the calculations for rate of heat release is given in Annex A4.

8.2.3.3 *Carbon Monoxide and Carbon Dioxide Measurement*—Measure the combustion gas species with an instrument having an accuracy of at least ± 0.1 vol % for carbon dioxide and ± 0.02 vol % for carbon monoxide. A suitable output range is 0 to 1 vol % for carbon monoxide and 0 to 6 vol % for carbon dioxide. Take the combustion gas

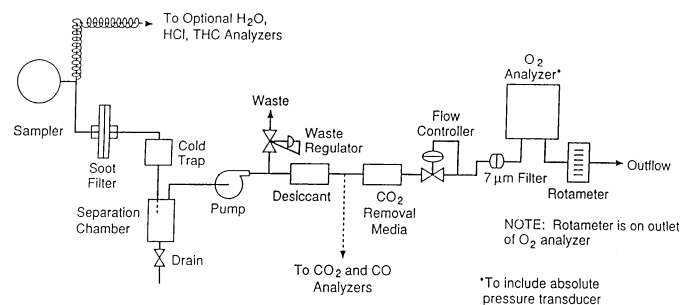

FIG. 9 Schematic of Gas Train

sample from the end of the sampling line. Calculate the time delay, including the time constant of the instrument, from the test room; it is a function of the exhaust duct flow rate. It shall be a maximum of 30 s. (See A3.3 for further details.)

8.2.4 *Smoke Obscuration Measurement*—Install an optical system for measurement of light obscuration across the centerline of the exhaust duct. Determine the optical density of the smoke by measuring the light transmitted with a photometer system consisting of a lamp, plano convex lenses, an aperture, a photocell, and an appropriate power supply. See Fig. 10 and A3.4 for further details. Construct the system so that soot deposits on the optics during a test do not reduce the light transmission by more than 5 %. Alternatively, instrumentation using a laser beam system, with an 0.5 to 2.0 mW helium-neon laser, instead of white light system is also acceptable. See Fig. 11 and A3.4 for further details. It has been shown that white light and laser systems will give similar results (see Refs (3-6)).

9. Calibration

9.1 Calibrate all instruments carefully with standard sources after initial installation. Among the instruments to be calibrated are load cells or weighing platforms, smoke meters, flow or velocity transducers, and gas analyzers. Perform recalibration tests on the entire system, for example, using standard output burners.

9.2 Heat Release:

9.2.1 Perform the calibration of the heat release instrumentation in the exhaust duct by burning propane or methane gas and comparing the heat release rates calculated from the metered gas input and those calculated from the measured oxygen consumption. The value of net heat of combustion for methane is 50.0 MJ/kg and that for propane is 46.5 MJ/kg. Position the burner in the same location where the upholstered furniture specimen is to be placed during the test. Measure the gas flow rate at a pressure of 101 ± 5 kPa (standard atmospheric pressure, measured at the flow gage) and a temperature of $20 \pm 5^\circ\text{C}$.

9.2.2 A suitable calibration burner is a sand diffusion burner with a 0.3 by 0.3-m (12 by 12-in.) top surface and a 0.15-m (6-in.) depth. Construct such a gas burner with a 25 mm (1 in.) thick plenum. Alternatively, use a minimum 100 mm (4 in.) layer of Ottawa sand to provide the horizontal surface through which the gas is supplied. This type of burner is shown in Fig. 12. The gas supply to the burner shall be propane, of the same quality as that used for the ignition burner, or methane. The gas

for the burner flame shall not be premixed with air. Meter the flow rate of gas and keep it constant throughout the calibration test.

9.2.3 Another suitable calibration burner is a pipe, with an inner diameter of 100 ± 1.5 mm (4 in.), supplied with gas from beneath (see ISO 9705). The gas for the burner flame shall not be premixed with air.

9.2.4 Obtain a minimum of two calibration points. Obtain a lower heat release rate value of 40 kW and then a higher heat release rate value of 160 kW. Approximate propane flow rates for any required heat release rate value are estimated using the following constant: 1.485 kW min/L, determined at a pressure of 101 ± 5 kPa (standard atmospheric pressure, measured at the flow gage) and a temperature of $20 \pm 5^\circ\text{C}$. Accurate flow rates of propane gas are calculated using the mass flow rate (Eq A5.1 or Eq A5.2).

9.2.5 Take measurements at least once every 6 s and start 1 min prior to ignition of the burner. Determine the average rate of heat release over a period of at least 1 min by the oxygen consumption method and calculating the heat release rate from the gas mass flow rate and the net heat of combustion. The difference between the two values shall not exceed 5 %. Make this comparison only after steady state conditions have been reached.

9.2.6 Perform a calibration test according to 9.5 prior to each continuous test series. Perform a full basic calibration on a new system or when modifications are introduced.

9.2.7 When calibrating a new system, or when modifications are introduced, it is recommended to check the response time of the measuring system by the following test sequence:

Time, min	Burner Output, kW
0 to 5	0
5 to 10	40
10 to 15	160
15 to 20	0

Take measurements at least once every 6 s. The response of the system to a stepwise change of the heat output from the burner shall be a maximum of 12 s to 90 % of final value.

9.2.8 Check the precision of the system at various flow rates by increasing the flow in the exhaust duct in four steps, starting from $0.25 \text{ m}^3\text{s}^{-1}$ (at 0.1 MPa and 25°C) up to maximum. The recommended heat output from the burner is 160 kW. The change in measured rate of heat release, comparing time average values over 1 min, shall not be more than 10 % of the actual heat output from the burner.

9.2.9 The use of a higher rate of heat release for calibration, for example 500 kW, will generally lead to higher accuracy in test results.

9.3 *Mass Loss*—Perform calibration of the mass measuring device by loading the weighing platform with known masses corresponding to the measuring range of interest, to ensure that the requirements of accuracy in 7.10.3 are fulfilled. Carry out this calibration daily, prior to testing.

9.4 *Smoke Obscuration*—Calibrate the smoke meter initially to read correctly for two neutral density filters of significantly different values and also at 100 % transmission. Once this calibration is set, only the zero value of extinction coefficient (100 % transmission) needs to be verified each day,

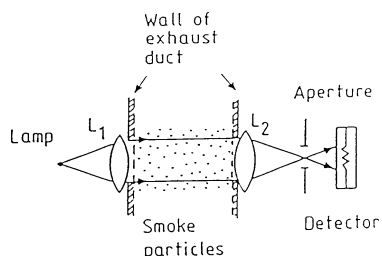

FIG. 10 Optical System, Using a White Light

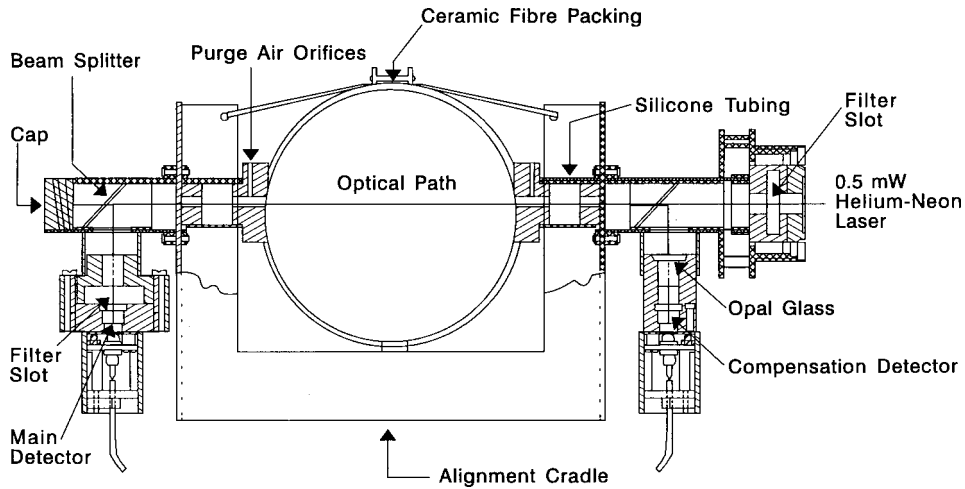
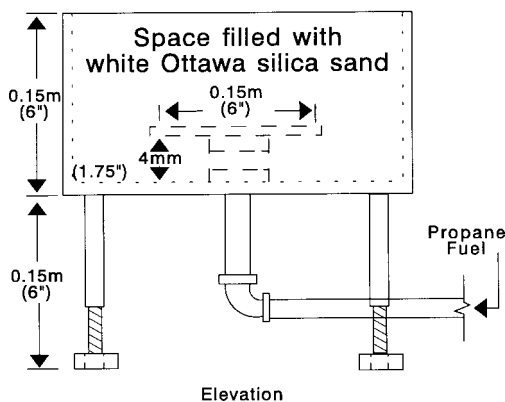
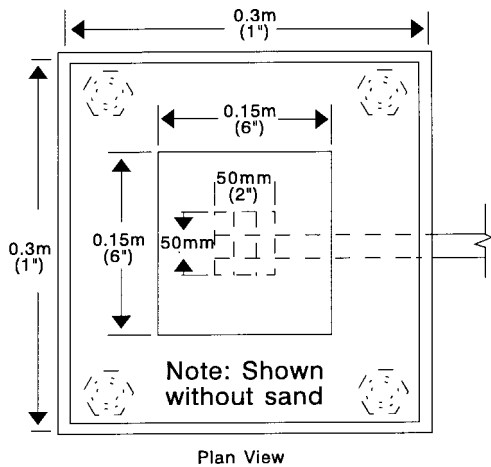

FIG. 11 Laser Extinction Beam



NOTE 1—See text for tolerances.
FIG. 12 Calibration Gas Burner

10. Conditioning

10.1 Prior to testing, condition the specimen for at least 48 h in an atmosphere at a temperature of $21 \pm 3^\circ\text{C}$ ($70 \pm 5^\circ\text{F}$) and a relative humidity of less than $55 \pm 5\%$. Test specimens within 10 min of removal from such conditions if test room conditions differ from the above.

11. Procedure

11.1 Initial Conditions:

11.1.1 The ambient temperature shall be above 15°C (60°F) and the relative humidity shall be less than 75 %.

11.1.2 The horizontal air flow, measured at the surface and at a horizontal distance of 0.5 m (20 in.) from the edge of the weighing platform, shall not exceed 0.5 m s^{-1} .

11.1.3 Position the specimen to be tested centrally on the weighing platform.

11.1.4 Have available means for extinguishing a fully developed fire.

11.2 Test Procedure:

11.2.1 Place the square gas burner above the seat cushion, as specified in 7.9.

11.2.2 Start all recording and measuring devices 2 min before starting the ignition burner.

11.2.3 Light the ignition burner.

11.2.4 Expose the specimen to the gas burner flames for 80 s, at a flow rate of 13 L/min, determine at a pressure of $101 \pm 5 \text{ kPa}$ (standard atmospheric pressure, measured at the flow gage) and a temperature of $20 \pm 5^\circ\text{C}$.

11.2.5 After the specified burning period extinguish the gas flame and remove the burner.

11.2.6 Perform a photographic or a video recording before and during each test. A clock shall appear in all photographic records, giving time to the nearest 1 s.

11.2.7 During the test record the following events and the time when they occur, with respect to the time of ignition of the burner:

- 11.2.7.1 Ignition of the specimen,
- 11.2.7.2 Position of flame front,
- 11.2.7.3 Melting and dripping,
- 11.2.7.4 Occurrence of pool fire under the specimen,

prior to testing. Investigate any excessive departure from the zero line at the end of a test, and correct it.

9.5 Gas Analysis— Calibrate gas analyzers daily, prior to testing (see Guide E 800 for further guidance).

11.2.7.5 General description of the burning behavior, and
 11.2.7.6 Any other event of special interest.

11.2.8 Terminate the test after the first of:

11.2.8.1 Burning has ceased,

11.2.8.2 One hour of testing has elapsed, or

11.2.8.3 Flashover appears inevitable.

11.2.9 Note, from visual inspection of the specimen after the test, the approximate percentage of each surface that was burned or charred, and the approximate depth of fire damage.

12. Calculation

12.1 Considerations for heat release measurements are presented in Annex A4. Calculate heat release data, using the equations presented in A5.1. The testing laboratory shall choose one of the equations in Annex A5 to calculate heat release.

12.2 Calculate smoke release data using the equations presented in A5.2.

12.3 Calculate gas yield data using the equations presented in A5.3.

13. Test Report

13.1 Report the following information:

13.1.1 *Descriptive Information:*

13.1.1.1 Name and address of the testing laboratory,

13.1.1.2 Date and identification number of the report,

13.1.1.3 Name and address of the test requester,

13.1.1.4 Test option used: A, B or C,

13.1.1.5 Name of product manufacturer or supplier, if known,

13.1.1.6 Name or other identification marks and description of the product,

13.1.1.7 Density, or mass per unit surface area, total mass, thickness of the main components in the specimen, and mass of combustible portion of specimen, if known,

13.1.1.8 Description of the specimen, if different from the product,

13.1.1.9 Conditioning of the specimens,

13.1.1.10 Date of test, and

13.1.1.11 Test number and any special remarks.

13.2 *Test Results* (see also Annex A1):

13.2.1 *Table of Numerical Results Containing:*

13.2.1.1 Peak rate of heat release (in kW) and the time at which it occurred,

13.2.1.2 Total heat released (in MJ),

13.2.1.3 Peak rate of smoke release (in m^2s^{-1}) and the time at which it occurred,

13.2.1.4 Total smoke released (in m^2),

13.2.1.5 Total mass loss (in kg),

13.2.1.6 Total percentage of mass loss (in %),

13.2.1.7 Peak concentration of carbon monoxide (in ppm),

13.2.1.8 Peak temperatures (in °C),

13.2.1.9 Equations used to calculate rate of heat release,

13.2.1.10 Peak optical density of smoke (optional),

13.2.1.11 Average optical density of smoke, over the 10 min period including the peak (optional),

13.2.1.12 Total percentage of combustible mass loss (in %) (optional),

13.2.1.13 Average yield of carbon monoxide (in g CO/g fuel) (optional),

13.2.1.14 Average yield of carbon dioxide (in g CO₂/g fuel) (optional),

13.2.1.15 Carbon monoxide/carbon dioxide molar yield ratio (optional),

13.2.1.16 Average yield of any other measured combustion gas (in g combustion gas/g fuel) (optional), and

13.2.1.17 Report smoke obscuration, carbon monoxide, and temperature measurements in the room in the same fashion, if they have been made (optional).

13.2.2 *Graphical Results (Optional):*

13.2.2.1 Plot of rate of heat release versus time,

13.2.2.2 Plot of rate of smoke release versus time,

13.2.2.3 Plot of optical density versus time,

13.2.2.4 Plot of mass loss versus time,

13.2.2.5 Plot of concentration of carbon monoxide versus time,

13.2.2.6 Plot of concentration of carbon dioxide versus time,

13.2.2.7 Plots of concentration of any other measured combustion gas versus time,

13.2.2.8 Plot of mass flow rate in the exhaust duct versus time,

13.2.2.9 Plot of duct temperature versus time, and

13.2.2.10 Report smoke obscuration, carbon monoxide, and temperature measurements in the room in the same fashion, if they have been made.

13.2.3 *Descriptive Results:*

13.2.3.1 Photographs or videotape of the fire development, and

13.2.3.2 All available information requested in 11.2.7.

14. Precision and Bias

14.1 *Precision*—The precision of this test method has not been determined. Table 1 and Table 2 show the precision obtained in an interlaboratory round-robin evaluation conducted with four laboratories, using four sets of upholstered chairs (labeled U1 to U4), supplied by different manufacturers, and all commercially available. Two of the laboratories conducted the tests using the “ASTM room,” and the other two used the “California room.” The data obtained from all four laboratories were analyzed. In Table 2, outliers and “obviously incorrect data” were excluded, using standard statistical considerations and information from the test lab reports submitted. It should be noted that some tests in some laboratories were incorrectly terminated before the mandated end point, after some guidelines were exceeded. The complete set of major data was also analyzed, without eliminating any data point, with the statistical analysis included as Table 3. It is possible to conduct an analysis of the data that excludes all incorrect data but does not exclude outliers, but that was not done. A research report has been submitted to ASTM that includes all the information required for a full understanding of results. The user is encouraged to consult this research report entitled, “Test Methods E 1537 and E 1822 Interlaboratory Study, Prepared by: ASTM E05.15” (2001). The abbreviations used are as follows: peak rate of heat release (Pk RHR), total heat released (THR), mass loss at 10 min (Mass Loss @ 10), peak rate of

TABLE 1 Intralaboratory and Interlaboratory Precision Results of Round Robin Evaluation Excluding Outliers and Incorrect Data

Chair	Property/Units	Average	STD repeat	STD Repro	R	R	RSD repeat	RSD Repro
U1	Pk RHR/kW	25.2	3.9	4.1	11.0	11.6	15.5	16.5
U2	Pk RHR/kW	799.7	364.3	364.3	1020.0	1020.0	57.5	57.5
U3	Pk RHR/kW	21.7	7.7	7.7	21.4	21.4	35.3	35.3
U4	Pk RHR/kW	37.8	18.9	18.9	52.8	52.8	50.0	50.0
U1	THR @ 10/MJ	2.5	1.2	1.3	3.5	3.5	48.6	49.6
U2	THR @ 10/MJ	76.6	26.3	28.3	73.6	79.4	34.4	37.0
U3	THR @ 10/MJ	1.7	1.3	1.3	3.5	3.5	68.6	68.6
U4	THR @ 10/MJ	3.1	1.5	1.5	4.2	4.2	48.6	48.6
U1	time to Pk RHR/s	141.6	17.0	52.3	47.7	146.3	12.0	36.9
U2	time to Pk RHR/s	229.3	40.6	78.7	113.5	220.3	17.7	34.3
U3	time to Pk RHR/s	108.4	29.6	54.2	82.8	151.6	27.3	49.9
U4	time to Pk RHR/s	112.2	28.1	58.8	78.6	164.6	25.0	52.4
U1	Mass Loss @ 10/kg	0.1	0.02	0.03	0.05	0.09	18.7	31.7
U2	Mass Loss @ 10/kg	2.8	2.0	2.0	5.5	5.5	71.1	71.1
U3	Mass Loss @ 10/kg	0.1	0.1	0.1	0.2	0.2	61.8	61.8
U4	Mass Loss @ 10/kg	0.4	0.07	0.2	0.2	0.7	18.6	64.6
U1	Pk RSR, m ² /s	2.0	0.2	1.3	0.4	3.6	7.8	64.6
U2	Pk RSR, m ² /s	6.1	1.7	3.4	4.8	9.5	28.2	55.6
U3	Pk RSR, m ² /s	1.4	0.9	1.0	2.4	2.7	63.9	71.9
U4	Pk RSR, m ² /s	1.7	2.5	2.5	7.0	7.0	143.3	143.3
U1	TSR, m ²	238.8	180.2	243.8	504.5	682.5	75.5	102.1
U2	TSR, m ²	862.8	393.6	571.9	1102.1	1601.3	45.6	66.3
U3	TSR, m ²	160.1	35.8	93.0	100.1	260.3	22.3	58.1
U4	TSR, m ²	543.3	546.9	622.7	1531.4	1743.7	100.7	114.6
U1	time to Pk RSR/s	80.2	19.2	19.2	53.6	53.6	23.9	23.9
U2	time to Pk RSR/s	207.3	18.0	23.6	50.5	66.0	8.7	11.4
U3	time to Pk RSR/s	85.3	6.9	6.9	19.3	19.3	8.1	8.1
U4	time to Pk RSR/s	96.8	9.4	11.8	26.3	32.9	9.7	12.2

smoke release (Pk RSR), total smoke released (RSR), standard deviation for repeatability and reproducibility (STD repeat and STD Repro), relative standard deviation for repeatability and reproducibility (RSD repeat and RSD Repro), repeatability (r) and reproducibility (R).

14.2 Bias:

14.2.1 No information is presented on the bias of the procedure in this test method because correct values of fire-test-response characteristics of upholstered furniture can only be defined in terms of a test method. Within this limitation, this test method has no known bias and can be accepted as a reference method.

14.2.2 For solid specimens of unknown chemical composition, as used in building materials, furnishings, and common occupant fuel load, it has been documented that the use of the oxygen consumption standard value of 13.1 MJ/kg oxygen for the net amount of heat released per unit of oxygen consumed for complete consumption, results in an expected error band of

$\pm 5\%$ compared to the true value. For homogeneous materials with only a single pyrolysis mechanism, this uncertainty is reduced by determining the net heat of combustion from oxygen bomb measurements and the stoichiometric oxygen/fuel mass ratio from ultimate elemental analysis. For testing relevant to this standard, this is not practical, since specimens are finished products, some of which are nonhomogeneous and capable of exhibiting degradation reactions. Therefore, for unknown specimens, a $\pm 5\%$ accuracy limit is seen. For reference materials, however, careful determination of the net heat released per unit of oxygen consumed can make this source of uncertainty substantially less.

15. Keywords

15.1 calorimetry; carbon dioxide; carbon monoxide; fire; fire-test-response; heat release; ignition; mock-up; oxygen consumption; smoke obscuration; toxic combustion gases; upholstered furniture

TABLE 2 Intralaboratory and Interlaboratory Precision Results of Round Robin Evaluation

Chair	# of labs	Average	STD repeat	STD Repro	r	R	RSD repeat	RSD Repro
Peak RHR/kW								
U1	3	32.2	21.2	23.6	59.4	66.1	65.8	73.3
U2	4	632.7	182.3	467.8	510.4	1309.8	28.8	73.9
U3	4	21.7	3.9	4.0	10.8	11.3	17.7	18.6
U4	4	152.7	233.1	233.1	652.7	652.7	152.7	152.7
Total Heat Released @ 10 min/MJ								
U1	3	2.54	0.89	1.5	2.5	4.2	35.0	59.1
U2	4	60.25	13.29	44.18	37.2	123.7	22.1	73.3
U3	4	1.83	0.63	0.89	1.8	2.5	34.4	48.6
U4	4	3.1	0.79	1.23	2.2	3.4	25.5	39.7
time to peak RHR/s								
U1	3	210.1	205.9	205.9	576.5	576.5	98.0	98.0
U2	4	230.1	22.2	124.6	62.2	348.9	9.6	54.2
U3	4	108.4	15.2	84.9	42.6	237.7	14.0	78.3
U4	4	418.8	648.2	648.2	1815.0	1815.0	154.8	154.8
Mass Loss @ 10 min/kg								
U1	3	0.14	0.11	0.13	0.3	0.4	78.6	92.9
U2	4	2.73	1.01	1.55	2.8	4.3	37.0	56.8
U3	4	0.11	0.04	0.05	0.1	0.1	36.4	45.5
U4	4	0.74	0.91	1.06	2.5	3.0	123.0	143.2
Peak RSR/m ² /s								
U1	3	2.01	0.12	2.23	0.3	6.2	6.0	110.9
U2	3	1.78	1.54	5.67	4.3	15.9	86.5	318.5
U3	4	1.47	0.23	1.38	0.6	3.9	15.6	93.9
U4	4	1.74	2.23	2.38	6.2	6.7	128.2	136.8
Total Smoke Released @ 10 min/m ²								
U1	3	238	180	368	504.0	1030.4	75.6	154.6
U2	3	689	731	888	2046.8	2486.4	106.1	128.9
U3	4	159.8	18.2	154	51.0	431.2	11.4	96.4
U4	4	286.2	115.1	354	322.3	991.2	40.2	123.7
Total Smoke Released entire test/m ²								
U1	3	239	180	367	504.0	1027.6	75.3	153.6
U2	3	929	381	983	1066.8	2752.4	41.0	105.8
U3	4	160.2	18.3	154	51.2	431.2	11.4	96.1
U4	4	529	496	865	1388.8	2422.0	93.8	163.5
time to peak RSR/s								
U1	3	136.8	170	171.4	476.0	479.9	124.3	125.3
U2	3	208.4	14	33	39.2	92.4	6.7	15.8
U3	4	85.3	4.26	4.38	11.9	12.3	5.0	5.1
U4	4	240.3	336.8	336.8	943.0	943.0	140.2	140.2

ANNEXES

(Mandatory Information)

A1. DESIGN OF MOCK-UP

A1.1 In lieu of testing finished products, full-scale mock-up testing is performed on mock-ups constructed according to the following specimen construction directives:

A1.1.1 The test specimen shall consist of component cushions that duplicate the thickness, construction, and design features of a product suitable for use.

A1.1.2 A metal test frame (see Fig. A1.1 and Fig. A1.2) shall be used to support seat and back cushions and, if necessary, arm cushions. The test frame shall be of steel construction. The back wall shall be constructed so that it is adjustable to a maximum angle of 135° from the horizontal

plane. The test frame shall be adjustable to accommodate test cushions of various thicknesses and sizes, with or without arm cushions.

A1.1.3 Component back, seat, and arm cushions shall be constructed into mock-up designs of the actual article of furniture. Construction shall duplicate all layers found in the actual article of furniture. Cushion construction shall consist of either:

A1.1.3.1 Manufacturer's prefabricated cushions of the appropriate size, or

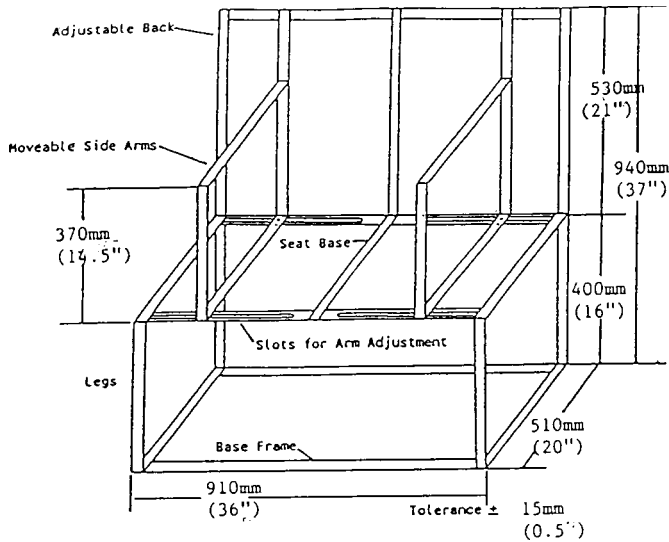

FIG. A1.1 Metal Test Frame

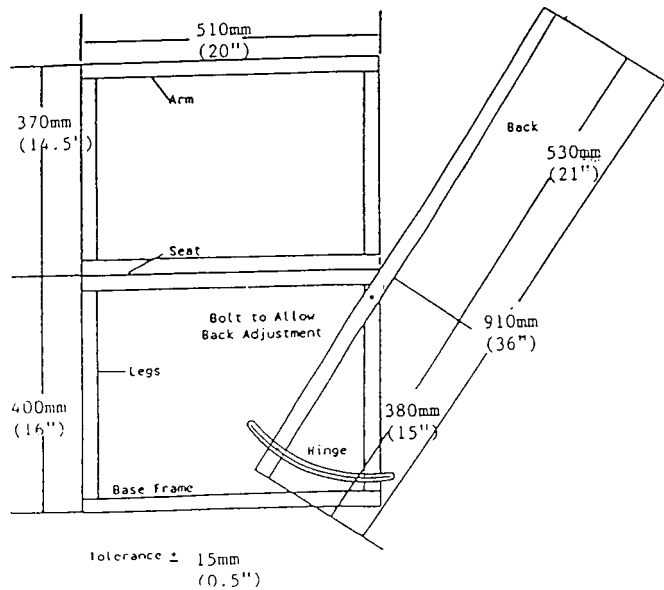

FIG. A1.2 Metal Test Frame (End View)

A1.1.3.2 Custom-made cushions of the appropriate size. Cushions are constructed by covering the face and four edges

of the filling material with the interliners, if appropriate, and cover fabric. On the back of each cushion, a 50 mm (2 in.) overlap of the cover fabric is stapled together, and a wire is loosely woven through the fabric edges and drawn to produce a close fit (see Fig. A1.3).

A1.1.4 The constructed seat cushion shall be placed horizontally on the seat area of the test frame and pushed against the back of the frame. The constructed back cushion shall then be placed vertically against the back support of the test frame. The back cushion shall be held in place by wire to prevent it from falling forward. If arm cushions are used, the constructed arm cushions shall be placed between the seat cushion and the arm supports of the test frame. However, the placement of the seat, back, and arm cushions shall be done to most closely duplicate the design features of the completed article of furniture. If any plastic frames or decorative parts are to be used, they shall also be included in the mock-up tested.

A1.1.5 The frame shall have a total length of 0.9 m (36 in.), a width of 0.5 m (20 in.), and an overall height of 0.93 m (37 in.). The back shall be hinged with 0.4 m (16 in.) from the seat to the floor and 0.53 m (21 in.) above the seat. The moveable side arms shall be 0.37 m (14.5 in.) high and 0.50 m (20 in.) wide (see Fig. A1.1). The tolerances of all measures shall be 12 mm (0.5 in.). The bottom of the frame shall be covered with a wire net having 45 ± 5 mm mesh size.

A1.1.6 The constructed cushions shall be 450 by 450 by 50 mm nominal thickness (18 by 18 by 2 in.). The thickness of the cushions may vary due to type of filling, presence of interliner, and type of fabric. The given cushion sizes are nominal for 50 mm foam thickness and shall be slightly adjusted to fit a given test set-up.

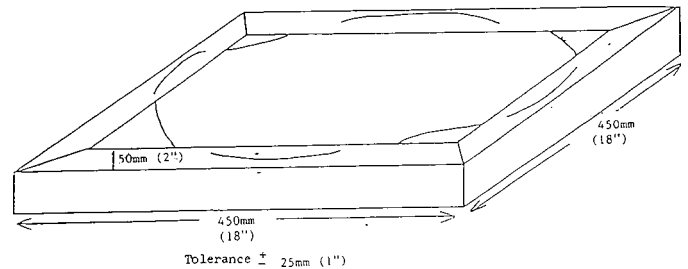

FIG. A1.3 Back View of Constructed Cushion

A2. DESIGN OF EXHAUST SYSTEM

A2.1 Hood and Exhaust Duct, Recommended Design:

A2.1.1 The combustion gases from the burning specimen shall be collected by a hood. Below, a system is described that has been tested in practice and proven to fulfill the specifications given in this test method.

A2.1.2 The hood is located just outside the room doorway. The bottom dimensions of the hood are 2.4 by 2.4 m (8 by 8 ft) and the height 1.0 m (see Fig. A2.1). The hood feeds into a plenum having a 0.9 by 0.9 m cross section area. The plenum has a height of 0.9 m. The maximum acceptable height is 1.8

m, depending on building constraints. In the plenum chamber two plates approximately 0.5 by 0.9 m are located (see Fig. A2.1) to increase mixing of the combustion gases. The hood shall be designed and manufactured so that no leakage exists. A suitable means of mounting the laser beam together with the combustion gas sampling probes is shown in Fig. A2.2.

A2.1.3 An exhaust duct is connected with the plenum chamber. The inner diameter of the exhaust duct is 405 ± 5 mm (16 in.). To facilitate flow measurements, guide vanes, if needed, are located at both ends of the exhaust duct (see Fig. A2.1). Alternatively, the rectilinear part of the exhaust duct must have such a length that a fully developed flow profile is established at the point of measurement. The exhaust duct is connected to an evacuation system.

A2.1.4 The capacity of the evacuation system shall be designed to exhaust all combustion gases leaving the specimen. This requires an exhaust capacity of at least 2.7 kgs^{-1} (about $8000 \text{ m}^3 \text{ h}^{-1}$ at standard atmospheric conditions) corresponding to a driving under pressure of about 2 kPa at the end of the duct. It shall be possible to control the exhaust flow from about 0.5 kgs^{-1} up to maximum flow, as stated above, during the test process. The system shall be capable of measuring low rates of heat release with sufficient sensitivity. If concentration gradients are found to exist, mixing vanes are an adequate means of addressing the problem.

A2.1.5 Use of an alternative exhaust system design is limited to those systems shown to produce equivalent results. Equivalency is demonstrated by meeting the calibration requirements under Section 9. Exhaust system designs based on natural convection are not permitted.

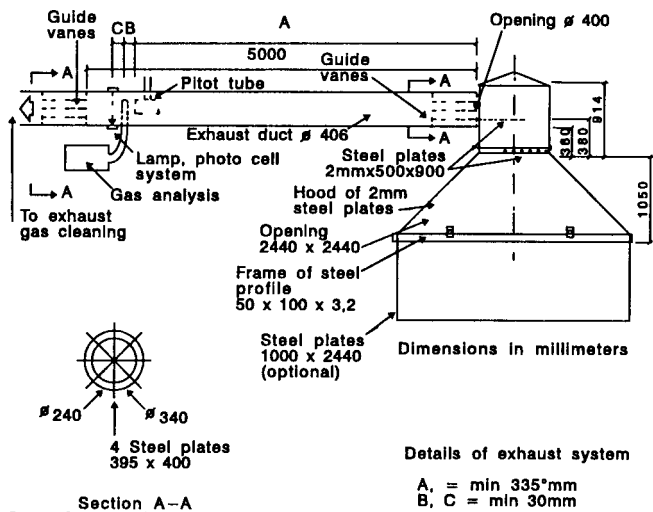

NOTE 1—Details of exhaust system: A = 3350 mm, min and B, C = 30 mm, min.

FIG. A2.1 Design of Hood and Exhaust System

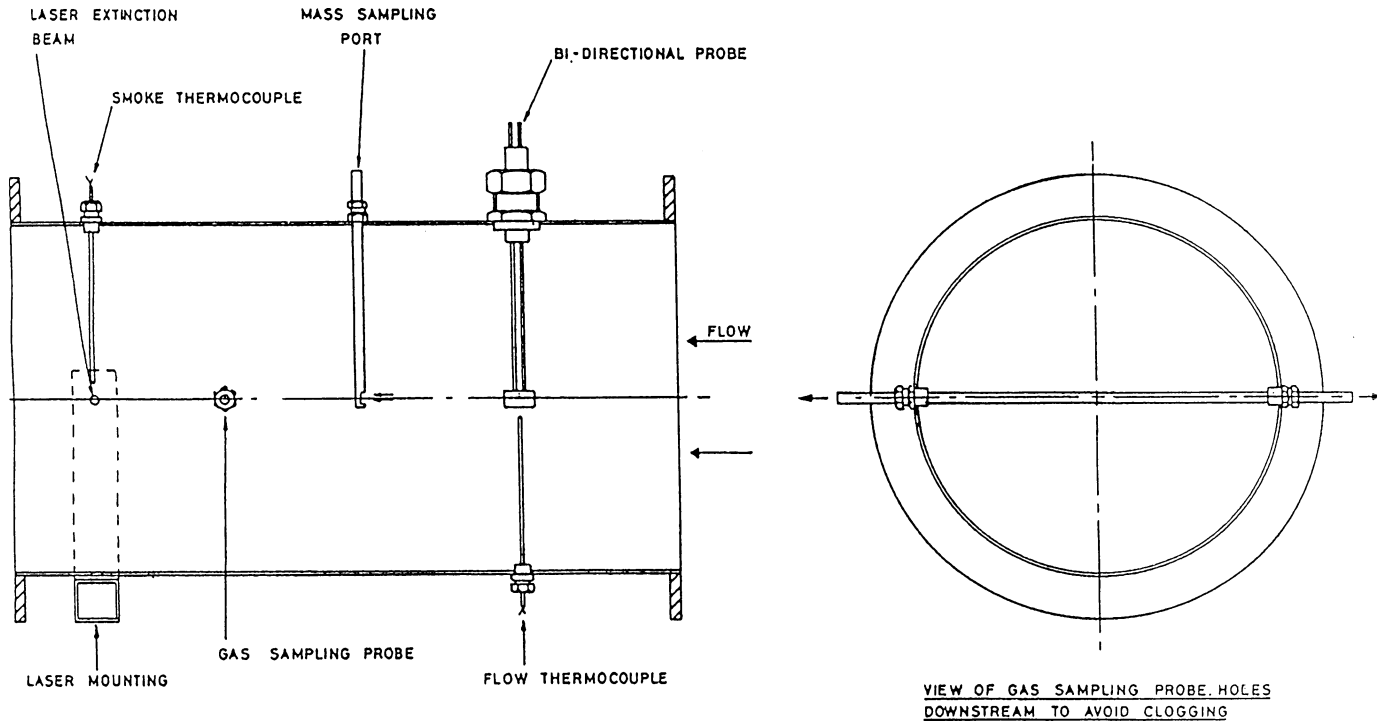

FIG. A2.2 Recommendations for Mounting the Laser Beam and Other Instrumentation in Exhaust Duct

A3. INSTRUMENTATION IN EXHAUST DUCT

A3.1 Flow:

A3.1.1 The flow shall be measured by a bidirectional probe located at the center line of the duct. The probe shown in Fig. A3.1 consists of a stainless steel cylinder, 32 mm long and with an inner diameter of 14 mm. The cylinder has a massive wall in the center, dividing it into two chambers. The pressure difference between the two chambers is measured by a pressure transducer.

A3.1.2 The pressure transducer shall have an accuracy of at least ± 5 Pa and be of the capacitance type. A suitable range of measurement is 0 to 2000 Pa.

A3.1.3 Gas temperature in the immediate vicinity of the probe is measured by a Chromel-Alumel Type K thermo-

couple, shielded against high heat with insulation resisting up to 1200°C. The wire gage shall be in the range 24 AWG (0.51 mm diameter) to 30 AWG (0.36 mm diameter). The thermocouple shall not be allowed to disturb the flow pattern around the bidirectional probe.

A3.2 Sampling Line:

A3.2.1 The sampling probe shall be located in a position where the exhaust duct flow is well-mixed. The probe shall have a cylindrical cross section so as to minimize disturbance of the air flow in the duct. Collect the combustion gas samples across the entire diameter of the exhaust duct (see Fig. A3.2).

A3.2.2 Manufacture the sampling line, Fig. 9, from corrosion resistant material, for example polytetrafluoroethylene. Remove the particulates contained in the combustion gases with inert filters, to the degree required by the gas analysis equipment. Carry out the filtering procedure in more than one

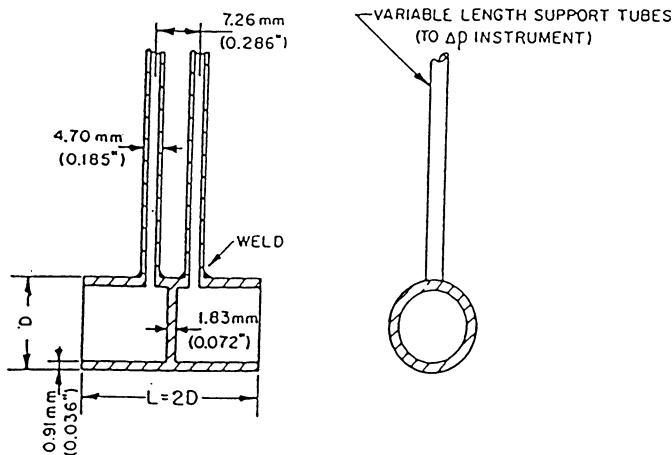

FIG. A3.1 Bidirectional Probe

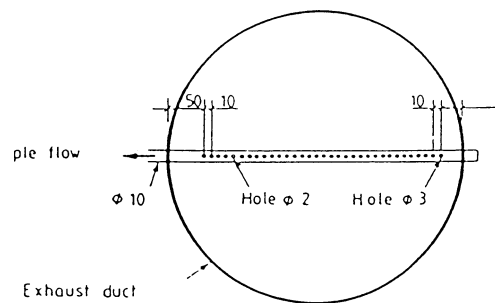

FIG. A3.2 Sampling Probe

step. Cool the combustion gas mixture to a maximum of 10°C. The combustion gas samples taken to each analyzer shall be completely dried.

A3.2.3 Transport the combustion gases by a pump, such as a diaphragm pump (coated with polytetrafluoroethylene), which does not emit oil, grease, or similar products. The presence of such products in the stream will contaminate the combustion gas mixture. Alternate pumps shown to have the same effect are acceptable, but they have often been shown to need frequent replacement.

A3.2.4 A suitable sampling probe is shown in Fig. A3.2. This sampling probe is of the bar type. When a bar type probe is not used, a ring type sampling probe is also acceptable. However, ring sampling probes will not allow combustion gas samples to be collected across the whole diameter of the duct. The sampling line is shown in Fig. 9. A pump with a capacity of 10 to 50 Lmin⁻¹ is suitable, as each combustion gas analysis instrument consumes about 1 Lmin⁻¹. The pump shall generate a pressure differential of at least 10 kPa to reduce the risk of smoke clogging of the filters. The intake of the sampling probe is turned downstream in order to avoid soot clogging in the probe.

A3.2.5 There shall be a soot filter capable of removing all particles >25 µm in size.

A3.2.6 The recommended approach to a cooling column (to remove water from the combustion gases) is to use a refrigerated column and separation chamber with a drain plug from which the collected water is removed from time to time (see Fig. 9). Alternate devices shown to give equivalent results are also acceptable.

A3.2.7 If carbon dioxide is to be removed, use carbon dioxide removal media, as indicated in Fig. 9.

A3.3 Combustion Gas Analysis:

A3.3.1 *Oxygen Concentration*—Use an oxygen analyzer, meeting the specifications under 8.2.3.2, preferably of the paramagnetic type, and including an absolute pressure transducer to compensate for gas pressure variations. Locate a rotameter on the outlet of the oxygen analyzer (see Fig. 9).

A3.3.2 *Carbon Monoxide and Dioxide Concentration*—Analyzers found suitable are nondispersive infrared analyzers. See Guide E 800 for further guidance.

A3.3.3 *Other Combustion Gases*—The concentration of other combustion gases, for example, water, total hydrocarbon, nitrogen oxide, hydrogen cyanide, or hydrogen chloride shall be measured when required for special purposes. See Guide E 800 for details of suitable analyzers.

A3.3.4 *Time Shift*—Combustion gas concentration measurements require the use of appropriate time shifts in order to

account for the time required for gas analyzer response and for combustion gas transit time within the sampling system. For each gas analyzer used, determine the system delay time for the analyzer to reach a 90 % response to a step change in the gas concentration.

A3.4 Smoke Obscuration:

A3.4.1 A suitable light measuring system based on white light has the following components: a lamp, plano convex lenses, an aperture, a photocell, and an appropriate power supply. Mount lenses, lamp, and photocell inside two housings, located on the exhaust duct, diametrically opposite each other.

A3.4.2 Use a lamp of the incandescent filament type, which operates at a color temperature of 2900 ± 100 K. Supply the lamp with stabilized direct current, stable within ±0.2 % (including temperature, short-term, and long-term stability). Center the resultant light beam on the photocell.

A3.4.3 Select the lens system such that the lens, L_2 , according to Fig. 10, has a diameter, d , chosen with regard to the focal length, f , of L_2 so that $d/f \leq 0.04$.

A3.4.4 Place the aperture in the focus of the lens, L_2 , according to Fig. 10.

A3.4.5 The detector shall have a spectrally distributed response according to the CIE photopic curve. The detector shall be linear within 5 % over an output range of at least 3.5 decades. Check this linearity periodically with calibrated optical filters, covering the entire range of the instrument.

A3.4.6 The system described below is an example of a light measuring system that has been found to be satisfactory:

A3.4.6.1 *Lenses*—Plano convex, diameter 40 mm, focal length 50 mm.

A3.4.6.2 *Lamp*—Osram Halo Stars, 64410: 6 V, 10 W.

A3.4.6.3 *Photocell*, United Detector Technology: PIN 10 AP.

A3.4.6.4 *Voltage Supply*—Gresham Lion Ltd: G × 012 model.

A3.4.7 The system shall be designed to be purged against soot deposits. The use of holes in the periphery of the two housings is a means of achieving this objective.

A3.4.8 An acceptable alternate system for measurements of smoke obscuration uses a helium-neon laser, and silicon photodiodes as main beam and reference detectors, respectively, and appropriate electronics to derive an extinction coefficient and to set a zero reading. The system is designed for split yoke mounting in two pieces that are rigidly coupled together, but resiliently attached to the exhaust duct by means of refractory gasketing. The assembly will project a 0.5 to 2.0 mW helium-neon laser beam horizontally across the exhaust duct (see Fig. 11).

A4. CONSIDERATIONS FOR HEAT RELEASE MEASUREMENTS

A4.1 *Measurement of Rate of Heat Release by Oxygen Consumption:*

A4.1.1 *Introduction*— In 1917, Thornton (7) showed that for a large number of organic fuels, a more or less constant net amount of heat is released per unit of oxygen consumed for complete combustion. Huggett (8) obtained an average value for this constant of 13.1 MJ/kg of O₂. This value may be used for practical applications and is accurate, with very few exceptions, to within ±5 %.

A4.1.1.1 Thornton's rule implies that it is sufficient to measure the oxygen consumed in a combustion system in order to determine the net heat released. This is particularly useful for full-scale fire test applications. For example, for compartment fires, the oxygen consumption technique is much more accurate and easier to implement than methods based on measuring all the terms in a heat balance of the compartment.

A4.1.1.2 Perhaps the first application of the O₂ consumption principle in fire research was by Parker (9) using Test Method E 84, the tunnel test. Later, Sensenig applied it to an intermediate scale room test (10). During the late seventies and early eighties, the O₂ consumption technique was refined at the National Institute for Standards and Technology (NIST, formerly National Bureau of Standards). A paper by Parker (11) gives equations to calculate rate of heat release by O₂ consumption for various applications. The technique is now used extensively in many laboratories all over the world, both in bench-scale (12) and full-scale (13)¹¹ fire test applications.

A4.1.1.3 The objective of this annex is to provide a comprehensive set of equations and guidelines to determine the rate of heat release in full-scale fire tests based on the O₂ consumption principle. The approach followed here is somewhat different from Parker (11) as the emphasis is on full-scale fire test applications and the use of volumetric flow rates is avoided. Volumetric flow rates require specification of temperature and pressure. Various investigators have used different combinations of reference pressure and temperature. This leads to confusion, which is greatly minimized if mass flow rates are used.

A4.1.1.4 The basic requirement is that all combustion products be collected in a hood and removed through an exhaust duct. At a distance downstream of the hood sufficient for adequate mixing, both flow rate and composition of the combustion gases are measured. We assume it is not possible to measure the air flow rate into the system, as this is generally the case for full-scale fire tests. The differences in treatment and equations to be used are mainly due to the extent to which combustion gas analysis is made. At least O₂ shall be measured, but, if additional instrumentation is available, heat release rate measurements will be more accurate by measuring CO₂ and CO additionally.

A4.1.2 It must be emphasized that the analysis is approximate. The following list describes the main simplifying assumptions made:

A4.1.2.1 The amount of energy released by complete combustion per unit of oxygen consumed is taken as: $E = 13.1$ MJ/kg of O₂.

A4.1.2.2 All combustion gases are considered to behave as ideal gases, in other words 1 mol of any gas is assumed to occupy a constant volume at the same pressure and temperature.

A4.1.2.3 Incoming air consists of O₂, CO₂, H₂O, and N₂. All inert gases, which do not take part in the combustion reactions, are lumped into the nitrogen.

A4.1.2.4 The O₂, CO₂, and CO are measured on a dry basis, in other words, water vapor is removed from the sample before combustion gas analysis measurements are made.

A4.1.3 In the analysis to follow, initial emphasis will be placed on the flow rate measurement. Equations to calculate flow rate are applicable unless otherwise indicated, irrespective of the configuration of the combustion gas analysis system. In subsequent sections, distinction is made between various combustion gas analyzer combinations.

A4.2 *Flow Rate Measurements:*

A4.2.1 Mainly two techniques are used to measure mass flow rate in the exhaust duct of full-scale fire tests.

A4.2.2 The first technique measures mass flow rate via the pressure drop across, and temperature at, an orifice plate (see Eq A5.1). If the test is conducted within a narrow range of conditions, the orifice plate coefficient, C , is approximately constant. Determine the value of the orifice plate coefficient using a burner calibration or an alternative method that provides equivalent results. However, if flow rates are varied during a test or if temperature changes are considerable, effect on C of the Reynolds number and pressure at the downstream side of the orifice plate must be taken into account. Information on such corrections and on various design options (for example, location of the pressure taps) are found in Ref. (14).

A4.2.3 The other technique is to measure velocity at one point in the duct, usually along the center line. The flow rate is then calculated using a predetermined shape of the velocity profile in the duct. The latter is obtained by measuring velocity at a sufficient number of representative points over the diameter or cross section of the duct prior to any fire tests. Detailed procedures to obtain this profile are described in (15). Usually, conditions in full-scale fire tests are such that the flow in the duct is turbulent, resulting in a shape factor k_c (= ratio of the average velocity to the velocity along the centerline) close to 1.

A4.2.4 Due to considerable soot production in many fires, pitot static tubes cannot be used because of clogging of the holes. This is unlikely to cause a problem in a test of a single item of upholstered furniture, but is worth bearing in mind. In order to deal with this problem, a more robust bidirectional probe was designed by McCaffrey and Heskestad (16). This involves measuring the differential pressure across the probe

¹¹ ASTM "Proposed Method for Room Fire Test of Wall and Ceiling Materials and Assemblies," *ASTM Annual Book of Standards*, Vol 04.07, p. 958, 1983.

and the centerline velocity (see Eq A5.2), and is valid in the range of Reynolds numbers, Re :

$$40 < Re < 3800$$

In many full-scale fire test applications, duct diameter and flow rate are such that the Reynolds number is:

$$Re > 3800$$

In this case $f(Re)$ is taken as a constant (1.08), which greatly simplifies the calculations. This equation (see Eq A5.2) is generally preferred for full-scale measurements of heat release rate. Further details of this and of all other calculations discussed in this annex are found in a paper by Janssens (17). For additional details see ISO 9705.

A4.3 *Rate of Heat Release Measurement if Only Oxygen is Measured:*

A4.3.1 In this case all water vapor and CO_2 are eliminated by the use of appropriate filtering media. This leads to the assumption that the sample combustion gas only consists of O_2 and N_2 . This is approximately true provided CO production is negligible. As the composition of the incoming air is unlikely to change during a test, and as the temperatures in building fires are usually not high enough to generate noticeable amounts of nitrogen oxides by nitrogen fixation, the mole fraction of O_2 in the air, as measured by the analyzer prior to a test, can be written on the basis of O_2 and N_2 exclusively. The mole fraction of O_2 in the exhaust combustion gases, as measured by the oxygen analyzer, can be written likewise. As nitrogen is conserved and does not participate in the combustion reactions, the equations are derived on the basis of its conservation.

A4.3.2 In this case the rate of heat released (in kW) is calculated as a function of the heat released per unit of oxygen consumed (E , 13.1 MJ/kg of O_2), the ratio of the molecular weight of oxygen (M_1 , 32.0 kg/kmol) and the molecular weight of the incoming air (M_2 , generally taken as 28.97 kg/kmol), the mass flow rate of the incoming air (in kg/s) and the humidity of the incoming air. The flow rate measured is that of the smoke within the exhaust duct and not that of the incoming air. In order to find a relation between the two it is necessary to define the oxygen depletion factor. The oxygen depletion factor is the fraction of the incoming air that is fully depleted of its oxygen (see Eq A5.3). It has been demonstrated (see Appendix in Test Method E 1354) that the rate of heat release is a function of E , M_1 , M_2 , and the oxygen depletion factor, plus the expansion factor. The expansion factor has to be assigned, and a recommended value is 1.105, the value for methane. The value for propane is 1.084, that for carbon in dry air is 1.0, and that for hydrogen is 1.21.

A4.3.3 The resulting equation (Eq A5.4) is expected to be accurate to within $\pm 5\%$, provided combustion is complete; in other words, all carbon is converted to CO_2 . Errors will be larger if CO or soot production is considerable or if a significant amount of the combustion products are other than CO_2 and H_2O . It is unlikely that these errors will be of concern for a single item of upholstered furniture.

A4.4 *Rate of Heat Release Measurement if Oxygen and Carbon Dioxide are Being Measured*—This case is similar to that covered in Eq A5.3. It is now assumed that only water vapor is trapped before the sample reaches the combustion gas analyzers. Again, the equations are derived on the basis of conservation of nitrogen. The mole fraction of CO_2 in the incoming air is taken to be 330 ppm. A new equation is now needed, of course, for the oxygen depletion factor: Eq A5.4. Again the equation for rate of heat release (see Eq A5.3) is accurate to within $\pm 5\%$, provided combustion is complete; in other words, all carbon is converted to CO_2 .

A4.5 *Rate of Heat Release Measurement if Oxygen, Carbon Dioxide, and Carbon Monoxide are Being Measured*—This case reverts to that covered in A2.4 if CO production is negligible. Taking CO into account, however, changes the equations. It means that a new oxygen depletion factor is required, Eq A5.6, as well as a new rate of heat release equation altogether, Eq A5.7.

A4.6 *Calculation of Heat Released by Igniting Fuel:*

A4.6.1 Part of the oxygen depletion in the exhaust duct is due to the combustion of the ignition source fuel. This part must be subtracted from the total oxygen depletion in order to determine the net rate of heat release of the specimen.

A4.6.2 For a gas burner, Janssens has derived an equation to take into account this value (17). However, in view of the delay in response of the instrumentation in the exhaust duct, the problem of filling of an enclosure, and other experimental difficulties, it is recommended that the best way to measure the net heat released by the specimen is to subtract from the heat obtained in the equations the heat release measured in the calibration. This heat yields a baseline rate of heat release curve.

A4.7 *Conclusions:*

A4.7.1 Depending on the configuration of combustion gas analyzers and the type of flow rate measurement, one of the following procedures shall be used to calculate rate of heat release:

A4.7.2 *Case 1*—Only O_2 is measured:

A4.7.2.1 Calculate the mass flow rate of the exhaust combustion gases,

A4.7.2.2 Calculate the oxygen depletion factor, and

A4.7.2.3 Calculate the rate of heat release.

A4.7.3 *Case 2*—Both O_2 and CO_2 are measured:

A4.7.3.1 Calculate the mass flow rate of the exhaust combustion gases as in A4.7.2,

A4.7.3.2 Calculate the new oxygen depletion factor, and

A4.7.3.3 Calculate the new rate of heat release.

A4.7.4 *Case 3*— O_2 , CO_2 , and CO are measured:

A4.7.4.1 Calculate the mass flow rate of the exhaust combustion gases as in A4.7.2,

A4.7.4.2 Calculate the new oxygen depletion factor, and

A4.7.4.3 Calculate the new rate of heat release.

A4.7.5 Carbon dioxide is eliminated from the combustion gas sample because it influences the oxygen measurement. If a CO_2 analyzer is used, this eliminates the need for removal of CO_2 from the combustion gas sample. This is mainly of

practical importance as the scrubbing agent used to remove CO₂ usually requires careful handling and is rather expensive. If significant amounts of CO are produced (for example, at or beyond flashover in ventilation controlled room fires), accuracy of the rate of heat release measurement is greatly improved if CO is measured.

A4.7.6 The presence of a water vapor analyzer simplifies the analysis and improves accuracy even more. Unfortunately,

implementation of a water vapor analyzer is not straightforward because sampling lines, filters, etc. must be heated to avoid condensation. Thus, the use of a water vapor analyzer precludes the estimation of the expansion factor. For this test method, the use of water analyzers is not recommended.

A5. MEASUREMENT EQUATIONS

A5.1 *Rate of Heat Release*—Symbols are explained in A5.4.

A5.1.1 *Flow Rate:*

A5.1.1.1 *Pressure Drop Measurement (see Eq A5.1):*

$$\dot{m}_e = C \times \sqrt{\left[\frac{\Delta p}{T_e}\right]} \quad (\text{A5.1})$$

A5.1.1.2 *Velocity Measurement (see Eq A5.2):*

$$\dot{m}_e = 26.54 \times \frac{A \times k_c}{f(Re)} \times \sqrt{\left[\frac{\Delta p}{T_e}\right]} \quad (\text{A5.2})$$

The preferred measurement method uses Eq A5.1. If Eq A5.2 is used, determine k_c daily, by calibration.

A5.1.2 *Case 1*—Only O₂ concentration measurements are used. Calculate the rate of heat release in accordance with Eq A5.3:

$$\dot{Q}(t) = E \times 1.10 \times C \sqrt{\left[\frac{\Delta p}{T_e}\right]} \times \left[\frac{(X_{O_2}^\circ - X_{O_2})}{1.105 - 1.5 \times X_{O_2}^\circ}\right] \times (1 - X_{H_2O}^\circ) \quad (\text{A5.3})$$

Set the value of E for the test specimen equal to 13.1×10^3 kJ/kg unless a more exact value is known for the test material.

A5.1.3 *Case 2*—Only O₂ and CO₂ concentration measurements are used. Calculate the mass flow rate in accordance with Eq A5.1 or Eq A5.2 and the oxygen depletion factor in accordance with Eq A5.4:

$$\phi = \frac{X_{O_2}^\circ \times [1 - X_{CO_2}] - X_{O_2} \times [1 - X_{CO_2}^\circ]}{X_{O_2}^\circ \times [1 - X_{O_2} - X_{CO_2}]} \quad (\text{A5.4})$$

and the rate of heat release in accordance with Eq A5.5:

$$\dot{Q}(t) = E \times \frac{\phi}{1 - \phi(\alpha - 1)} \times \dot{m}_e \times \frac{M_{O_2}}{M_a} \times (1 - X_{H_2O}^\circ - X_{CO_2}^\circ) \times X_{O_2}^\circ \quad (\text{A5.5})$$

A5.1.4 *Case 3*—O₂ and CO₂ and CO concentration measurements are used. Calculate the mass flow rate in accordance with Eq A5.1 or Eq A5.2 and the oxygen depletion factor in accordance with Eq A5.6:

$$\phi = \frac{X_{O_2}^\circ \times [1 - X_{CO_2} - X_{CO}] - X_{O_2} \times [1 - X_{CO_2}^\circ]}{X_{O_2}^\circ \times [1 - X_{O_2} - X_{CO_2} - X_{CO}]} \quad (\text{A5.6})$$

Finally calculate the rate of heat release in accordance with Eq A5.7:

$$\dot{Q}(t) = \left[E \times \phi - (E_{CO} - E) \times \frac{1 - \phi}{2} \times \frac{X_{CO}}{X_{O_2}} \right] \times \frac{\dot{m}_e}{1 + \phi \times (\alpha - 1)} \times \frac{M_{O_2}}{M_a} \times (1 - X_{H_2O}^\circ) \times X_{O_2}^\circ \quad (\text{A5.7})$$

A5.2 *Smoke Measurement Equations:*

A5.2.1 *Optical Density (OD)* (see Eq A5.8):

$$OD = \log[I_0/I] \quad (\text{A5.8})$$

A5.2.2 *Extinction Coefficient (k)* (see Eq A5.9):

$$k = (1/L_p) \times \ln(I_0/I) \quad (\text{A5.9})$$

A5.2.3 The volumetric flow rate is calculated as the product of the mass flow rate and the density of air, at the corresponding temperature. Thus, both the volumetric flow and the density of air must undergo temperature corrections. The volumetric duct flow rate (\dot{V}) is adjusted because it is measured in the exhaust duct, but required at the temperature near the photo-detector, as shown in Eq A5.10:

$$\dot{V}_s = \dot{V}_e \times \left(\frac{T_s}{T_e}\right) \quad (\text{A5.10})$$

A5.2.4 The density of air is adjusted between the literature value, measured at 273.15 K, and the value at the temperature in the exhaust duct, as shown in Eq A5.11:

$$\rho = \rho_o \times \frac{273.15}{T_e} \quad (\text{A5.11})$$

Then:

The final equation for the volumetric flow rate is Eq A5.12:

$$\dot{V}_s = \frac{\dot{m}_e}{\rho_o} \times \frac{T_e}{273.15} \quad (\text{A5.12})$$

Rate of smoke release (RSR) is defined by Eq A5.13:

$$RSR = [\dot{V}_s \times k] \quad (\text{A5.13})$$

Total smoke released (TSR) is defined by Eq A5.14:

$$TSR = \int RSR dt \quad (\text{A5.14})$$

A5.3 *Gas Yield Measurement Calculations:*

A5.3.1 Calculate the gas yields (f) using the following Eq A5.15:

$$f_x = \frac{\int \text{mass flow rate of gas}_x dt}{\text{mass loss of specimen}} \quad (\text{A5.15})$$

A5.3.1.1 The numerator in this equation is calculated by summing the product of the fraction of combustion gas by the total mass flow rate, measured at each scan, multiplying it by the total time period involved, and dividing by the number of scans, as shown in Eq A5.16:

$$f_x = \frac{(\sum_i ([x]_i \times m_{e(i)} \times \Delta t_i)) \times 0.001 \times \frac{M_x}{M_a}}{\text{mass loss of specimen}} \quad (\text{A5.16})$$

A5.3.1.2 In this equation, $[x]$, the concentration of gas x , is expressed in ppm, m_e , the mass flow rate, calculated by Eq A5.1 or Eq A5.2, is expressed in kg/s, M_x is the molecular weight of gas species x , Δt is the scan period and mass loss of specimen is the mass lost over the period over which the gas yield is calculated, and is expressed in g, with 0.001 a conversion factor to account for the unit changes.

A5.3.2 Gas concentrations shall be reported on a dry gas basis, unless water concentrations are being measured.

A5.4 Symbols:

A	= Cross sectional area of duct (m^2).
C	= Orifice plate coefficient ($\text{kg}^{1/2}\text{m}^{1/2}\text{K}^{1/2}$).
E	= Net heat released for complete combustion, per unit of oxygen consumed (13 100 kJ/kg O_2).
E_{CO}	= Net heat released for complete combustion per unit of oxygen consumed, for CO (17 600 kJ/kg O_2).
$f(\text{Re})$	= Reynolds number correction (nondimensional).
f_x	= Yield of gas x (g/g).
I	= Light intensity for a parallel light beam having traversed a certain length of smoky environment and reaching photodetector (nondimensional).
I_o	= Light intensity for a beam of parallel light rays, measured in a smoke-free environment, with a detector having the same spectral sensitivity as the human eye and reaching the photodetector (nondimensional).
K	= Extinction coefficient (1/m).
k_c	= Velocity profile shape factor (nondimensional).

L_p	= Light path length of beam through smoky environment (m).
\dot{m}_e	= Mass flow rate in exhaust duct (kg/s).
\ddot{m}_e	= $C (\Delta p/T_e)^{1/2}$ mass flow rate, by measurement of pressure drop, in kg/s, in accordance with Eq A5.1.
\dot{m}_e	= $(26.54 \times A \times k_c / f(\text{Re})) \times (\alpha / T_e)^{1/2}$ mass flow rate, by measurement of velocity drop, in kg/s, in accordance with A5.2.
M_a	= Molecular weight of incoming and exhaust air (29 kg/kmol).
M_{CO}	= Molecular weight of carbon monoxide (28 kg/kmol).
M_{CO_2}	= Molecular weight of carbon dioxide (44 kg/kmol).
$M_{\text{H}_2\text{O}}$	= Molecular weight of water (18 kg/kmol).
M_{N_2}	= Molecular weight of nitrogen (28 kg/kmol).
M_{O_2}	= Molecular weight of oxygen (32 kg/kmol).
OD^2	= Optical density (nondimensional).
ΔP	= Pressure drop across the orifice plate or bi-directional probe (in Pa).
$\dot{Q}(t)$	= Heat release rate, as a function of time (in kW).
RSR	= Rate of smoke release (m^2/s).
T_e	= Combustion gas temperature at the orifice plate (K).
T_s	= Combustion gas temperature (near photodetector) (K).
TSR	= Total smoke released (m^2).
\dot{V}_e	= Volumetric flow rate in exhaust duct (at measuring location of mass flow rate) (m^3/s).
\dot{V}_s	= Volumetric flow rate at location of smoke meter (value adjusted for smoke measurement calculations) (m^3/s).
$[x]$	= Concentration of gas x (ppm).
X_{CO}	= Measured mole fraction of CO in exhaust flow (nondimensional).
X_{CO_2}	= Measured mole fraction of CO_2 in exhaust flow (nondimensional).
$X_{\text{H}_2\text{O}}^\circ$	= Measured mole fraction of H_2O in incoming air (nondimensional).
X_{O_2}	= Measured mole fraction of O_2 in exhaust flow (nondimensional).
$X_{\text{O}_2}^\circ$	= Measured mole fraction of O_2 in incoming air (nondimensional).
α	= Combustion expansion factor (non dimensional; normally a value of 1.105).
ρ	= density of air at the temperature in exhaust duct (in kg/m^3).
ρ_{O}	= density of air at 273.15 K (1.293 (kg/m^3)).
ϕ	= oxygen depletion factor (non dimensional).

APPENDIXES
(Nonmandatory Information)
X1. COMMENTARY

X1.1 *Introduction*—This commentary is provided to give some insight into the development of the test method and to describe a rationale for various features used.

X1.2 *Measurements:*

X1.2.1 *Rate of Heat Release:*

X1.2.1.1 The rate of heat release is one of the most important variables, and may be even the single most important variable, in determining the hazard from a fire (7, 18-21). In particular, the rate of heat release is a measure of the intensity of the fire. The rate of heat release and the amount of heat released will determine the extent to which other materials, products, or assemblies in the fire compartment will be ignited and spread the fire further. Thus, an item that releases heat very rapidly (that is, has a high rate of heat release) is more likely to ignite a nearby article than one that has a low rate of heat release. The amount of smoke generated is usually a direct function of the heat release rate.

X1.2.1.2 It is important to point out that the heat released by a product made up of more than one material can often not be predicted from the individual heats released by the individual components. Some recent literature describes heat release by materials (22, 23) and the entire issue of heat release rate (24).

X1.2.1.3 The rate of heat release can be determined by measuring the oxygen concentration in a fire atmosphere (11, 25, 26). Oxygen concentration measurement devices, of the paramagnetic type, are now sufficiently precise to measure the small differences in oxygen concentration needed for determining rate of heat release.

X1.2.2 *Smoke Obscuration:*

X1.2.2.1 The visibility in a fire atmosphere will adversely affect the ability of victims to escape and the ability of fire brigades to fight the fire.

X1.2.2.2 It has been shown that the smoke release measured with a laser beam and with a white light system are equivalent, unless the scanning time is very long (>5 s). This has been determined both in small scale instruments (3, 4) and in full-scale cable tray testing facilities (5, 6).

X1.2.3 *Smoke Toxicity*—The victims of a fire are often overcome by the toxicity of the atmosphere. This is determined by the concentration of smoke (see Terminology E 176) and by the toxicity of its individual components. The overall amount of smoke generated can be measured by means of the mass loss rate, which is equivalent to the rate of smoke generation. The single most important individual toxicant in a fire atmosphere is carbon monoxide, which is present in all fires, together with carbon dioxide and water (27, 28). Some other combustion gases, such as acrolein, hydrogen cyanide, and hydrogen chloride, are also frequently present and may thus also contribute to the toxicity of the fire atmosphere.

X1.3 *Upholstered Furniture*—Fire statistics have shown that a significant proportion of fires start in upholstered

furniture items. It is, therefore of considerable importance to develop a test procedure that can determine the contribution of individual upholstered furniture items to a fire. A recent study investigated the hazards due to furniture fires and the applicability of a full scale test similar to that described here for assessing such fire hazard (29). This standard is a more specific description of the test procedure used for compliance with CA TB 133, but it is generic enough that it can be used in other fashions.

X1.4 *Test Facility:*

X1.4.1 It has been determined that the rate of heat release of upholstered furniture in the standard ASTM room (used in Option A of this test method; 8 by 12 by 8 ft (2.44 by 3.66 by 2.44 m) high) and in the room described in CA TB 133 (used in Option B of this test method; 10 by 12 by 8 ft (3.05 by 3.66 by 2.44 m) high) and in a furniture calorimeter (such as those described in UL 1056 or in Nordtest NT Fire 032), are similar, unless the heat release rate exceeds 600 kW (1). It is of interest that the rate of heat release criterion of CA TB 133 can be met by using a furniture calorimeter or a room of different dimensions than the one specified in the standard. In the United Kingdom, instead of fire testing of full scale upholstered furniture, composites are tested by means of a test of mock-up furniture, BS 5852, Part 2, that places a wood crib on a cushion with a cover and furniture filling.

X1.4.2 It has also been determined that the increase in temperature in the fire room can be represented by the rate of heat release measured in the duct: a rate of heat release of 65 kW is roughly equivalent to an increase in temperature of 111°C (200°F) at a location 25 mm below the ceiling of the CA TB 133 room, directly above the burning item (30).

X1.4.3 In several experimental arrangements, for example, CA TB 133, measurements of gases such as carbon monoxide are customarily done by placing sampling probes in the test room. More recently, it has been recognized that this makes the results apparatus dependent. In other words, if the room dimensions are changed, the same burning item will register different gas concentrations.

X1.4.4 Current practice recommends that combustion gas measurements be made in the exhaust collection duct. If the gases are all collected by the exhaust system and are properly mixed, such instrumentation offers the possibility of a largely apparatus-independent measurement.

X1.4.5 The variable that is fully independent of (reasonable) variations in magnitudes such as room size, room geometry, and duct air flow rate is the gas yield. For any gas x , the yield is computed as shown in Eq A5.15 and Eq A5.16. If the flow rate is constant, the numerator of this equation is simply the product of the mass flow rate and the time period. This gas yield is nondimensional.

X1.4.6 In order to obtain gas yields it is necessary, thus, to measure mass losses, with a load cell, as well as concentrations

of the gas species in question, but requires the measurement of the mass of the burning sample.

X1.4.7 An example of the application of gas yields to fire hazard analysis is found in Ref (30).

X1.5 Ignition Source:

X1.5.1 It has been determined that the ignition source described here, when used at a propane flow rate of 13 L/min, for 80 s, is an adequate (and more reproducible) substitute for the traditional ignition source formerly used in CA TB 133 (five sheets of newspaper, each formed into a loose wad, covered by a sheet metal and wire mesh box and ignited with a match) (2). The January 1991 version of CA TB 133 has relegated the newspaper ignition source to a secondary role as a screening test. There has been no work done to determine the applicability of the square burner defined here under any conditions other than those that mirror the CA TB 133 ignition source.

X1.5.2 The gas burner can, of course, be used at other gas flow rates or for other time periods. However, the range of applicability of such an ignition source has yet to be determined.

X1.6 Limitations:

X1.6.1 This test method is not applicable to ignition by cigarettes or by any other smoldering source.

X1.6.2 The ignition source in this test method is a flaming source and it has been shown that upholstered furniture, particularly in public occupancies, is often involved in fires with flaming ignition sources. Moreover, this ignition source has been shown to be able to distinguish between different kinds of upholstered furniture items. However, it is not known what fraction of actual flaming upholstered furniture fires occur with ignitions more or less intense than the one used here.

X1.6.3 It is not known whether the results of this test method will be equally valid when it is carried out under conditions different from the specified ones. In particular, it is unclear whether the use of a different ignition source, or the same ignition source but with a different duration of flame exposure or with a different gas flow rate, will change the results.

X1.6.4 The value of rate of heat release corresponding to the critical limit between propagating upholstered furniture fires and nonpropagating fires is not known.

X1.6.5 There is not, as yet, a known direct correlation between smoke obscuration or smoke toxicity measurements in the exhaust duct and overall fire hazard.

X2. METHOD OF DETERMINING SUITABILITY OF OXYGEN ANALYZERS FOR MAKING HEAT RELEASE MEASUREMENTS

X2.1 *General*—The type of oxygen analyzer best suited for fire gas analysis is of the paramagnetic type. Electrochemical analyzers or analyzers using zirconia sensors have generally been found not to have adequate sensitivity or suitability for this type of work. The normal range of the instrument to be used is 0 to 25 vol % oxygen. The linearity of paramagnetic analyzers is normally better than can be checked by a user laboratory; thus verifying the linearity is not necessary. It is important, however, to confirm the noise and short-term drift of the instrument used.

X2.2 Procedure:

X2.2.1 Connect two gas bottles having different levels of oxygen approximately two percentage points apart (for example, 15 and 17 vol %, or normal, clean, dry air, and 19 %) to a selector valve at the inlet of the analyzer.

X2.2.2 Connect the electrical power and let the analyzer warm up for up to 24 h with one of the test gases from X2.2.1 flowing through it.

X2.2.3 Connect a data acquisition system to the output of the analyzer. Quickly switch from the first gas bottle to the second bottle, and immediately start collecting data, taking one data point per second. Collect data for 20 min.

X2.2.4 Determine the drift by using a least-squares analysis fitting procedures to pass a straight line through the last 19 min

of data. Extrapolate the line back through the first minute of data. The difference between the readings at 1 min and at 20 min on the fitted straight line represents the short-term drift. Record the drift in units of parts per million of oxygen.

X2.2.5 The noise is represented by the root-mean-square deviation around the fitted straight line. Calculate that root-mean-square value and record it in units of parts per million of oxygen.

X2.2.6 The analyzer is suitable for use in heat release measurements if the sum of the drift plus the noise terms is ≤ 50 ppm oxygen (note that both terms shall be expressed as positive numbers).

X2.3 *Additional Precautions*—A paramagnetic oxygen analyzer is directly sensitive to barometric pressure changes at its outlet port and to flow rate fluctuations in the sample supply stream. It is essential that the flow rate be regulated. Use either a flow rate regulator of the mechanical diaphragm type or an electrical mass flow rate controller. In order to protect against errors due to changes in barometric pressure, one of the following procedures should be used: (a) control the back pressure to the analyzer with a back pressure regulator of the absolute-pressure type or (b) electrically measure the actual pressure at the detector element and provide a signal correction for the analyzer output.



REFERENCES

- (1) Parker, W. J., Tu, K. M., Nurbakhsh, S., and Damant, G. H., "Furniture Flammability: An Investigation of the California Technical Bulletin 133 Test, Part III: Full Scale Chair Burns," *NISTIR 90-4375*, 1990.
- (2) Ohlemiller, T. J., and Villa, K., "Furniture Flammability: An Investigation of the California Technical Bulletin 133 Test, Part II: Characterization of the Ignition Source and a Comparable Gas Burner," *NISTIR 90-4348*, 1990.
- (3) Coaker, A. W., Hirschler, M. M., Shakir, S., and Shoemaker, C. L., "Flammability Testing of New Vinyl Compounds with Low Flammability and Low Smoke Release in Cables," *Proc. 39th Int. Wire and Cable Symposium*, Nov. 13–15, Reno, NV, US Army CECOM, Fort Monmouth, NJ, 1990, pp. 643–654.
- (4) Coaker, A. W., Hirschler, M. M., and Shoemaker, C. L., "Rate of Heat Release Testing for Vinyl Wire and Cable Materials with Reduced Flammability and Smoke: Small Scale and Full Scale Tests," in *Proc. 15th Int. Conf. on Fire Safety, Product Safety Corp.*, San Francisco, CA (USA), Ed. C. J. Hilado, Jan. 8–12, 1990, pp. 220–256.
- (5) Ostman, B., "Comparison of Smoke Release from Building Products," *Int. Conf. Fire, Control the Heat ... Reduce the Hazard*, London, UK, Fire Research Station, UK, Paper 8, Oct. 24–25, 1988.
- (6) Mikkola, E., (VTT, Finland), *First Int. Cone Calorimeter Users' Seminar and Workshop*, London, UK, Jan. 19, 1990.
- (7) Thornton, W., "The Relation of Oxygen to the Heat of Combustion of Organic Compounds," *Philosophical Magazine and J. of Science*, Vol 33, No. 196, 1917.
- (8) Huggett, C., "Estimation of Rate of Heat Release by Means of Oxygen Consumption Measurements, Fire and Materials," Vol 4, 1980, pp. 61–65.
- (9) Parker, W., "An Investigation of the Fire Environment in the ASTM E84 Tunnel Test," *NBS Technical Note 945*, 1977.
- (10) Sensenig, D., "An Oxygen Consumption Technique for Determining the Contribution of Interior Wall Finishes to Room Fires," *NBS Technical Note 1182*, 1980.
- (11) Parker, W., "Calculations of the Heat Release Rate by Oxygen Consumption for Various Applications," *NBSIR 812-2427-1*, 1982.
- (12) Babrauskas, V., "Development of the Cone Calorimeter—A Bench-Scale Rate of Heat Release Apparatus Based on Oxygen Consumption," *NBSIR 82-2611*, 1982.
- (13) Babrauskas, V., Lawson, J., Walton, W., and Twilley, W., "Upholstered Furniture Heat Release Rates Measured with the Furniture Calorimeter," *NBSIR 82-2604*, 1983.
- (14) ASME, "Fluid Meters—Their Theory and Applications," Report of the ASME Committee on Fluid Meters, H. Bean, Editor, Sixth Edition, 1971.
- (15) Ower, E., and Pankhurst, R., "The Measurement of Air Flow," Pergamon Press, 5th Edition, 1977, pp. 112–147.
- (16) McCaffrey, B., and Heskestad, G., *Combustion and Flame*, Vol 26, 1976, pp. 125–127.
- (17) Janssens, M. L., "Measuring Rate of Heat Release by Oxygen Consumption," *Fire Technology*, 27, 1991, pp. 234–249.
- (18) Thomas, P. H., in "Int. Conf. Fire: Control the Heat ... Reduce the Hazard," London, UK, QMC Fire and Materials Centre, Paper 1, Oct. 24–25, 1988.
- (19) Babrauskas, V., in "Int. Conf. Fire: Control the Heat ... Reduce the Hazard," London, UK, QMC Fire and Materials Centre, Paper 4, Oct. 24–25, pp. 67–80, 1988.
- (20) Babrauskas, V., and Peacock, R. D., "Heat Release Rate. The Single Most Important Variable in Fire Hazard," in *Fire Retardant Chemicals Association 1990 Fall Technical Meeting*, Pontevedra Beach, FL, October 22–24, 1990.
- (21) Hirschler, M. M., "How to Measure Smoke Obscuration in a Manner Relevant to Fire Hazard Assessment: Use of Heat Release Calorimetry Test Equipment," *J. Fire Sciences*, 9, 1991, pp. 183–222.
- (22) Tran, H., "Experimental Data on Wood Materials," Chapter 11 b, in *Heat Release in Fires*, Elsevier, London, UK, V. Babrauskas and S. J. Grayson, Eds., pp. 357–372, 1992.
- (23) Hirschler, M. M., "Heat Release from Plastics," Chapter 12 a, in *Heat Release in Fires*, Elsevier, London, UK, V. Babrauskas and S. J. Grayson, Eds., pp. 375–422, 1992.
- (24) Babrauskas, V., and Grayson, S. J., Editors, "Heat Release in Fires," Elsevier, London, UK, 1992.
- (25) Huggett, C., "Estimation of Rate of Heat Release by Means of Oxygen Consumption Measurements, Fire and Materials," Vol 4, 1980, pp. 61–65.
- (26) Parker, W. J., "Calculations of the Heat Release Rate by Oxygen Consumption for Various Applications," *Journal of Fire Sciences*, Vol 2, September/October, 1984, pp. 380–395.
- (27) Hirschler, M. M., "General Principles of Fire Hazard and the Role of Smoke Toxicity," in *Fire and Polymers: Hazards Identification and Prevention* (Ed. G. L. Nelson), *ACS Symposium Series 425*, Developed from Symp. at 197th ACS Mtg, Dallas, TX, April 9–14, 1989, Amer. Chem. Soc., Washington, DC, Chapter 28, 1990, pp. 462–478.
- (28) Debanne, S. M., Hirschler, M. M., and Nelson, G. L., "The Importance of Carbon Monoxide in the Toxicity of Fire Atmospheres," San Antonio, TX, "Fire Hazard and Fire Risk Assessment," *ASTM STP 1150*, ASTM, Philadelphia, PA, M. M. Hirschler, Ed., pp. 9–23.
- (29) Quintiere, J. G., "Furniture Flammability: An Investigation of the California Technical Bulletin 133 Test. Part I: Measuring the Hazards of Furniture," *NISTIR 90-4360*, 1990.
- (30) Babrauskas, V., Harris, R. H., Braun, E., Levin, B. C., Paabo, M., and Gann, R. G., "The Role of Bench-Scale Data in Assessing Real-Scale Fire Toxicity," *NIST Tech. Note No. 1284*, National Inst. Standards Technology, Gaithersburg, MD, 1991.

ASTM International takes no position respecting the validity of any patent rights asserted in connection with any item mentioned in this standard. Users of this standard are expressly advised that determination of the validity of any such patent rights, and the risk of infringement of such rights, are entirely their own responsibility.

This standard is subject to revision at any time by the responsible technical committee and must be reviewed every five years and if not revised, either reapproved or withdrawn. Your comments are invited either for revision of this standard or for additional standards and should be addressed to ASTM International Headquarters. Your comments will receive careful consideration at a meeting of the responsible technical committee, which you may attend. If you feel that your comments have not received a fair hearing you should make your views known to the ASTM Committee on Standards, at the address shown below.

This standard is copyrighted by ASTM International, 100 Barr Harbor Drive, PO Box C700, West Conshohocken, PA 19428-2959, United States. Individual reprints (single or multiple copies) of this standard may be obtained by contacting ASTM at the above address or at 610-832-9585 (phone), 610-832-9555 (fax), or service@astm.org (e-mail); or through the ASTM website (www.astm.org).