



# Standard Test Method for Contamination Outgassing Characteristics of Spacecraft Materials<sup>1</sup>

This standard is issued under the fixed designation E 1559; the number immediately following the designation indicates the year of original adoption or, in the case of revision, the year of last revision. A number in parentheses indicates the year of last reapproval. A superscript epsilon ( $\epsilon$ ) indicates an editorial change since the last revision or reapproval.

## 1. Scope

1.1 This test method covers a technique for generating data to characterize the kinetics of the release of outgassing products from materials. This technique will determine both the total mass flux evolved by a material when exposed to a vacuum environment and the deposition of this flux on surfaces held at various specified temperatures.

1.2 This test method describes the test apparatus and related operating procedures for evaluating the total mass flux that is evolved from a material being subjected to temperatures that are between 298 and 398K. Pressures external to the sample effusion cell are less than  $7 \times 10^{-3}$  Pa ( $5 \times 10^{-5}$  torr). Deposition rates are measured during material outgassing tests. A test procedure for collecting data and a test method for processing and presenting the collected data are included.

1.3 This test method can be used to produce the data necessary to support mathematical models used for the prediction of molecular contaminant generation, migration, and deposition.

1.4 All types of organic, polymeric, and inorganic materials can be tested. These include polymer potting compounds, foams, elastomers, films, tapes, insulations, shrink tubing, adhesives, coatings, fabrics, tie cords, and lubricants.

1.5 There are two test methods in this standard. Test Method A uses standardized specimen and collector temperatures. Test Method B allows the flexibility of user-specified specimen and collector temperatures, material and test geometry, and user-specified QCMs.

1.6 The values stated in SI units are to be regarded as the standard.

1.7 *This standard does not purport to address all of the safety concerns, if any, associated with its use. It is the responsibility of the user of this standard to establish appropriate safety and health practices and determine the applicability of regulatory limitations prior to use.*

## 2. Referenced Documents

### 2.1 ASTM Standards:

E 177 Practice for Use of the Terms Precision and Bias in ASTM Test Methods<sup>2</sup>

E 595 Test Method for Total Mass Loss and Collected Volatile Condensable Materials from Outgassing in a Vacuum Environment<sup>3</sup>

IEEE/ASTM SI 10 American National Standard for Use of the International System of Units (SI): The Modern Metric System<sup>2</sup>

### 2.2 Military Standard:

MIL-P-27401C Propellant Pressurizing Agent, Nitrogen<sup>4</sup>

## 3. Terminology

### 3.1 Definitions:

3.1.1 *AT cut crystal, n*—a quartz crystal orientation that minimizes the temperature coefficient (frequency change versus temperature) over a wide range of temperature.

3.1.2 *collected volatile condensable material, CVCM, n*—(from Test Method E 595). The quantity of outgassed matter from a test specimen that condenses on a collector maintained at a specific constant temperature for a specified time and measured before and after the test outside the chamber.

3.1.2.1 *Discussion*—CVCM is specific to Test Method E 595 and is calculated from the condensate mass determined from the difference in mass of the collector plate before and after the test in a controlled laboratory environment. CVCM is expressed as a percentage of the initial specimen mass. The view factor is not considered; so all the VCM outgassing from the sample may not be collected. Care should be used in comparing the CVCM from Test Method E 595 with VCM from this test method.

3.1.3 *differential scanning calorimetry, DSC, n*—a technique in which the difference in energy inputs into a substance

<sup>1</sup> This test method is under the jurisdiction of ASTM Committee E21 on Space Simulation and Applications of Space Technology and is the direct responsibility of Subcommittee E21.05 on Contamination.

Current edition approved May 10, 2003. Published June 2003. Originally approved in 1993. Last previous edition approved in 2000 as E 1559 – 00.

<sup>2</sup> *Annual Book of ASTM Standards*, Vol 14.02.

<sup>3</sup> *Annual Book of ASTM Standards*, Vol 15.03.

<sup>4</sup> Available from Standardization Documents Order Desk, Bldg. 4 Section D, 700 Robbins Ave., Philadelphia, PA 19111-5094, Attn: NPODS.

and a reference material is measured as a function of temperature while the substance and reference material are subjected to a controlled-temperature program.

3.1.4 *effusion cell, n*—a container, placed in a vacuum, in which a sample of material can be placed and heated to some specified temperature.

3.1.4.1 *Discussion*—The container has a cylindrical orifice at one end so that evolving gases exit the cell in a controlled manner. The effusion cell dimensions and orifice size are specified such that there is free molecular flow of the evolving gasses and a predictable molecular flux from the orifice.

3.1.5 *mass flux, n*—the mass of molecular flux.

3.1.6 *molecular flux (molecules·cm<sup>-2</sup>·s<sup>-1</sup>), n*—the number of gas molecules crossing a specified plane in unit time per unit area.

3.1.7 *nonvolatile residue, NVR, n*—the quantity of residual molecular and particulate matter remaining following the filtration of a solvent containing contaminants and evaporation of the solvent at a specified temperature.

3.1.8 *outgassing, n*—the evolution of gas from a material, usually in a vacuum. Outgassing also occurs in a higher pressure environment.

3.1.9 *quartz crystal microbalance, QCM, n*—a device for measuring small quantities of mass using the properties of a quartz crystal oscillator.

3.1.9.1 *Discussion*—The resonant frequency of a quartz crystal oscillator is inversely proportional to the thickness of the crystal. When the mass of a uniform deposit is small relative to the mass of the crystal, the change in frequency is proportional to the mass of the deposit.

3.1.10 *QCM thermogravimetric analysis, QTGA, n*—a technique in which a QCM is heated at a constant rate to remove a collected deposit.

3.1.10.1 *Discussion*—This is performed to determine the evaporation characteristics of the species in the deposit. The mass of the deposit on the QCM is recorded as a function of time or temperature.

3.1.11 *residual gas analyzer, RGA, n*—a mass spectrometer mounted inside or attached to a vacuum chamber.

3.1.11.1 *Discussion*—RGA can be used for identifying gases in the vacuum chamber.

3.1.12 *total mass flux (g·cm<sup>-2</sup>·s<sup>-1</sup>), n*—the summation of the mass from all molecular species crossing a specified plane in unit time per unit area.

3.1.13 *total mass loss, TML, n*—total mass of material outgassed from a test specimen that is maintained at a specified constant temperature and operating pressure for a specified time and measured within the test chamber. TML is expressed as a percentage of the initial specimen mass. In addition, TML can be normalized with respect to the sample surface area and be expressed as µg/cm<sup>2</sup>.

3.1.13.1 *in-situ TML, n*—calculated from the mass deposited on a cryogenically cooled QCM and the view factor from the effusion cell orifice to the QCM.

3.1.13.2 *Discussion*—In-situ TML is a function of the outgassing test time and is expressed as a percentage of the initial specimen mass. This is not necessarily the same as the TML determined by Test Method E 595.

3.1.13.3 *ex-situ TML, n*—total mass of material outgassed from a test specimen that is maintained at a specified constant temperature and operating pressure for a specified time and measured outside the test chamber.

3.1.13.4 *Discussion*—Ex-situ TML is calculated from the mass of the specimen as measured before and after the test in a controlled laboratory environment and is expressed as a percentage of the initial specimen mass. (From Test Method E 595.)

3.1.14 *total outgassing rate, n*—the net rate of mass loss from a material sample as a result of outgassing. Total outgassing rate can be normalized per unit sample surface area and expressed as g·cm<sup>-2</sup>·s<sup>-1</sup> or it can be normalized per unit initial sample mass and expressed as g·g<sup>-1</sup>·s<sup>-1</sup>.

3.1.15 *volatile condensable material, VCM, n*—the matter that outgasses from a material and condenses on a collector surface that is at a specified temperature.

3.1.15.1 *Discussion*—For this test method, this is the quantity of outgassed matter from a test specimen that condenses on surfaces maintained at QT2 or QT3. The VCM is calculated from the mass deposited on QCM2 or QCM3 and the view factor from the effusion cell orifice to the QCMs. VCM is a function of the outgassing test time and is expressed as a percentage of the initial specimen mass. In addition, VCM can be normalized with respect to the sample surface area and be expressed as µg/cm<sup>2</sup>. This is not the same as CVCM as determined by Test Method E 595 (see 3.1.2).

3.2 *Acronyms: Acronyms:*

3.2.1 *GN<sub>2</sub>, n*—gaseous nitrogen.

3.2.2 *LN<sub>2</sub>, n*—liquid nitrogen.

3.2.3 *MAPTIS, n*—Materials and Process Technical Information Service.

3.3 *Definitions of Terms Specific to This Standard:*

3.3.1 *QCM1*—the QCM that is operating at the temperature TQ1 (cryogenic) for measuring the total outgassing rate.

3.3.2 *QCM2 and QCM3*—the QCMs that are operating at temperatures TQ2 and TQ3 for the measurement of the deposition of outgassing matter.

## 4. Summary of Test Method

4.1 The test apparatus described in this test method is designed to measure outgassing rate data that can be used to develop kinetic expressions for use in models that predict the evolution of molecular contaminants and the migration and deposition of these contaminants on spacecraft surfaces. Materials that contain volatile species that will be outgassed under the temperature and vacuum conditions of this test method can be characterized. The quartz crystal microbalances used in this test method provide a sensitive technique for measuring very small quantities of deposited mass. In addition to providing data for kinetic expressions, the reduced data can be used to compare the outgassing behavior of different materials for material selection purposes.

4.2 There are two test methods in this standard. Test Method A is the standard procedure using prescribed configurations and temperatures. Test Method B allows for the use of spacecraft system specific temperatures, configurations, and QCM collector surface finishes.

4.3 The measurements are made by placing the material sample in an effusion cell so that the outgassing flux leaving the cell orifice will impinge on three QCMs which are arranged to view the orifice. A fourth QCM is optional. The effusion cell is held at a constant temperature in the high vacuum chamber and has a small orifice directed at the QCMs. The QCMs are controlled to selected temperatures. The total outgassing rate is determined from the collection rate on a cryocooled QCM. At the end of the isothermal test, the QCMs are heated in a controlled manner to determine the evaporation characteristics of the deposits.

4.4 The effusion cell is loaded from the vacuum interlock chamber to the main test chamber and is positioned at a fixed distance and angle with respect to the QCM surfaces. The effusion cell is temperature controlled to provide constant and uniform heating of the sample. The vacuum interlock chamber is a device that enables the expedient introduction of the test sample into the high vacuum of the main test chamber. Use of the interlock chamber to load and unload samples prevents loss of vacuum in the main chamber and diminishes the need to pump it down before each test.

4.5 The QCM collection method for measuring the total outgassing rate from a sample is an indirect technique. Rather than directly measuring sample mass loss, the basic measurement is the fraction of the flux that condenses on the cryogenically cooled QCM collector at a point in the outgassing flow field. That point in the flow field is defined as the geometric location of the QCM relative to the effusion cell orifice, which is at a fixed location. To determine the rate of sample mass loss from the rate of QCM collection, the view factor from the QCM to the effusion cell orifice and the angular distribution of flux leaving the orifice must be determined. This relationship can be calculated from the apparatus geometry and the effusion cell orifice dimensions.

4.6 A QCM thermogravimetric analysis (QTGA) test is also included in the procedure. This technique heats the QCMs at a constant rate to measure evaporation characteristics of the deposits collected on the QCMs. The QTGA also provides an effective means to clean the QCM surfaces before subsequent tests.

4.7 It is critical to the posttest analysis that the material sample be completely described and specified, so that the outgassing characteristics can be applied to the material when used on a spacecraft. It is also necessary so that any material sample can be properly compared with that of other samples. The outgassing rate of the material will, in general, be determined by its composition, processing history, and environmental conditioning before the test. All test sample processing should be representative of normal material processing and usage. All materials are environmentally conditioned to specified conditions. However, samples may be subjected to environmental conditions that are expected during actual use. Test sample processing and conditioning history shall be included in the test report.

4.8 Because outgassing of all materials is, to some extent, diffusion rate controlled, the outgassing rate of a test sample depends on the distance from the sample interior to a free surface. Hence, the geometry of a test sample must be

controlled in a specified manner to permit meaningful interpretation of the data. When possible, the sample geometry should be in the specified configuration to simplify modeling. However, the material sample can be made with the same geometry as it would have in an actual application.

## 5.

## 6. Test Apparatus

6.1 *Description*—The test apparatus consists of four main subsystems: a vacuum chamber, a temperature control system, internal configuration, and a data acquisition system. Fig. 1 is a schematic of the systems, and Fig. 2 shows the vacuum chamber and internal configuration.

6.2 *Vacuum Chamber*—The principal components of the vacuum chamber are the main test chamber, the vacuum interlock chamber, and cryogenic shrouds (for example,  $LN_2$ ). A high-vacuum gate valve is used to isolate the main test chamber from the interlock chamber. This allows the effusion cell to be withdrawn or inserted into the main chamber without the loss of high vacuum in the main chamber. High-vacuum electrical and mechanical feedthroughs are used to access the interior of the chamber.

6.3 *Internal Configuration*—Three quartz crystal microbalances (QCMs) (a fourth QCM is optional), an effusion cell, and cryogenic heat sinks in the chamber are the principal components. The cryogenic heat sinks are used to ground the QCMs thermally and to cool shrouds which surround the effusion cell and QCMs. The cold shrouds limit molecular contaminant fluxes to the line-of-sight outgassing flux from the effusion cell orifice to the collector QCMs. The cryogenic heat sink system ( $LN_2$  reservoirs) and shrouds, effusion cell, and QCMs are shown in Fig. 2.

6.3.1 The QCMs are thermally shielded from each other so that the temperatures of each can be controlled independently. Each QCM has its own temperature sensing and control system.

6.3.2 Each QCM contains two crystals (one for mass collection and one for reference), the oscillator electronics, and a temperature sensor. The QCM crystals shall have optically polished surfaces (60/40 cerium polish). Uncoated, aluminum electrodes shall be used for the sensing and reference crystals.

NOTE 1—The quantitative effect of the surface finish on the deposition rates is not known at this time. A diffuse surface has more surface area than a polished surface resulting in more conservative (higher) values of contaminant accumulation, especially with monolayer thicknesses. However, diffuse surfaces are difficult to reproduce and clean uniformly, resulting in unwanted test variability. Future round-robin tests will be used to evaluate the effects of surface finish on the results.

NOTE 2—Aluminum electrodes are easy to apply and to clean. If it is desirable to measure deposition on a simulated optical surface, a QCM that simulates the surface roughness and composition of the optical surfaces may be used in Test Method B. Future round-robin tests will be used to evaluate the effects of surface composition on the results.

6.3.3 The QCMs are thermally connected to a cryogenic heat sink (that is,  $LN_2$ ), and heaters provide the temperature control above the base temperature ( $\leq 90K$ ). The QCMs shall be controllable from the set points specified in 10.3 or 10.4 to 398K and maintained to within  $\pm 0.5K$  of the desired temperature.

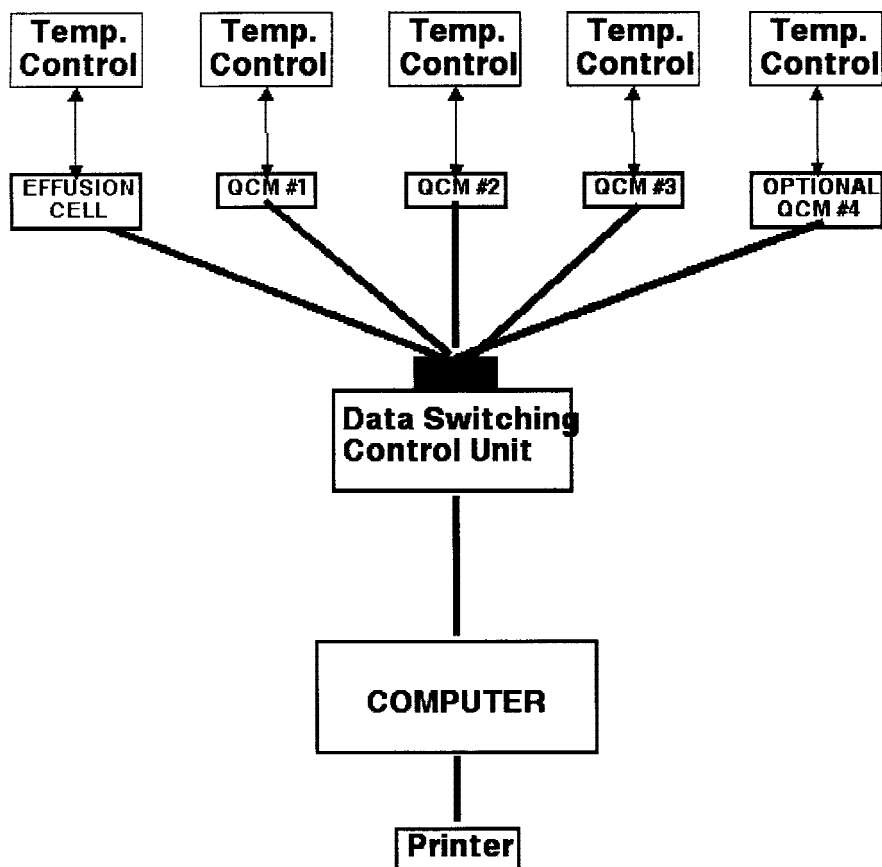

FIG. 1 Data System and Control Schematic

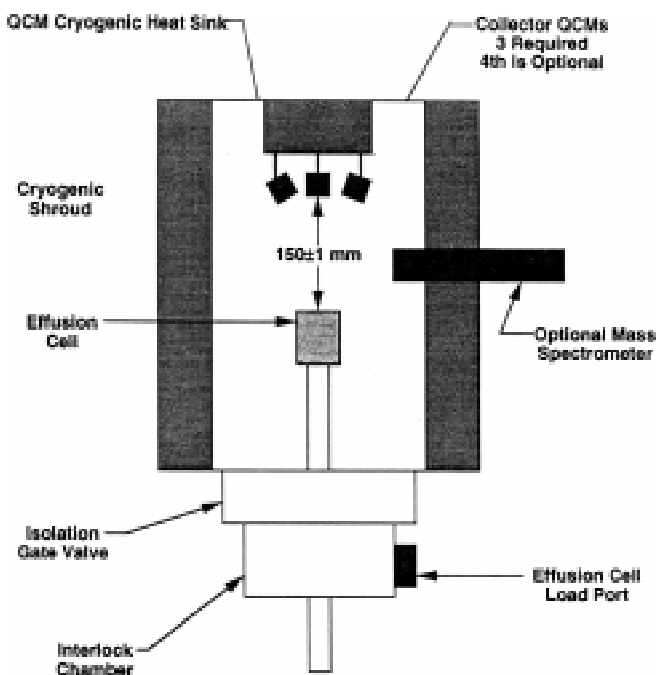

FIG. 2 Test Chamber

6.3.4 The required sensitivity of the QCM to mass deposits depends upon the required precision of the mass measurements. Sensitivity is a function of the crystal cut, temperature, and natural frequency of the quartz crystals. QCMs used for

this test method shall have a sensitivity of at least  $1 \times 10^{-8} \text{ g}\cdot\text{cm}^{-2}\cdot\text{Hz}^{-1}$  at 298K. Table 1 shows the theoretical sensitivities of quartz crystals.<sup>5</sup> The sensitivity of the QCMs shall be sufficient to measure the incident mass fluxes required to perform the test.

NOTE 3—QCMs with 10- or 15-MHz crystals are typically used. The sensitivities in Table 1 assume that the areas of the electrodes on both sides of a crystal are the same.

6.3.5 The QCMs are arranged symmetrically so that each QCM has the same view factor to the effusion cell orifice. The QCMs are angled  $10 \pm 0.5^\circ$  off the normal to the plane of the effusion cell orifice so that the axes of the QCMs intersect at a common point that coincides with the location of the effusion cell orifice when the cell is placed in its standard position. The distance from the effusion cell orifice to each QCM collector surface is  $150 \pm 1 \text{ mm}$ .

<sup>5</sup> Wrought aluminum alloys such as the 2000 and 6000 series can be used.

TABLE 1 AT or Rotated Cut Crystal with Identical Electrode Areas on Each Side of the Crystal

Natural Frequency ( <i>f</i> ), MHz	Sensitivity at 298K ( <i>K<sub>s</sub></i> ), $\text{g}\cdot\text{cm}^{-2}\cdot\text{Hz}^{-1}$
10	$4.42 \times 10^{-9}$
15	$1.96 \times 10^{-9}$
20	$1.10 \times 10^{-9}$

NOTE 4—This QCM to collector surface geometry is mandated for Test Method A. See 10.1 for Test Method B, allowing nonstandard geometries and test conditions.

NOTE 5—The QCMs shall be placed so that the active surface of any QCM cannot “see” the active surface of any other QCM.

6.3.6 The effusion cell is cylindrical and the recommended dimensions are  $65 \pm 5$ -mm inside diameter by  $50 \pm 5$  mm in depth. Effusion cell dimensions shall accommodate the standard sample geometries described in Section 9. The flux distribution of the outgassing products leaving the effusion cell is controlled by the cylindrical orifice in the top of the effusion cell. The orifice size shall be  $3.0 \pm 0.1$ -mm diameter by  $3.0 \pm 0.1$ -mm long.

NOTE 6—This orifice size is mandated for conformance to this test method.

6.3.7 The cell shall be machined from aluminum<sup>5</sup> or copper<sup>6</sup> for high thermal conductivity. The cell shall have an integral heater and temperature sensor. The integral heater shall be capable of uniformly heating the effusion cell to 398K within 20 min after inserting the cell into the main vacuum chamber.

6.3.8 Effusion cell temperatures shall be controlled to within  $\pm 0.5$ K.

6.3.9 The positioning mechanism shall place the exit plane of the effusion cell orifice at a distance of  $150 \pm 1$  mm from the surface of the sensing crystal in each QCM.

6.3.10 A shroud, cooled with a cryogenic heat sink, shall surround the effusion cell to minimize the reflection of molecular flux from the chamber wall to the QCMs. A shutter may be used over the orifice to isolate the QCMs from the molecular flux.

6.4 *Temperature Control System*—All temperatures of the effusion cell and the QCMs are maintained by independently controlled heaters to a precision of  $\pm 0.5$ K or better. In addition to maintaining temperatures at selected specific values, the controller for the QCMs shall be capable of performing ramp functions, in which temperatures are increased at a constant rate of 1K per minute.

NOTE 7—Users should be aware that the QTGA heating rate can affect the test data. A heating rate of 1K per minute was selected for practicality. 1K per minute was found to provide good agreement with the predicted evaporation rates of water using vapor pressure data. Higher rates showed significant errors. This is covered in Footnote 7.<sup>7</sup> Lower rates have also shown differences but will result in long, impractical test times.

6.5 *Data Acquisition System*—Data acquisition, storage, and manipulation can be accomplished by any method that is capable of measuring the frequencies of the QCMs, the temperatures of the QCMs and the effusion cell, and the times of data collection at specified intervals. Experimental or processed data shall be stored for later retrieval for further analysis. An automated, computer operated data collection system is recommended.

<sup>6</sup> OFHC (oxygen free, high conductivity) copper has been found to be satisfactory.

<sup>7</sup> Glassford, A. P. M., Lockheed Palo Alto Research Laboratory, “Analysis of the Accuracy of a Commercial Quartz Crystal Microbalance,” *Thermophysics of Spacecraft and Outer Planet Probes, AIAA Progress in Astronautics & Aeronautics*, Vol 56, A. M. Smith, Ed., 1977, pp. 175–196.

## 7. Support Equipment/Materials

7.1 *Analytical Microbalance*, with a 30 g or greater tare, a readability of 10  $\mu$ g or better, and a precision of  $\pm 10$   $\mu$ g is required for recording mass changes of the samples.<sup>8</sup>

7.2 *Oil-Free Aluminum Foil*<sup>9</sup>, is recommended as a non-outgassing substrate.

7.3 *High Purity, Low NVR Solvents* are required for cleaning the effusion cell and other hardware before insertion into the vacuum chamber. Suitable reagent grade solvents include acetone, methanol, ethanol, 1,1,1 trichloroethane (methyl chloroform), and 75/25 % mixture of methyl chloroform and ethanol.

7.3.1 Low NVR hexane or toluene is required to clean QCM surfaces.

NOTE 8—Some QCMs may use materials on the electrodes that are not compatible with some solvents. Cleaning instructions from the QCM manufacturer should be followed.

7.3.2 Swabs shall be extracted to have a low NVR.<sup>10</sup>

7.3.3 Gloves shall be powder-free latex or polyethylene.<sup>11</sup>

7.4 An accurate micrometer is required to measure sample dimensions. Dimensions shall be determined to an accuracy of  $\pm 1$  % of the dimension.

## 8. Hardware Cleaning

NOTE 9—The following guidelines should be followed upon the removal of the QCMs.

8.1 *Vacuum System*:

8.1.1 Clean in accordance with good vacuum practices before assembly.

8.1.2 Metal components may be chemically cleaned using procedures appropriate to the material.

8.1.3 Some residual contamination may be removed using toluene, methyl ethyl ketone, or acetone. Perform a final rinse with a low NVR solvent (see 7.3).

NOTE 10—Cleaning with solvents may be hazardous. All procedures should be reviewed for conformance to local safety requirements.

NOTE 11—The background accumulation on the QCMs shall fall within the rates in 10.3.2. To meet these rates it may be necessary to bakeout the chamber in vacuum at temperatures up to 125°C. This should be performed without the QCMs or any other equipment installed that cannot tolerate the temperature.

8.2 *QCMs*:

8.2.1 Carefully rinse the QCM crystals with clean solvent as specified in 7.3.1 so as not to damage the electrode surfaces.

NOTE 12—Some electrodes are extremely delicate (such as gold), and care should be taken to prevent damage.

8.2.2 Extracted, seedless cotton balls or low NVR swabs<sup>12</sup> may be used to wipe the crystal surfaces gently to remove stubborn deposits.

<sup>8</sup> Sartorius Model 2405 microbalance, Sartorius Model 2434 Semi-micro, or equivalent.

<sup>9</sup> Fed Spec Food Service Grade aluminum foil, oil free, Federal Stock No. 8135-00-724-0551 has been found to be satisfactory.

<sup>10</sup> Commercial swabs may be acceptable but should be tested before use for NVR and suitability for this application.

<sup>11</sup> Powder-free latex gloves are available commercially. Commercial gloves should be tested for suitability before use.

<sup>12</sup> Commercial swabs may be acceptable but should be tested before use for NVR and suitability for this application.

NOTE 13—Soft electrode surfaces, such as gold, should be rinsed with the appropriate solvents and then cleaned using a vacuum bakeout. Mechanical cleaning, if required, must be done with great care.

8.2.3 If seedless cotton balls are used, they may be extracted using a low NVR solvent in an ultrasonic bath or by Soxhlet extraction. If an ultrasonic bath is used, at least two extraction cycles shall be used. Each cycle shall use clean solvent.

8.2.4 *QCM Sensor Housing*—Cleaning of the sensor housing shall follow good vacuum equipment practices and be compatible with the housing materials.

## 9. Test Specimen Specification

9.1 Outgassing kinetics depend upon the thickness of the material and the surface area exposed to vacuum. The geometry of a material test sample shall be representative of the application geometry for that material or selected such that the outgassing rates for other geometries can be inferred from the outgassing rate data measured for the test sample. The test sample geometry that satisfies this requirement depends on the physical processes involved in outgassing for the specific test material.

9.2 The dimensions of the sample and its holder or substrate, where applicable, shall be controlled, measured, and documented. Sample dimensions shall be measured to an accuracy of  $\pm 1\%$ . Sample surface area and volume are critical to data analysis. Fiber volume and inert filler composition shall be reported when applicable.

9.3 The sample mass can range from 0.5 to 10 g not including substrate. The specimen mass is determined by the quantity of outgassed deposits that can be measured accurately. This requirement is determined by apparatus measurement sensitivity limitations. The upper limit of specimen mass is determined by the saturation of the QCM when the mass of deposit becomes too large. With saturation, the circuit stops oscillating. In addition, when the deposit of the QCM is a liquid, the frequency change versus mass becomes nonlinear as the deposit becomes thicker.

9.4 The mass of the test sample and its holder or substrate, where applicable, shall be controlled, measured, and documented. Test sample mass shall be measured on a microbalance to an accuracy of  $\pm 10\ \mu\text{g}$ .

9.5 The identity and the procurement, acceptance, and application specifications of the material used for the test sample shall be documented. Identification markings shall not be applied to the sample. A separate ID tag that is removed during the test shall be used. The traceability of a particular material sample shall be achieved by specifying the supplier lot or batch number or both.

9.6 Unless special handling is specified, all samples shall be preconditioned before test by holding them at 296K (23°C) in a 50 % relative humidity environment for at least 24 h. This preconditioning procedure is the same as that specified in Test Method E 595.

9.7 It is suggested that materials such as laminates, adhesives, potting compounds, paints, and coatings that are typically “cured” in some fashion be screened for degree of cure before use in this test. The “degree of cure” for a sample can be performed in a differential scanning calorimetry (DSC) test apparatus that is commonly available in analytical chemistry

labs. Materials that are not in a fully cured state can be expected to outgas more than one that is fully cured. Phase changes in these materials might occur during heating and could affect temperature measurements in the effusion cell.

NOTE 14—It is desirable for the specimen to be in good thermal contact with the effusion cell. However, this is affected by the shape and size of the specimen.

9.8 *Adhesives and Sealants*—Castable adhesives and sealants shall be cast and cured in a 10-mm-diameter by 25-mm-long tube. The tube shall be made of a nonoutgassing material. Film, paste, filled, and supported adhesives shall be cured between two nonoutgassing plates, such as aluminum foil (see 7.2). Uniform edge thickness shall be maintained with dams, shim, or clamps which are removed for the test. The sample dimensions shall be 1 mm thick by 40 mm square. The exposed adhesive surface area shall be measured.

9.9 *Cable Insulation and Shrink Tubing*—Cable insulation and shrink tubing shall be tested in the as-supplied geometry.

9.10 *Conformal Coatings*—Conformal coatings shall be applied to a nonoutgassing substrate, such as aluminum foil (see 7.2). Cut the substrate into sections of small enough area to stack in the effusion cell. Do not pack tightly so that outgassing rates from the coating surfaces are constrained by venting geometry.

9.11 *Electrical Components*—Electrical components shall be tested in the as-supplied geometry.

9.12 *Electrical Shields*—Electrical shields shall be tested in the as-supplied geometry.

9.13 *Films and Sheet Materials*—Films and sheet materials shall be tested in the as-supplied geometry. (Adhesive films shall be cured and used as in 9.8.)

9.14 *Foams*—Foams supplied as sheet stock shall be tested in the as-supplied thicknesses. Sample dimensions shall be selected so as to have a surface area to volume that is representative of the application and to minimize edge effects. Foams supplied as castable curing materials shall be tested in accordance with 9.8. Excess cured foam shall be trimmed from the top of the tube.

9.15 *Grease, Lubricants, and Liquids*—Grease, lubricants, and liquids shall be placed in a 25-mm-diameter, nonoutgassing (for example, aluminum) dish-type holder, to a depth of approximately 3 mm. The dish-type holder is then placed in the effusion cell. The holder shall maintain a constant exposed liquid surface area during the evaporation process.

9.16 *Lacing Tape and Cord Cable Ties*—Lacing tape and cord cable ties shall be tested in the as-supplied geometry.

9.17 *Laminates and Circuit Boards*—Laminates and circuit boards shall be tested in the as-supplied geometry. A sample size of approximately 40 by 40 mm is acceptable. The presence and orientation of reinforcements affects diffusion rates. Outgassing from resin-rich surfaces predominates during the initial period. Then, diffusion may occur parallel to fiber paths; thus, laminate edge effects may be important, especially in thick samples. Distance to a free surface is an important consideration. If anisotropy exists, prepare a special sample holder to constrain the outgassing flow appropriately.

9.18 *Paint, Ink, Lacquers, and Varnishes*—Paint, lacquers, varnishes, and similar coatings shall be applied to a nonoutgassing substrate, for example, aluminum foil (see 7.2). Cut the substrate into sections small enough to stack in the effusion cell. Do not pack tightly so that diffusion between layers affects the results.

9.19 *Potting Compounds*—Potting compounds shall be cast in accordance with 9.8 to constrain the internal diffusion flow to the surface to one dimension.

9.20 *Premolded Rubbers, Elastomers, and Molding Compounds*—Rubbers, elastomers, and molding compounds shall be tested in the as-received geometry. Sample surface area to volume and edge effects shall be considered when preparing samples.

9.21 *Tapes*—Tapes shall be applied to a nonoutgassing substrate; for example, aluminum foil. Samples shall be approximately 1 m long and 50 mm wide, coiled or folded to fit into the effusion cell. This allows the outgassing from the ends to be negligible compared to outgassing perpendicular to the length and provides sufficient material for analysis.

## 10. Procedure

10.1 There are two versions of the test method. Test Method A uses standard source temperatures (temperature of the effusion cell), three QCMs with polished crystal surfaces, at standard temperatures. Test Method B allows the use of spacecraft-system-specific temperatures and configurations. Items of deviation under Test Method B include the following: possible incorporation of a fourth QCM, nonstandard effusion cell, nonstandard QCM temperatures, nonstandard QCM to effusion cell distance, QCMs containing crystals with different crystal surfaces, and the use of a mass spectrometer. All data reported for measurements using Test Method B shall state deviations from Test Method A. For nonstandard QCM to effusion cell distance, report test geometry and view factor calculations.

10.1.1 Clean the test chamber components before assembly in accordance with Section 8.

### 10.2 Test Chamber Preparation:

NOTE 15—The following three steps are only required for a new chamber or when major repairs are performed on the chamber.

10.2.1 Clean the test chamber before assembly in accordance with 8.1 to remove all residual molecular and particulate contamination resulting from the manufacturing processes.

10.2.2 Clean the QCMs using the procedure in 8.2 if there are visible contaminants on the surfaces of the crystals or if bench tests show evidence of contamination.

10.2.3 Install the QCMs and other equipment.

10.2.4 Clean the effusion cell in accordance with 8.1.

10.2.5 Close the isolation gate valve between the interlock and main chambers if it is not already closed.

10.2.6 Place the empty effusion cell in the interlock chamber.

10.2.7 Replace the effusion cell load port cover.

10.2.8 Evacuate the interlock chamber to  $7 \times 10^{-3}$  Pa ( $5 \times 10^{-5}$  torr) or less.

10.2.9 Heat the effusion cell to 398K and continue for a minimum of 12 h. Allow the cell to cool to ambient temperature.

10.2.10 Evacuate the main chamber to  $7 \times 10^{-3}$  Pa ( $5 \times 10^{-5}$  torr) or less if it is not already under vacuum.

NOTE 16—At this pressure, the mean free path is long enough, approximately 100 cm, so that the molecular flux transport is not affected. However, high partial pressures of condensable gases will affect the stability of the QCMs. Section 10.3.2 specifies the conditions for the stability of the QCMs.

10.2.11 Activate the cryocooling and allow the QCMs and shrouds to cool if they are not already at the base heat sink temperature.

10.2.12 Clean all QCMs by heating them to 398K and maintain at this temperature until the QCM frequency becomes stable. This may be performed in parallel with 10.2.4-10.2.9. Allow the QCMs to cool to normal operating temperatures. This step, 10.2.12, may be skipped if the QTGA test of 10.5 has been just performed.

10.2.13 Run the Test Method A or Test Method B test depending upon which test procedure is to be used with actual samples.

### 10.3 Test Method A:

10.3.1 The temperatures of the QCMs shall be set at the following values:

$$TQ1 \leq 90K \text{ and stable to within } \pm 0.5K$$

$$TQ2 = 160K \pm 0.5K$$

$$TQ3 = 298K \pm 0.5K$$

10.3.2 Wait for the system to attain equilibrium. Equilibrium is achieved when the frequencies of each QCM vary by less than 0.2 Hz per min averaged over a 20-min period, and  $TQ1$ ,  $TQ2$ , and  $TQ3$  are within  $\pm 0.5K$  of their set points.

10.3.3 Prepare and characterize a test sample in accordance with Section 9.

10.3.4 Vent the interlock chamber with clean dry  $GN_2$  in accordance with MIL-P-27401C, Type I, Grade B (99.99 % pure) or better.

10.3.5 Open the load port of the interlock chamber and remove the effusion cell. Continue to purge the interlock chamber with  $GN_2$ .

10.3.6 Place the test sample in the effusion cell or perform a blank sample test. A blank sample test shall be performed at least once in every six months of continuous operation. Blank sample tests shall also be performed if the test apparatus has not been operated continuously or following exposure of the test chamber to room atmosphere.

NOTE 17—A blank run consists of exercising the test method with a clean, empty effusion cell prepared as in 10.2.4-10.2.9. During the blank run preparation, the effusion cell shall be handled as if a sample were to be loaded. Round-robin tests will be used to determine the required frequency for blank sample tests.

10.3.7 Install the effusion cell in the interlock chamber and close the load port.

NOTE 18—Shut off the  $GN_2$  purge before sealing the load port.

10.3.8 Initiate data acquisition and verify that the QCMs and data acquisition system are operating properly.

10.3.9 Record data at 5- or 10-min time intervals. An automated data collection system is recommended. Data recording should start approximately 20 min before Time 0. This verifies the equilibrium stability of the system. The following data shall be recorded:

10.3.9.1 Frequencies and temperatures of the QCMs.

10.3.9.2 Temperature of the effusion cell, and

10.3.9.3 Time, with the beginning of the evaluation of the interlock chamber being “Time 0.”

10.3.10 Evacuate the interlock chamber for 5 min.

NOTE 19—During a blank sample test, the vacuum system shall be capable of evacuating the interlock chamber containing the empty effusion cell from one atmosphere to less than  $2 \times 10^{-3}$  Pa ( $1 \times 10^{-5}$  torr) in 5 min.

10.3.11 Open the valve between the interlock and main test chambers.

10.3.12 Move the effusion cell into the main chamber.

NOTE 20—The distance between the effusion cell orifice and the collector surfaces of the QCMs shall be set at 150 mm  $\pm$  1 mm.

10.3.13 Each material shall be tested at three temperatures. The accuracy of the temperatures shall be within  $\pm 1$ K ( $\pm 1^\circ\text{C}$ ). The temperatures shall be controlled to within  $\pm 0.5$ K ( $\pm 0.5^\circ\text{C}$ ). A new sample shall be used for each test.

10.3.14 For the first test, heat the effusion cell to 398K (125°C) (*TS1*).

10.3.15 For the second test, heat the effusion cell to 348K (75°C) (*TS2*).

10.3.16 For the third test, heat the effusion cell to 323K (50°C) (*TS3*) unless the deposition at 348K (75°C) on QCM1 is 5 % or less of that at 398K, in which case *TS3* shall be 373K (100°C).

10.3.17 Run the isothermal test for one to five days for each sample. The test can be terminated earlier than five days when the mass accumulation rate on QCM1 is within a factor of two of the background mass accumulation. The background accumulation rate is a function of the effusion cell temperature and test chamber geometry. For the standard test chamber geometry, this is a deposition rate of approximately  $5 \times 10^{-13}$  g·cm<sup>-2</sup>·s<sup>-1</sup> on QCM1 and a frequency change of 0.4 Hz/h (approximately 10 Hz/day) for a 10-MHz crystal. Although the effusion cell is not the only source of the background deposition, this is equivalent to the outgassing from the effusion cell of approximately  $5 \times 10^{-10}$  g·s<sup>-1</sup>.

NOTE 21—The higher the background deposition the lower the sensitivity of the apparatus for the measurement of outgassing. Therefore, the background flux should be small relative to the molecular flux from the test specimen.

10.3.18 If at any time QCM1 accumulates a deposit of more than  $2 \times 10^{-4}$  g/cm<sup>2</sup>, the test should be terminated. This represents a frequency change of approximately 45 KHz for a 10-MHz crystal. Thicker deposits of some contaminants may not couple firmly to the oscillating crystal, and inaccurate measurements will result. The outgassing test should then be repeated using a smaller sample mass to prevent QCM1 from accumulating more than  $2 \times 10^{-4}$  g/cm<sup>2</sup> before the end of the scheduled test period.

10.3.19 At the termination of the isothermal outgassing/deposition test, set the effusion cell temperature to 298K (25°C).

10.3.20 Move the effusion cell to the interlock chamber.

10.3.21 Close the valve between the interlock chamber and main test chamber.

10.3.22 Backfill the interlock chamber with clean, dry GN<sub>2</sub> per MIL-P-27401C, Type I, Grade B (99.99 % pure) or better.

10.3.23 When the effusion cell has cooled to within 10°C of the room ambient temperature, open the interlock chamber load port and remove the effusion cell. Purge the interlock chamber with GN<sub>2</sub> while the effusion cell is removed.

10.3.24 Remove the test sample from the effusion cell and weigh the sample immediately.

10.3.25 To prepare for starting another material test, proceed to 10.2.4-10.2.9.

10.3.26 Proceed to 10.5 and perform a QCM thermogravimetric analysis test. This can be started in parallel with 10.3.22-10.3.25.

10.4 *Test Method B:*

10.4.1 The temperatures of the QCMs shall be set at the following values:

*TQ1*  $\leq$  90K stable to within  $\pm 0.5$ K

*TQ2* and *TQ3* temperatures shall be user specified. A fourth QCM may be used

10.4.2 Run the isothermal outgassing/deposition tests as specified in 10.3.2-10.3.26. The effusion cell temperatures of 10.3.14-10.3.16 may be replaced by user-specified values.

10.5 *QCM Thermogravimetric Analysis (QTGA) Test Method:*

NOTE 22—Users should be aware that the QTGA heating rate can affect the test data. See Note 7.

10.5.1 The following test data shall be recorded in intervals of 1 min or less through the duration of the QTGA test:

10.5.1.1 Frequencies and temperatures of the QCMs and

10.5.1.2 Time since the beginning of the test.

10.5.2 Heat QCM1 at a controlled rate to measure evaporation rates from its collector surface. The QCM shall be heated at a maximum and constant rate of 1K/min from its base isothermal operating temperature (*TQ1*) to 398K.

10.5.3 The QCM temperature shall be maintained at 398K (125°C) until the QCM frequency becomes stable and then allowed to cool to temperature *TQ1*.

10.5.4 Heat each of the other collector QCMs (QCM2 and QCM3) consecutively at a rate not to exceed 1K/min until their temperatures reach 398K (125°C).

10.5.5 The temperatures of the QCM2 and QCM3 shall be maintained at 398K until the QCM frequency becomes stable and then allowed to cool to their respective temperatures of *TQ2* and *TQ3*.

10.5.6 When the QCMs have regained their equilibrium temperatures, compare their frequencies with the values recorded at the beginning of the isothermal outgassing/deposition test.

10.5.7 If the frequency of any QCM is greater than the initial value by more than 200 Hz, proceed to 10.6.

10.5.8 Proceed to 10.2.13 to perform another material test.

10.6 *Apparatus Warm-Up:*



10.6.1 This procedure shall be followed only if it is necessary to gain access to the interior of the vacuum chamber for some reason, such as to clean a QCM or to repair the apparatus.

10.6.2 Shut off all cryogenic heat sinks and electrical power supplies and allow the apparatus to warm up to ambient room temperature while under vacuum.

10.6.3 Isolate the main chamber and the interlock chamber from the vacuum system.

10.6.4 Vent the main test chamber and the interlock chamber with GN<sub>2</sub> in accordance with MIL-P-27401C, Type I, Grade B (99.99 % pure) or better, to one atmosphere pressure.

10.6.5 After accessing the interior of the test chamber, proceed to the test chamber preparation in 10.2.

**11. Data Processing**

11.1 The purpose of data processing is to convert the measured QCM frequencies into units of mass.<sup>13</sup> For the isothermal deposition test, the mass flow from the effusion cell is computed in terms of in-situ TML and in-situ VCM. For the thermal desorption test, the mass density remaining on the QCM is computed. Data processing is similar for Test Methods A and B. Equations for ex-situ TML are presented for completeness.

11.2 *Ex-Situ Measurements*—The ex-situ TML, TML<sub>ex</sub>, is computed as shown in the following equation:

$$TML_{ex} = 100 \times \left[ \frac{m_{s+h}(i) - m_{s+h}(f)}{m_{s+h}(i) - m_h} \right] \quad (1)$$

where *m* indicates a measured mass, the subscripts *s* and *h* indicate the sample and the holder/substrate (if any), and *i* and *f* indicate measurements before and after the vacuum test, respectively. The units of TML are percent. (See 3.1.13.)

**11.3 QCM Measurements:**

11.3.1 *Total Mass Deposited*—The mass density deposited on a QCM at temperature *T<sub>q</sub>* from a sample at temperature *T<sub>s</sub>* at time *t* is *m<sub>d</sub>*, which is given by the following equation:

$$m_d(T_q, T_s, t) = K_s [f(T_q, T_s, t) - f(T_q, T_s, 0)] \quad (2)$$

where:

- m<sub>d</sub>*(*T<sub>q</sub>*, *T<sub>s</sub>*, *t*) = deposited mass (g/cm<sup>2</sup>),
- f*(*T<sub>q</sub>*, *T<sub>s</sub>*, *t*) = frequency of the QCM at Time *t* (Hz),
- f*(*T<sub>q</sub>*, *T<sub>s</sub>*, 0) = frequency of the QCM at Time 0 (Hz), and
- K<sub>s</sub>* = the QCM mass sensitivity factor (g·cm<sup>-2</sup>·Hz<sup>-1</sup>).

(See Table 1 for recommended values of *K<sub>s</sub>*.) Time zero is defined as the time at which the evacuation of the sample interlock chamber begins.<sup>14</sup>

<sup>13</sup> This section is based on the discussion of QCM data reduction for this type of measurement, by Glassford, A. P. M. and Garrett, J. W. in *Characterization of Contamination Generation Characteristics of Satellite Materials*, WRDC-TR-89-4114, 22 Nov., 1989.

<sup>14</sup> If the point-to-point noise in any QCM frequency measurement is substantial compared to the total change in QCM beat frequency over the course of the isothermal outgassing test, the baseline frequency, *F*(*T<sub>q</sub>*, *T<sub>s</sub>*, 0), may be calculated as the QCM's average frequency over the period of evacuation of the sample interlock chamber, so long as the drift specification from 10.3.2 is not exceeded during that period.

11.3.2 *QCM-to-Effusion Cell Orifice View Factor*—The mass density deposited on a QCM is related to the mass that has left the effusion cell by means of the QCM-to-effusion cell orifice view factor, *F<sub>q</sub>*. The following equation defines *F<sub>q</sub>*:

$$F_q = \frac{\pi r^2 W_{LR}}{B(\phi_1)\cos(\phi_1)\cos(\phi_2)} \quad (3)$$

where:

- F<sub>q</sub>* = view factor for QCMq (cm<sup>2</sup>),
- r* = distance from the orifice to the QCMq crystal (cm),
- $\phi_1$  = the angle between the QCMq-to-cell orifice line of sight and the orifice normal,
- $\phi_2$  = the angle between the line of sight and the QCMq normal,
- L* = the length of the effusion cell orifice (mm),
- R* = the radius of the effusion cell orifice (mm),
- W<sub>LR</sub>* = the “Clausing transmission probability” for the effusion cell orifice, and
- B*( $\phi_1$ ) = the “Clausing angular flow distribution” for the effusion cell orifice and the QCMq position (see Figs. 3-5).

NOTE 23—In Test Method A, the nominal values of dimensions shown in Eq 3 are as follows, for all three QCMs:

$$\begin{aligned} L &= 2R = 3 \text{ mm} \\ r &= 150 \text{ mm} \\ \phi_1 &= 10^\circ \\ \phi_2 &= 0^\circ \end{aligned} \quad (4)$$

The view factor, *F<sub>q</sub>*, will be the same for each QCM for Test Method A. In computing the view factors, actual, measured values shall be used.

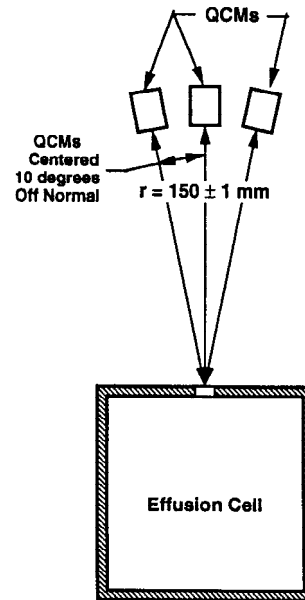

FIG. 3 QCMs—Effusion Cell Critical Dimensions

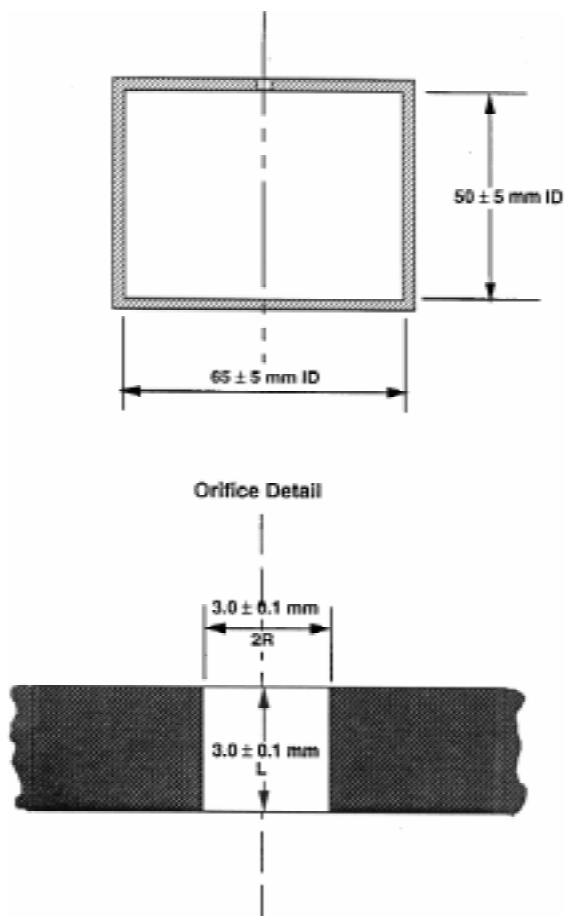

FIG. 4 Effusion Cell

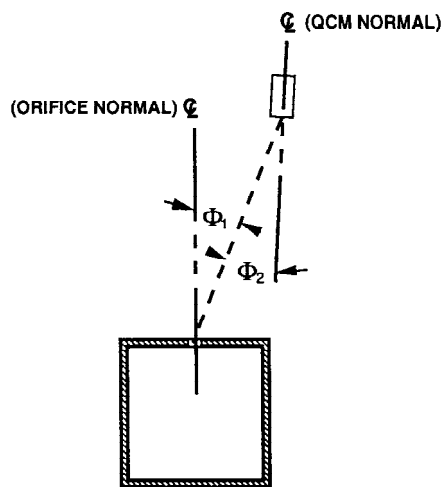

FIG. 5 QCM—Effusion Cell View Factor Angles

11.3.3 *Angular Flow Distribution*—The flow distribution from an orifice of finite length,  $B(\phi_1)$ , has been computed by Clausing.<sup>15</sup> The angular distribution is defined by Eq 5-8.<sup>16</sup>

$$B(\phi_1) = 1 - \frac{2}{\pi} (1 - \gamma) [\sin^{-1}(\rho) + \rho \sqrt{1 - \rho^2}] \quad (5)$$

$$+ \frac{4}{3\pi} (1 - 2\gamma) \frac{1 - (1 - \rho^2)^{3/2}}{\rho} \text{ for } \rho < 1$$

and:

$$B(\phi_1) = \gamma + \frac{4}{3\pi} \frac{1 - 2\gamma}{\rho} \text{ for } \rho > 1 \quad (6)$$

where:

$$\rho = \frac{L \tan(\phi_1)}{2R} \quad (7)$$

and:

$$\gamma = \frac{\sqrt{L^2 + 4R^2} - L}{2R + \sqrt{L^2 + 4R^2}} \quad (8)$$

NOTE 24—The value returned by the function  $\sin^{-1}(\rho)$  in Eq 5 must be in units of radians for the equation to be valid.

For the nominal test geometry, the value of  $B(\phi_1)$  is 0.8881. When using Test Method B, the flow angular distribution may be different if a nonstandard cell orifice or QCM geometry is used.

11.3.4 *Orifice Transmission Probability*—The orifice transmission probability  $W_{L/R}$ , or Clausing coefficient, is the fraction of molecules entering the upstream face of the orifice that pass through the downstream face. For isotropic molecular flow upstream, the  $W_{L/R}$  depends only on the shape of the orifice.<sup>16,17</sup> For the nominal orifice,  $L = 2R = 3$  mm, the value of  $W_{L/R}$  is 0.5136.<sup>18</sup> When using Test Method B, the transmission probability may be different if a nonstandard cell orifice is used. Table 2 presents value of  $W_{L/R}$  to be used for cylindrical

<sup>16</sup> Lyubotov, Y. N., "Calculation of the Directivity Diagrams for Molecular Flow from a Cylinder," in *Molecular Flow in Vessels*, a special report translated from Russian by Furry, W. H., and Woods, J. S., Consultants Bureau, New York, 1967, pp. 53-60.

<sup>17</sup> Clausing, P., *Ann. Physik*, Vol 12, 1932.

<sup>18</sup> Dushman, S., *Scientific Foundations of Vacuum Technique*, 2nd edition, John Wiley and Sons, Inc., New York, 1962.

TABLE 2 Values of the Orifice Transmission Probability,  $W_{L/R}$

$L/R$	$W_{L/R}$	$L/R$	$W_{L/R}$
0	1	1.9	0.5256
0.1	0.9524	2.0	0.5136
0.2	0.9092	2.2	0.4914
0.3	0.8699	2.4	0.4711
0.4	0.8341	2.6	0.4527
0.5	0.8013	2.8	0.4359
0.6	0.7711	3.0	0.4205
0.7	0.7434	3.2	0.4062
0.8	0.7177	3.4	0.3931
0.9	0.6940	3.6	0.3809
1.0	0.6720	3.8	0.3695
1.1	0.6514	4.0	0.3589
1.2	0.6320	5	0.3146
1.3	0.6139	6	0.2807
1.4	0.5970	7	0.2537
1.5	0.5810	8	0.2316
1.6	0.5659	9	0.2131
1.7	0.5518	10	0.1973
1.8	0.5384	...	...

<sup>15</sup> Clausing, P., *Z. Phys.*, Vol 66, 1930.

orifices.<sup>18</sup> Linear interpolation between values shown in Table 2 is acceptable.

11.3.5 Combining Eq 2-7, one computes a value of 415.08 cm<sup>2</sup> for the value of  $F_q$  for all QCMs in the case of Test Method A nominal dimensions.

11.3.6 *In-Situ TML (Total Mass Loss)*—The time-dependent in-situ total mass loss is computed by multiplying the mass density deposited on the cryogenically cooled QCM (QCM1) by that QCM's view factor to the effusion cell orifice.

11.3.6.1 Eq 9 presents the in-situ TML in the units of percent of initial sample mass.

$$TML(T_q, T_s, t) = 100 \times \left[ \frac{F_1 m_d(T, T, t)}{m_{s+h}(i) - m_h} \right] \quad (9)$$

where:

$F_1$  = view factor of QCM1 to the effusion cell orifice as defined in Eq 3.

11.3.6.2 Eq 10 presents the in-situ TML in units of  $\mu\text{g}/\text{cm}^2$ .

$$TML(T_1, T_s, t) = 10^6 \times \left[ \frac{F_1 m_d(T_1, T_s, t)}{A_s} \right] \quad (10)$$

where:

$A_s$  = sample surface area (cm<sup>2</sup>).

11.3.7 *VCM (Volatile Condensable Material)*—The time-dependent VCMs at QT2, QT3, and QT4 (if present) are computed by multiplying the mass density deposited on QCMs 2, 3, and (4) by those QCMs' respective view factors to the effusion cell orifice.

11.3.7.1 Eq 11 presents the VCM in units of percent.

$$VCM(T_q, T_s, t) = 100 \times \left[ \frac{F_q m_d(T_q, T_s, t)}{m_{s+h}(i) - m_h} \right] \quad (11)$$

where:

$q$  = 2, 3, and 4 (if present).

11.3.7.2 Eq 12 presents the VCM in units of  $\mu\text{g}/\text{cm}^2$ .

$$VCM(T_q, T_s, t) = 10^6 \times \left[ \frac{F_q m_d(T_q, T_s, t)}{A_s} \right] \quad (12)$$

NOTE 25—The measured deposition rate is the difference between the arrival rate (which depends on apparatus geometry) and the reevaporation rate (which depends only on the QCM temperature). For this reason, the comparability of measurements of VCM for nonstandard apparatus geometries ( $r$ ,  $\phi_1$ ,  $\phi_2$ ,  $L$ , and  $R$ ) may be difficult. Careful reporting of all non-standard apparatus geometries is crucial to the data's utility.

11.3.8 *OGR (Outgassing Rate)*:

11.3.8.1 The time-dependent outgassing rates for species condensable on a QCM are computed by first differentiating the mass density deposited on a QCM as a function of time to give the deposition rate on the QCM. This can be obtained from a point-by-point differentiation of the QCM data as given in Eq 13.

$$\dot{m}_d(T_q, T_s, t) = \left[ \frac{m_d(T_q, T_s, t+1) - m_d(T_q, T_s, t)}{(t+1) - (t)} \right] \quad (13)$$

where:

$(t+1)$  and  $(t)$  = the times that data were collected at consecutive intervals (s) and

$\dot{m}_d(T_q, T_s, t)$  = the deposition rate on QCMs 1, 2, 3, and 4 ( $\text{g}\cdot\text{cm}^{-2}\cdot\text{s}^{-1}$ ).

11.3.8.2 The deposition rate on a QCM  $\dot{m}_d(T_q, T_s, t)$ , is then used with the QCM-to-cell orifice view factor,  $F_q$ , and the sample surface area,  $A_s$ , in the following equation to calculate the total outgassing rate from the sample,  $OGR(T_q, T_s, t)$ , in units of  $\text{g}\cdot\text{cm}^{-2}\cdot\text{s}^{-1}$ .

$$OGR(T_q, T_s, t) = \frac{F_q m_d(T_q, T_s, t)}{A_s} \quad (14)$$

11.3.8.3 The outgassing rate can be normalized with respect to the initial sample mass rather than the surface area and can be expressed in units of  $\text{g}\cdot\text{g}^{-1}\cdot\text{s}^{-1}$  as shown in Eq 15.

$$OGR(T_q, T_s, t) = \frac{F_q m_d(T_q, T_s, t)}{m_{s+h}(i) - m_h} \quad (15)$$

NOTE 26—The total outgassing rates from a sample are calculated from the data from the <90K QCM. As with the TML calculations, this analysis assumes that essentially all of the outgassing flux impinging on the < 90K QCM is condensed.

11.3.9 *QCM Thermogravimetric Analysis (QTGA)*:

11.3.9.1 QTGA data shall be reported as mass density ( $\text{g}/\text{cm}^2$ ) versus temperature and time using the zero frequency at time zero as defined in 11.3.1. Eq 16 defines the QTGA measurement.

$$m_Q(T_q, t) = K_s[f(T_q, t) - f(T_q, 0)] \quad (16)$$

where:

$m_Q$  = QTGA mass loss ( $\text{g}/\text{cm}^2$ ).

11.3.9.2 Corrections for the frequency-temperature responses of the individual QCMs are optional. The shape of frequency-temperature response functions of QCMs varies greatly. Therefore, methods for correcting data for this have not been specified. The frequency-temperature responses can be obtained from the blank run test data.

11.3.9.3 If the most recent blank run results are not available as a separate, referenced report, the blank run results shall be appended to the data report, in the same format as the test data.

## 12. Report

12.1 The standard format specified in this section is intended to facilitate the dissemination of data generated under this standard by providing a uniform way of reporting results by electronic media and on-line databases, such as the NASA MAPTIS (Materials and Processes Technical Information Service).

12.2 *Data Report Form*:

12.2.1 The recommended Data Report Form is shown in Fig. 6.

12.2.2 Each blank space on the report form shall be a single field in the file and listed in the order shown on the form. The field number is shown in bold before the field.

12.2.3 Field one is marked either **A** or **B** depending upon whether Test Method A or B is used.

12.2.4 Each field shall be separated by a single tab, and tabs shall not be used within any field.

12.2.5 Fields do not need to have a fixed length.

12.2.6 Any fields not used shall be separated by a tab.

METHOD (A or B) (1) \_\_\_\_\_

DATE test started(2)	ORGANIZATION (3)
POINT OF CONTACT (4)	LOCATION
PHONE (5)	

TEST APPARATUS DESCRIPTION

Last Blank Run, Date (6)	Effusion Cell Material (7)
Effusion Cell Orifice Dimensions (8) L =      mm	(9) R =      mm

SPECIMEN IDENTIFICATION

Product Name (10)	Manufacturer (11)	Dimensions (12)      mm
Lot/Batch Number (13)	Supplier (14)	
Fiber/Filler composition (15)	volume (16)	%
Holder/substrate ID (17)	Mass of holder, m <sub>h</sub> (18)      g	

Processing History (19) \_\_\_\_\_

Preconditioning (20) \_\_\_\_\_

Sample Comments (21) \_\_\_\_\_

Test Chamber Pres., Time 0 (22)      torr	Interlock Chamber Pres., 5 min. (23)      torr	
Test Chamber Pres., 30 min. (24)      torr	Sample Temp. (T <sub>s</sub> ) (25)      K	Test Duration (26)      hrs

TEST RESULTS

Sample mass + holder/substrate mass, before test, m <sub>s+h</sub> (i) (27)	g
Sample mass + holder/substrate mass, after test, m <sub>s+h</sub> (f) (28)	g
Total Mass Loss of Specimen, TML <sub>ox</sub> = 100 × $\frac{m_{s+h}(i) - m_{s+h}(f)}{m_{s+h}(i) - m_h(i)}$ (29)	%

QCM	1	2	3	4 (If Used, Meth. B)
Initial Frequency (f) (Hz)	(30)	(35)	(40)	(45)
Final Frequency (f) (Hz)	(31)	(36)	(41)	(46)
Natural Frequency of QCM (MHz)	(32)	(37)	(42)	(47)
Sensitivity (K <sub>s</sub> )(g·cm <sup>-2</sup> ·Hz <sup>-1</sup> )	(33)	(38)	(43)	(48)
View Factors (F <sub>q</sub> ) (cm <sup>2</sup> )	(34)	(39)	(44)	(49)

GENERAL COMMENTS (50) \_\_\_\_\_

Method B, Deviations: (51) \_\_\_\_\_

Number of Lines of Data: (52) \_\_\_\_\_

FIG. 6 Outgassing/Deposition Test Data Form

12.2.7 For Test Method B, information on all allowed differences shall be listed in Field 51, including parameters that do not deviate from Test Method A. These differences include sample temperature, effusion cell orifice geometry, QCM temperatures, QCM to effusion cell distance and angles used for determining view factors, QCM surfaces, and inclusion of a fourth QCM.

12.3 *File Format*—All data shall be formatted as straight ASCII text with no special characters to ensure that files can be read by the widest possible range of systems.

12.4 *Data Fields:*

12.4.1 Calculated data shall be reported for inclusion in on-line databases (see Section 11). It is recommended that raw data be included in a second table.

12.4.2 *Deposition Test Data:*

12.4.2.1 Deposition test data shall be reported in the following order:

(1) Time from the start of the test (see 11.3.1 for the definition of t<sub>0</sub>). Negative times will be required because data recording is started before time zero (see 10.3.9).

(2) QCM1 temperature.

(3) TML (QCM1), %.

(4) QCM2 temperature.

(5) VCM2 (QCM2), %.

(6) QCM3 temperature.

(7) VCM3 (QCM3), %.

(8) QCM4 temperature (Test Method B, if appropriate).

(9) VCM4 (QCM4), % (Test Method B, if appropriate).

(10) Effusion cell temperature.

12.4.2.2 Temperatures shall be reported in kelvin.

12.4.2.3 A carriage return shall separate each line of data (mass % and temperatures) for a given time).

12.4.2.4 Each data point for a given time shall be separated by a single tab.

12.4.2.5 The first line of the data shall be headers for the columns (TML, VCM2, and so forth).

12.4.2.6 Time shall be recorded to a precision of 0.1 min.

12.4.2.7 Temperatures shall be recorded to a precision of 0.1K.

12.4.2.8 TML and VCM shall be recorded as floating point numbers with six digits of precision plus the exponent.

12.4.2.9 Table 3 shows an example of the data format for the deposition test.

12.4.3 *QTGA Test:*

**TABLE 3 Example of Deposition Test Data Format**

Time, min	TQ1, K	TML, %	TQ2, K	VCM2, %	TQ3, K	VCM3, %	Sample Temperature, K
-20.0	89.5	-0.242 095E-04	160.1	-0.224 859E-04	297.5	0.134 367E-04	306.8
-15.0	89.9	0.564 106E-05	160.5	-0.224 075E-04	297.6	0.138 284E-04	306.9
-10.0	90.0	0.705 132E-06	160.2	-0.846 159E-05	297.7	-0.223 292E-05	306.9
-5.0	89.9	0.140 243E-04	159.8	-0.738 430E-05	297.5	-0.121 831E-04	306.6
0.0	89.8	0.000 000E+00	160.0	0.000 000E+00	297.5	0.000 000E+00	306.9
5.0	90.0	0.137 123E-01	160.4	0.617 812E-02	297.5	0.269 596E-03	332.7
10.0	90.0	0.297 900E-01	160.3	0.232 908E-01	297.8	0.133 231E-03	335.2
15.0	89.8	0.466 861E-01	160.3	0.286 661E-01	297.6	0.389 938E-03	347.0
20.0	89.8	0.640 877E-01	160.1	0.318 432E-01	297.5	0.550 395E-03	348.5
25.0	89.9	0.816 417E-01	160.4	0.474 235E-01	297.5	0.438 083E-03	348.1
30.0	89.9	0.990 031E-01	160.4	0.587 759E-01	297.8	0.438 083E-03	348.2
35.0	89.9	0.115 626E+00	160.2	0.593 455E-01	297.6	0.702 821E-03	348.1
40.0	90.1	0.131 463E+00	159.9	0.699 276E-01	297.5	0.590 509E-03	348.2
45.0	89.6	0.146 651E+00	160.5	0.830 048E-01	297.6	0.622 593E-03	348.2
50.0	89.8	0.161 156E+00	160.3	0.842 243E-01	297.9	0.694 830E-03	348.1
55.0	90.0	0.174 995E+00	160.2	0.899 366E-01	297.6	0.783 049E-03	348.2
60.0	89.5	0.188 201E+00	159.7	0.998 127E-01	297.5	0.863 278E-03	348.2
65.0	89.9	0.201 030E+00	160.3	0.110 315E+00	297.5	0.823 164E-03	348.2
70.0	89.9	0.213 377E+00	160.4	0.108 076E+00	297.9	0.895 401E-03	348.1
75.0	89.8	0.225 411E+00	160.2	0.113 163E+00	297.6	0.967 598E-03	348.2
80.0	89.8	0.237 076E+00	160.2	0.125 574E+00	297.7	0.991 651E-03	348.1
85.0	89.7	0.248 549E+00	160.0	0.133 356E+00	297.5	0.967 598E-03	348.2
90.0	89.7	0.259 701E+00	159.7	0.133 613E+00	297.9	0.887 370E-03	348.1
95.0	89.7	0.270 580E+00	159.7	0.136 870E+00	298.0	0.107 991E-02	348.1
100.0	89.8	0.281 290E+00	160.0	0.150 766E+00	298.1	0.103 980E-02	348.2
105.0	89.8	0.291 896E+00	159.6	0.149 771E+00	298.1	0.927 484E-03	348.2
110.0	89.8	0.302 109E+00	159.8	0.151 600E+00	298.1	0.101 574E-02	348.2
115.0	89.8	0.312 266E+00	160.3	0.164 886E+00	298.2	0.879 339E-03	348.2
120.0	89.8	0.322 335E+00	159.9	0.166 531E+00	298.1	0.105 586E-02	348.1
125.0	89.9	0.332 123E+00	159.4	0.168 416E+00	298.1	0.109 597E-02	348.2
130.0	89.9	0.341 638E+00	160.1	0.171 449E+00	298.2	0.103 980E-02	348.2
135.0	89.9	0.351 065E+00	159.7	0.183 146E+00	298.2	0.100 771E-02	348.2
140.0	89.9	0.360 467E+00	159.6	0.191 072E+00	298.1	0.119 222E-02	348.2
145.0	89.9	0.369 637E+00	160.1	0.189 203E+00	297.5	0.115 211E-02	348.5
150.0	89.9	0.378 687E+00	159.9	0.191 024E+00	297.5	0.999 682E-03	348.1
155.0	89.9	0.387 569E+00	159.8	0.204 270E+00	297.8	0.111 199E-02	348.3
160.0	89.8	0.396 354E+00	159.2	0.206 444E+00	297.9	0.108 794E-02	348.2
165.0	89.8	0.404 946E+00	160.1	0.206 356E+00	298.1	0.999 682E-03	348.2
170.0	89.8	0.413 426E+00	159.9	0.216 088E+00	298.1	0.114 408E-02	348.2
175.0	89.9	0.421 866E+00	159.7	0.221 736E+00	298.2	0.116 01E-02	348.2
180.0	89.9	0.430 058E+00	159.6	0.219 722E+00	298.2	0.105 586E-02	348.3
185.0	89.9	0.438 209E+00	159.8	0.222 819E+00	298.2	0.855 286E-03	348.2
190.0	89.9	0.446 360E+00	159.9	0.225 916E+00	298.2	0.117 028E-02	348.2

12.4.3.1 QTGA data shall be reported in the following order:

- (1) Time from the start of the test, min.
- (2) QCM1 temperature, K.
- (3) QCM1, g/cm<sup>2</sup>.
- (4) QCM2 temperature, K.
- (5) QCM2, g/cm<sup>2</sup>.
- (6) QCM3 temperature, K.
- (7) QCM3, g/cm<sup>2</sup>.
- (8) QCM4 temperature, K (Test Method B, if appropriate).
- (9) QCM4, g/cm<sup>2</sup> (Test Method B, if appropriate).

12.4.3.2 Temperatures shall be reported in kelvin.

12.4.3.3 A carriage return shall separate each line of data (frequencies and temperatures) for a given time).

12.4.3.4 Each data point for a given time shall be separated by a single tab.

12.4.3.5 The first line of the data shall be headers for the columns (QCM1 and so forth).

12.4.3.6 The second line of the data shall give the units used for the measurements.

12.4.3.7 Time shall be recorded to a precision of 0.1 min.

12.4.3.8 Temperatures shall be recorded to a precision of 0.1K.

12.4.3.9 TML shall be recorded as floating point numbers with six digits of precision plus the exponent.

12.4.3.10 Table 4 shows an example of the data format for the QTGA test.

### 13. Precision and Bias

13.1 Precision and bias have not been determined for this test method. Round-robin, interlaboratory tests will be performed.

### 14. Keywords

14.1 contamination control; materials; molecular deposition; outgassing; spacecraft

**TABLE 4 Example of QTGA Test Data Format**

Time, min	TQ1, K	QCM1, g/cm <sup>2</sup>	TQ2, K	QCM2, g/cm <sup>2</sup>	TQ3, K	QCM3, g/cm <sup>2</sup>
0.0	89.7	0.728 955E-04	159.5	0.442 583E-04	298.1	0.173 974E-04
1.0	89.8	0.727 032E-04	160.0	0.437 595E-04	298.1	0.173 815E-04
2.0	89.8	0.726 926E-04	159.5	0.442 880E-04	298.2	0.173 855E-04
3.0	89.9	0.726 890E-04	159.9	0.438 937E-04	298.2	0.174 023E-04
4.0	90.2	0.726 872E-04	159.7	0.440 895E-04	298.2	0.173 886E-04
5.0	91.6	0.721 729E-04	159.6	0.441 608E-04	298.2	0.173 855E-04
6.0	92.7	0.723 027E-04	159.9	0.439 189E-04	298.2	0.173 708E-04
7.0	93.5	0.726 886E-04	159.5	0.443 438E-04	298.2	0.173 735E-04
8.0	95.1	0.724 658E-04	159.9	0.437 940E-04	298.2	0.173 859E-04
9.0	96.6	0.722 367E-04	159.5	0.443 704E-04	298.2	0.173 903E-04
10.0	97.5	0.719 404E-04	159.8	0.438 051E-04	298.2	0.173 810E-04
11.0	97.8	0.726 593E-04	159.6	0.443 137E-04	298.2	0.173 677E-04
12.0	99.0	0.726 137E-04	159.7	0.439 243E-04	298.2	0.173 766E-04
13.0	100.7	0.720 028E-04	159.5	0.441 418E-04	298.2	0.173 921E-04
14.0	101.6	0.718 704E-04	159.5	0.440 642E-04	298.3	0.173 832E-04
15.0	101.4	0.727 967E-04	159.7	0.439 819E-04	298.3	0.173 708E-04
16.0	103.0	0.724 750E-04	159.5	0.442 246E-04	298.3	0.173 589E-04
17.0	104.5	0.719 705E-04	159.8	0.438 937E-04	298.3	0.173 717E-04
18.0	105.4	0.717 946E-04	159.6	0.442 915E-04	298.3	0.173 801E-04
19.0	105.4	0.726 115E-04	159.8	0.438 113E-04	298.3	0.173 762E-04
20.0	106.7	0.725 198E-04	159.6	0.443 061E-04	298.3	0.173 593E-04
21.0	108.6	0.716 754E-04	159.9	0.438 334E-04	298.2	0.173 469E-04
22.0	108.7	0.723 794E-04	159.7	0.443 699E-04	298.2	0.173 669E-04
23.0	110.0	0.721 065E-04	159.8	0.438 321E-04	298.2	0.173 824E-04
24.0	111.2	0.721 649E-04	159.7	0.442 375E-04	298.3	0.173 762E-04
25.0	112.1	0.722 327E-04	159.8	0.439 282E-04	298.3	0.173 593E-04
26.0	113.4	0.720 892E-04	159.5	0.441 878E-04	298.4	0.173 447E-04
27.0	114.1	0.722 992E-04	159.6	0.441 156E-04	298.4	0.173 593E-04
28.0	115.2	0.721 446E-04	159.8	0.439 495E-04	298.3	0.173 739E-04
29.0	116.1	0.722 208E-04	159.5	0.442 680E-04	298.3	0.173 669E-04
30.0	117.1	0.721 858E-04	159.9	0.438 401E-04	298.3	0.173 456E-04
31.0	118.2	0.721 171E-04	159.7	0.443 779E-04	298.3	0.173 518E-04
32.0	119.3	0.721 344E-04	159.9	0.438 281E-04	298.3	0.173 496E-04
33.0	120.3	0.721 490E-04	159.5	0.443 371E-04	298.2	0.173 762E-04
34.0	121.2	0.721 685E-04	159.9	0.437 883E-04	298.3	0.173 562E-04
35.0	122.4	0.720 360E-04	159.8	0.443 163E-04	298.3	0.173 447E-04
36.0	123.3	0.721 375E-04	159.8	0.439 052E-04	298.3	0.173 482E-04
37.0	124.2	0.720 174E-04	159.7	0.442 791E-04	298.3	0.173 584E-04
38.0	125.3	0.720 989E-04	159.8	0.439 207E-04	298.3	0.173 655E-04
39.0	126.2	0.721 295E-04	159.6	0.440 651E-04	298.3	0.173 638E-04
40.0	127.2	0.720 290E-04	159.6	0.441 790E-04	298.3	0.173 549E-04
41.0	128.2	0.720 210E-04	159.7	0.439 043E-04	298.3	0.173 341E-04
42.0	129.3	0.720 378E-04	159.8	0.443 376E-04	298.3	0.173 713E-04
43.0	130.2	0.721 074E-04	159.9	0.437 790E-04	298.3	0.173 558E-04

*ASTM International takes no position respecting the validity of any patent rights asserted in connection with any item mentioned in this standard. Users of this standard are expressly advised that determination of the validity of any such patent rights, and the risk of infringement of such rights, are entirely their own responsibility.*

*This standard is subject to revision at any time by the responsible technical committee and must be reviewed every five years and if not revised, either reapproved or withdrawn. Your comments are invited either for revision of this standard or for additional standards and should be addressed to ASTM International Headquarters. Your comments will receive careful consideration at a meeting of the responsible technical committee, which you may attend. If you feel that your comments have not received a fair hearing you should make your views known to the ASTM Committee on Standards, at the address shown below.*

*This standard is copyrighted by ASTM International, 100 Barr Harbor Drive, PO Box C700, West Conshohocken, PA 19428-2959, United States. Individual reprints (single or multiple copies) of this standard may be obtained by contacting ASTM at the above address or at 610-832-9585 (phone), 610-832-9555 (fax), or [service@astm.org](mailto:service@astm.org) (e-mail); or through the ASTM website ([www.astm.org](http://www.astm.org)).*