



Standard Guide for Marine Vessel Structural Inspection Considerations¹

This standard is issued under the fixed designation F 1754; the number immediately following the designation indicates the year of original adoption or, in the case of revision, the year of last revision. A number in parentheses indicates the year of last approval. A superscript epsilon (ϵ) indicates an editorial change since the last revision or reapproval.

1. Scope

1.1 This guide covers information to develop and implement a marine vessel inspection process. It is intended to provide considerations for persons interested in planning, organizing, and implementing a structural survey plan for a marine vessel, especially during the design phase of the vessel. It is intended to be used in conjunction with any other required inspection or survey requirements but can form the basis for such planning in the absence of other such applicable requirements.

1.2 This guide provides owners, operators, shipyards, and designers with a plan for developing a detailed inspection process that covers all stages of the operating life of a marine vessel, including the design, construction, and in-service periods. This plan may be developed and used in concert with classification society and flag state surveys and inspections.

1.3 This guide also provides the basis for development of a recommended corrective action plan for typical structural deficiencies or deviations, or both.

1.4 *This standard does not purport to address all of the safety concerns, if any, associated with its use. It is the responsibility of the user of this standard to establish appropriate safety and health practices and determine the applicability of regulatory limitations prior to use.*

1.5 All portions of this guide may not be applicable to all vessels or shipyards since many yard-specific standards to ensure contracted level of quality are in existence.

2. Referenced Documents

2.1 *ASTM Standards:*²

F 1053/F 1053M Guide for Steel Hull Construction Tolerances [Metric]³

3. Terminology

3.1 *Definitions of Terms Specific to This Standard:*

¹ This guide is under the jurisdiction of ASTM Committee F25 on Ships and Marine Technology and is the direct responsibility of Subcommittee F25.01 on Structures.

Current edition approved May 1, 2004. Published May 2004. Originally approved in 1996. Last previous edition approved in 1997 as F 1754 - 97.

² For referenced ASTM standards, visit the ASTM website, www.astm.org, or contact ASTM Customer Service at service@astm.org. For *Annual Book of ASTM Standards* volume information, refer to the standard's Document Summary page on the ASTM website.

³ Withdrawn.

3.1.1 *blind spots, n*—areas of a vessel's structure that cannot be visibly or electronically inspected for failure.

3.1.2 *large tanks, n*—tanks of such dimension as to have uninspectable heights greater than 10 m.

3.1.3 *telltale areas, n*—areas of a ship's structure identified by analyses and investigations during design development as being subject to higher stresses or more susceptible to fatigue than others, even though the higher stresses are still within allowable limits. Also, areas identified after the vessel is placed in service that continue to experience active or recurring cracking in the watertight envelope or that affect the structural integrity of the vessel.

4. Introduction

4.1 As stated earlier, the intent of this guide is to assist in the preparation of an inspection plan for a marine vessel during its design, construction, and in-service stages and to plan for inspection during the design. This guide should be used in the preparation of a specific inspection program for the construction of a specific marine vessel. It is not intended to set any stringent requirements for the structural inspections of any particular vessel. The suggestions for various inspection considerations in this guide are presented for the purpose of making available for review and use a broad set of guidelines.

4.2 This guide is applicable to all commercial and pleasure marine vessels. Although the references generally apply to steel and aluminum welded hulls, the overall aspects may be applied to any material or type of construction.

4.3 At any point of its construction or service life, the vessel may require classification society or flag state regulatory inspections, or both, as well as shipowner's surveys. The surveys, depending on occasion, should consider the general condition of the vessel, provide a detailed condition assessment, obtain data to determine corrosion rate and damage, or obtain information for repair specification development, or a combination thereof. The inspection plan should take into account all of these types of information in its development. On occasions, the surveys also should obtain data on rate of coating breakdown.

4.4 Because of severe loadings, excessive wastage, poor structural design, improper use of materials, excessive fatigue cycling, and so forth, failure may occur at any structure component at some stress value that is much less than the theoretically allowable limit. Therefore, detection of such

conditions by careful analysis and by sufficient inspection throughout the entire process is consequently crucial for the prevention of failure. This guide describes generically the extent of and the procedures for inspections to be performed at each stage of a marine vessel's life. Minor and major imperfections can be detected early in the construction process. Therefore, structural integrity can be maintained with periodic in-service inspections and appropriate and timely corrective measures to prevent any accumulation of defects or costly rework.

4.5 From construction and early service life inspections, a structural history of the vessel can be prepared forming the basis on which future in-service inspection results can be evaluated.

5. Inspection Considerations During Design Stages

5.1 To ensure the marine vessel's structural integrity, the designers should consider the following inspection-related requirements during the design stages:

5.1.1 *Inspectability of a Marine Vessel's Structure During Construction and In-Service:*

5.1.1.1 *Background*—During the life of any marine vessel, several inspections are conducted on the structure. These consist of two types that directly reflect their purpose, convenience and regulatory. In conducting either one, certain locations require access that are not readily accessible without climbing the structure or obtaining assistance from mechanical devices. When an inspection requires the use of mechanical means to access the structure, several options are available. They include anything from a simple platform elevated by a hoist connected at the overhead to a sophisticated ROV (Remote Operated Vehicle) that permits the inspector to remain outside the tank altogether. An issue that must be recognized is the degree of inspection. In other words, how close does one want to be to the structure, how accurate does the inspection need to be, and how long does one have to conduct the inspection. The definition of the "degree of inspection" has a direct bearing on the conclusions drawn from information presented herein.

5.1.1.2 For the purposes of this guide, the following assumptions are made relative to the degree of inspection:

5.1.1.3 The inspected structure must be in direct line of sight.

5.1.1.4 The inspected structure must be in clear and distinct view, taken as a distance of not more than 1.5 m (5 ft) from one's eyes.

5.1.1.5 The structure is to be inspected to a degree that would reveal almost all fractures that have a length of 50 mm (2 in.) or more. This depends significantly on the cleanliness, lighting level, stress, and so forth, of the structure.

5.1.1.6 The inspection shall be conducted in a continuous manner such that the shortest amount of time is taken for it.

5.1.1.7 For the purposes of inspection, the structure should be broken down into discrete zones, such as those depicted in Fig. 1. Where the structure differs from that depicted in Fig. 1, an appropriate scheme of identifying zones for inspection should be adopted.

(1) *Zone 1*—The bottom and inner bottom shell structure including the turn of bilge and any structure attached to them.

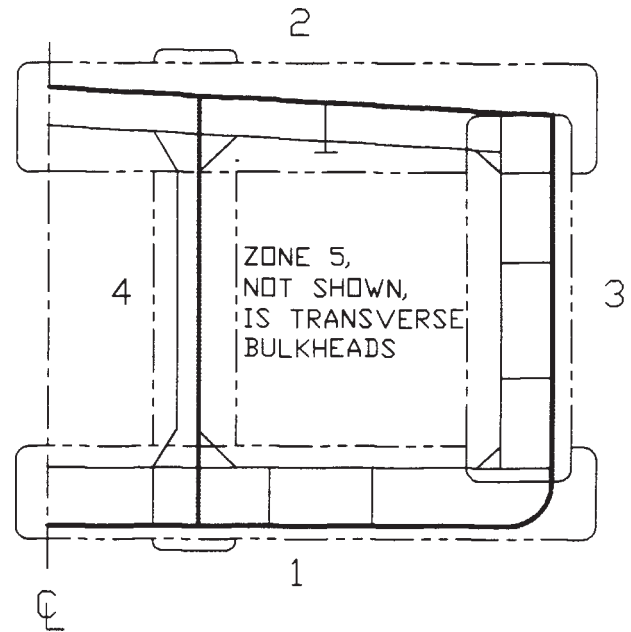

FIG. 1 Hull Girder Structure Areas Designated by Zones

(2) *Zone 2*—The deckhead structure, from ship's side to ship's side, including the stiffening attached to it.

(3) *Zone 3*—The side shell structure, including the side bulkhead structure for double hull vessels, including the stiffening attached to it.

(4) *Zone 4*—The longitudinal bulkhead structures that include the centerline and side longitudinal bulkheads, except a side bulkhead of a double hull structure.

(5) *Zone 5*—The transverse bulkhead structure, fore and aft sides, extending from the bottom shell to the deckhead.

5.1.2 *Access Methods:*

5.1.2.1 *Fixed Staging*—This method consists of poles, fittings, planks, and ladders that create a tower or walkway. This is the only method that permits access to all structural areas of a vessel. To achieve this coverage, however, it is very expensive and time consuming. A simple description of the method could be compared to an erector set. It is a straightforward method to which most people can relate. It may be a method that more people feel comfortable using than some. Accessing a deckhead structure that is 20 m (66 ft) or so above the bottom, however, is not a place for anybody with a fear of heights. This method has been a standard access method for conducting inspections and repairs to vessels for many years. The components are better designed and lighter in weight than ten or more years ago. Therefore, it is more easily constructed today.

5.1.2.2 *Portable Staging*—This method consists of a platform of sufficient size to carry at least one person. It also includes a winch that is attached to the platform. The wire on the winch is connected to the underdeck structure so that the platform raises towards the wire's connection point at the underdeck. The size of the platform varies. Some are sized to lift only one person while others are sized to lift up to four or five persons. In fact, some platforms are similar to those used by window washers—lightweight and breakdown for portability. For industrial applications, the staging is built more rugged

than typically used for window washers, such that the design load is higher. Persons on the staging should have individual safety harnesses attached to them. The Occupational Safety and Health Administration (OSHA) has become more active in verifying contractors perform their work in a safe manner. One high-risk aspect of using this staging is attaching the lifting wires to the overhead. This normally is accomplished by a person walking the deckhead. This person uses a set of stirrups each attached to one end of a short length of wire with some type of hook at the opposite end. The hooks fasten into the deckhead structure, then a person proceeds to walk across the deckhead while moving the stirrups and connecting the platform's lifting wires to the deckhead. OSHA has become more aware of this activity due to fatalities. They now require these persons to wear safety harnesses connected to lifelines. An alternate method of attaching the lifting wires to the overhead, but not normally used, is by drilling holes into the deck and passing wires through them. The wire end is then secured to provide a holding point. The problem is that drilling holes into a deck is not a desired situation. It can become a source of future fracture problems if not properly done and might be located in an area of high stress.

5.1.2.3 Rafting—This is a straightforward system and may be the easiest to understand. It consists simply of rowing around in a rubber raft while the water level in the tank is changed in height. This method has been used for many years, not only for inspection reasons, but also for access to upper regions of a tank by the vessel's crew for conducting repairs. In fact, there are various objects that can be used to provide buoyancy when access to high areas in a tank is needed and a rubber raft is not available. For structural inspections, normally two persons occupy a raft; this enhances the raft's maneuverability and the inspection. All areas of the structure can be accessed easily from the level of the liquid. Vessels with deep transverse structures, however, prohibit safely accessing the deckhead structure. If the water rises, it traps the raft's occupants between the structure and water level without a safe exit from the tank. This applies to any tank with a deckhead structure to some degree. An important aspect of this method relating to the thoroughness of an inspection is the rate of water level change. If the intervals are too great, such as 5 m (16.5 ft) or more, only those areas immediately above the water level are really surveyed close-up. This method can be implemented to inspect the structure continuously while changing the water level. The rate of level change can be controlled to permit sighting nearly 100 % of the accessible structure.

5.1.2.4 Climbing—This method often complements one of the other methods mentioned in the preceding sections. It varies from climbing the structure a short distance to see a particular location better, to climbing the height of the tank with the aid of a safety harness. The latter, although demonstrated, is not typically used. There are hazards when climbing any height; the higher one goes, the greater the risk of severe injury if one falls. Prudent judgment, therefore, is necessary to prevent accidents. This includes a decision to not climb to any height if the circumstances so indicate, for example, slippery conditions, physical problems, and so forth.

5.1.2.5 Other—The inspection methods here are not considered to be primary methods but rather ones that can support and enhance one or more of the methods previously described. They serve a specific purpose.

5.1.2.6 Ziggy—This mechanical device consists of a mechanism positioned above the deck that raises and lowers, and rotates from side to side, with a steel column constructed of short, rectangular tubes. The tubes are lowered through a butterworth hole to the bottom. A horizontal beam is attached to the bottom end of the column, and a single-person basket is attached to the other end of the beam. As the column is raised or lowered, the person in the basket can extend oneself to a distance between 3 and 9 m (10 and 30 ft) from the vertical column. This device permits one to inspect the side and underdeck structure without building a tower of staging, climbing the side shell, or filling the tank with water to the underdeck. It can be operated from the basket or from the deck positions.

5.1.2.7 Remote Operating Vehicle (ROV)—An ROV is similar to a miniature undersea, unmanned vehicle. This method also requires filling the tank with water. Unlike the rafting method, however, it is important to fill the tank as close to 100 % as possible. The ROV typically is sphere-like and has small, external propellers running inside ducts for maneuvering. They all include a camera. Some models are capable of doing additional operations other than viewing the tank internals, such as thickness gaging, cleaning off the surface, and varying the light intensity. An operator controls the ROV outside the tank at a control console. There is a monitor alongside to follow the maneuvers and to view the structure. A video tape of the whole inspection or parts thereof can be made. The communication link between the control panel and ROV is by cables connecting the two. It is important, therefore, to understand the compartment size and extent of inspection expected by the unit. The operator must understand the tank space where the ROV is operating. A knowledge of the internals, protruding obstacles, pipelines, and tank boundaries, therefore, is necessary to prevent the unit from becoming tangled in them.

5.1.2.8 Maricam—This unit could be considered a hybrid of the ROV and Ziggy methods. It consists of a high-resolution video camera mounted on a vertical column extended into the tank space from the deck. It too is remotely operated by two persons on deck who control the camera's movement, the light intensity, the lens' iris, zoom, and focus features; document suspect areas by video taping or manually logging the data; and monitor the video screen.

5.1.3 Identification of Telltale Areas in a Marine Vessel's Structure:

5.1.4 Determination of standard tolerances and acceptable levels for structural deviations on the basis of how they affect the structural performance as agreed upon by the owner, classification society, flag state, and shipyard

5.1.5 Selection of a corrosion protection system, such as coatings and cathodic protection, that will best protect the structure for the intended service under the maintenance plan. The selection of coatings should consider, in addition to

TABLE 1 Inspection Checklist for Primary Structures

	Proper Use of Materials	Dimensional Accuracy	Continuity	Alignment	Soundness of Welds	Distortion Deformation	Unfairness	Etc.
Bottom shell plate	VN*		V		VMN		VM*	
Side shell plate	VN*		V		VMN		VM*	
Deck plate	VN*		V		VMN			
Transverse bulkhead plate	VN*				VMN			
Longitudinal bulkhead plate	VN*		V		VMN			
Doublebottom plate	VN*		V		VMN			
Longitudinal frames	VN*	M	V	VM*	VMN	V		
Transverse frames or webs	VN*	M			VMN	V		
Longitudinal girders	VN*	M	V	VM*	VMN	V		
Floors	VN*	M	V	VM*	VMN			
Pillars/Stanchions	VN*	M			VMN			
—								
—								
—								
And so forth								

Legend:

V—Visual inspections

M—Physical measurements

N—NDT examinations

*—To be done only when visual inspections show that it is necessary.

protecting the structure, the ability to properly inspect the structure after a period of service.

5.2 *Inspectability*—In addition to the considerations of inspection methods in 5.1.1, the following precautions should be taken during design and preparation of detailed structural drawings:

5.2.1 Provide appropriate transverse and longitudinal member spacings and member depths to facilitate safe access.

5.2.2 Avoid blind spots in the structural arrangements.

5.2.3 Provide access plates or holes for entering tightly arranged structures. In addition to providing minimum sizes for openings, other considerations such as footholds, escape routes, alignment, and means of ventilation should be considered. In large tanks, catwalks should be considered in order to reduce the need for constructing staging for inspections. Resolution A.272(VIII), as amended by A.330(IX) (1),⁴ gives specific details for accessways for inspection.

5.2.4 Coordinating the selection of coating systems with the type of inspection program for the vessel. If removal of coatings will be necessary for random visual inspections, an acceptable program should be established in advance with the flag state and classification society.

5.2.5 Providing access to structural items subject to periodic in-service inspections, such as installing permanent rungs to facilitate access to otherwise uninspectable areas. These precautions could preclude the necessity of installing costly staging during in-service inspections.

5.2.6 The main objective is to ensure that structural design facilitates in-service and shipyard inspections. Toward this goal, a thorough review of structural design drawings to ensure proper consideration was given for structural inspections, which should be accomplished prior to structural fabrication.

5.2.7 Use of structural members that facilitate proper application of coating, such as bulb flats or flat bars, where access for coating application and corrosion removal is limited.

5.3 *Inspection Plan*—An inspection plan should be prepared for the vessel under design on the basis of analyses and investigations performed during the design stages. The plan should:

5.3.1 Provide accessibility instructions for parts to be inspected.

5.3.2 Identify telltale areas that should receive special attention during inspection activities. A separate set of plans should be included to identify these telltale areas. Specific inspection requirements should be given. NVIC 15-91 (2) includes in its enclosures (2) and (3) a breakdown of necessary information to document these telltale areas (referred to in this guide as “critical areas”).

5.3.3 Include a listing of all structural elements to be inspected, as well as the type and extent of inspections for each. A typical summary checklist for primary strength members is given in Table 1. This list should be expanded to cover all primary, secondary, and structural details, as applicable, to the specific vessel to be constructed.

5.3.4 Upon contract signing with a shipyard, the designer should list or reference the applicable standard used to develop structural tolerances and acceptable levels of deviation from these standards. The levels adopted should either be one of existing compilations or a modification of one suitable for use in negotiations with the prospective builders prior to signing a construction contract.

5.4 Guidance on standard tolerances and acceptable deviations can be obtained from classification society Rules, IHI SPAIS, Production Standards of the German Shipbuilding Industry, VIS 530 or SSC 213 (3, 4, 5, 6), as well as Guide F 1053/F 1053M. Most of these publications also contain recommended repair and corrective action procedures for major deviations from acceptable levels. These recommendations may be used as a baseline in determining the specific corrective action procedures to be adopted for the specific ship to be constructed.

⁴ The boldface numbers in parentheses refer to the list of references at the end of this standard.

6. Inspection Activities During Construction

6.1 By specifying preplanned inspections in excess of what is necessary to ensure structural integrity of the completed vessel, a burden is imposed on the shipyards, and therefore, results in costs and delays to the owners. On the other hand, by specifying and then conducting an insufficient amount of inspection, some deficiencies in the structure may remain undetected and may result in added repair or renewal operations. Accordingly, agreement is needed on a reasonably balanced level of inspection among the parties concerned (shipowner, shipyard, classification society, flag state, and designer). The aforementioned inspection plan can serve as the vehicle for this agreement.

6.2 *Owner's Needs:*

6.2.1 The owner of a vessel may need or desire to have conducted certain inspection activities and corrective measures that the shipyard may consider unnecessary or unwarranted from a structural strength viewpoint. An example is the desire of the owner of a high speed container ship to have all surface imperfections on the exterior hull plating, such as burrs, scars, spatter, removed even though these do not affect the ship's structural integrity and could be considered as cosmetic repair. Such removal, however, is important to the shipowner in light of operational efficiency.

6.2.2 The owner also may have a preference for the type and extent of nondestructive examinations (NDE) to be employed in construction inspections in excess of that required by class or flag state requirements. In such instances, this preference must be clearly stated in the specification.

6.2.3 All the needs expressed by the owner should be discussed by the concerned parties and agreed-upon procedures made a part of the construction inspection plan.

6.3 *Receipt Inspection of Materials:*

6.3.1 Consideration should be given to the inspection of structural material upon arrival at the shipyard's receiving area. Discussion with the class society, flag state authorities, the designer, and the shipyard should be conducted in order to determine any such inspection necessary, in addition to their requirements. Material certificates should always be confirmed with the material at delivery. Quality system procedures, in effect, may preclude intensive inspection with activity and record monitoring sufficing. During inspection of material, however, the following defects are those which must be spotted:

6.3.1.1 Deviations from nominal dimensions.

6.3.1.2 Surface defects, such as excessive pitting and flaking on plate and shape materials.

6.3.1.3 Laminations on plates.

6.3.1.4 Deviations from the specified type or grade of structural materials.

6.3.2 In order to detect these defects, visual inspections should be made and complemented by measurements for dimensional accuracy and by ultrasonic examinations to detect laminations as necessary. The extent of such examinations must be based on experience. In the last case, a review of mill certification for the plate is necessary.

6.3.3 Recommended tolerance standards and repair procedures for defects in excess of allowable levels are contained in

Guide F 1053/F 1053M, SSC 273, and JSOS–Hull Part (7, 8). Repair procedures or acceptance criteria, or both, should be developed with classification society and flag state concurrence.

6.3.4 By reviewing these references, the minimum receipt inspection requirements should be established and included in the ship's construction inspection program.

6.4 *Construction Inspections:*

6.4.1 In-process inspections should be performed by the shipyard production department supervisors as a self-inspection activity and by the quality assurance department inspectors for the purpose of assuring adequate control of quality during the ship construction process. The ship's construction inspection program also should include notations as to the elements of construction required to be inspected by flag state and classification society representatives.

6.4.2 The specified procedures, methods, and organizational roles may vary depending on the shipyard where the construction will take place and on the type and size of the vessel to be constructed. In any case, however, particular visual inspection functions should be accomplished during specific stages of construction.

6.4.3 Visual inspections during subassembly, assembly, and erection stages shall examine carefully the structure with specific attention to the following:

6.4.3.1 *Completeness*—To make sure that all of the major structural and production members on the subassembly/assembly/module/ship are in place as required by the detail design drawing or in accordance with good marine practice if all areas are not addressed in the drawings.

6.4.3.2 *Materials Used*—To verify that only the correct materials as specified by the detail design drawings are used. Material identification color codes or markings can be used for this verification.

6.4.3.3 *Accuracy*—To pinpoint apparent deviations from specified dimensions with the purpose of assuring that subassemblies and assemblies fit together. A preplanned dimensional program is necessary with the purpose of assuring that subassemblies and assemblies fit together. A preplanned dimensional verification program is necessary to accomplish this.

6.4.3.4 *Joint Preparation*—To ensure accuracy in fit-up, root openings, alignment of members, cleanliness, removal of slag, beveling, and so forth.

6.4.3.5 *Weld Layout*—This layout is used to determine that weld sizes are correct and that continuous or intermittent welds, or both, are being used in accordance with the detail design drawings. Full penetration welds should be inspected from both sides.

6.4.3.6 *Fairness*—To observe any noticeably excessive unfairness in the completed unit for the purpose of requiring fairness measurements if necessary.

6.4.3.7 *Structural Details*—To verify compliance with design drawings of structural details such as clearance cutouts, collars, brackets, stiffener end connections, and so forth.

6.4.3.8 *Supports/Braces*—To verify that an adequate quantity and quality of supports, braces, and lifting pads are provided and properly located for use in moving and handling

the unit without damaging it or disturbing it, or both, to the point that alignment requirements are exceeded.

6.4.3.9 *General Workmanship*—To see that the completed structural unit is free of discontinuities, undercuts, weld pockets, sharp ragged edges, nicks, or other damage that may initiate or propagate cracks. To verify that all temporary fabrication/erection attachments that are not required during later stages of construction are properly removed if desired by the owner.

6.4.4 Detailed structural drawings, construction specifications, and the inspection plan prepared during the design process are the specific guidelines for use in judging the acceptability of structures on the basis of visual inspections. A lot depends on the knowledge and experience of the inspector. Whenever the inspector is in doubt as to the acceptability of any part of the inspection criterion, the inspector should refer to the standard tolerances and acceptable deviations contained in SSC 273, JSOS-Hull Part (7, 8), Guide F 1053/F 1053M, or IHI SPAIS (3), the specification or those that may be included in the ship's inspection plan. If the inspector considers it necessary to have physical measurements or NDE made, the inspector should request them.

6.4.5 Dimensional accuracy and dimensional control activities should cover all stages of construction from mold loft to launching.

6.4.5.1 *Mold Loft*—Loft sheets, roll molds, furnace molds, and battens should be inspected for dimensional conformance and for completeness of detail with the latest revised detailed structural drawings. Steel tapes used in layouts and measurements shall be inspected periodically for accuracy.

6.4.5.2 *Plate Shop and Numerically Controlled Burning Area*—In order to verify conformance with detailed structural plans, the following should be inspected during plate preparation:

- (1) Orientation of plate with respect to the molded line.
- (2) Center punching of frames, buttocks, and waterlines for dimensional accuracy. The centerline of the ship should be used as a master reference line.
- (3) Spacings and angularities of structural members.
- (4) Verification of a sufficient final cut allowance.
- (5) Bevels and collars, final dimensions, alignment, and fairness, after the final cut.

6.4.5.3 *Subassembly/Assembly/Erection Areas*—The following dimensional accuracy inspections should be accomplished during panel and subassembly fabrication, assembly/unit/module construction, and erection processes in platen areas, pre-outfitting areas, and in building basins or shipways:

- (1) Orientation of plate with regard to the molded lines.
- (2) Spacing and dimensions of frames, stiffeners, girders, headers, and so forth.
- (3) Alignment and fairness, conformance of welds with detail plans and specifications.
- (4) Squareness and distortion.
- (5) Ship's principal dimensions (length, beam, depth).
- (6) Declivity and straightness of keel.

6.4.6 *Alignment and Fairness*—Excessive misalignment in structures may cause stress concentrations and, therefore, may lead to failure. Accordingly, alignment inspections should be

made during all stages of construction and any excessive, that is, beyond acceptable levels, deviations should be noted, recorded, and reported for research as to its root cause, so that appropriate corrective measures can be taken.

6.4.6.1 Essentially, the alignment measurements for plate edges and structural shapes should be made, after welding, on the following:

- (1) Shell assemblies, including transverse and longitudinal framing and floors.
- (2) Longitudinal and transverse bulkhead assemblies.
- (3) Strength decks.
- (4) Secondary structures, such as foundation, masts, rudders, tanks, trunks, and so forth.

6.4.6.2 Standard tolerances and acceptable levels for misalignment of various structural members are contained in SSC 273, JSQS-Hull Part, IHI SPAIS (3, 7, 8), or Guide F 1053/F 1053M.

6.4.6.3 The fairness of the plating, frames, beams, stiffeners, etc., should be checked and maintained within acceptable tolerances. Any unfairness found to be permissible should result in a generally fair curve across the plating panel or other structural members.

6.4.7 *Weld Inspections*—Weld inspections consist of visual surveys, physical measurements, and nondestructive examinations. Weld inspections should be performed no sooner than 24 h after the weld is completed and cool.

6.4.7.1 Weld inspections should be performed in the as-welded condition of the structure, that is, before coating. The weld to be inspected should be clean and all slag should be removed. Simple tools, such as a ruler, throat gage, undercut gage, or a fillet leg gage should be used in measurements to support visual examinations.

6.4.7.2 Tolerance standards and maximum levels of acceptance for welding defects shown as follows are contained, as are all other structural standards, in SSC 273, JSQS-Hull Part, IHI SPAIS (3, 7, 8), American Welding Society references, and classification society documents.

6.4.7.3 Methods, procedures, evaluation, and other requirements for NDE are provided by AWS, SSC-213, ABS (6, 9), and others.

6.4.7.4 Visual inspections and NDE examinations should be directed toward the detection of the following possible weld defects or deficiencies:

- (1) Errors in weld size per drawings.
- (2) Lack of fusion (NDE).
- (3) Undercuts.
- (4) Deviations from weld contour.
- (5) Fissures, cracks, or crack-like indications (NDE).
- (6) Porosity, NDE as well as visually.
- (7) Failure to wrap around fillet welds.
- (8) Visible evidence of arc strikes.
- (9) Sharp or ragged edges.
- (10) Excessive slag.
- (11) Slugged welds.
- (12) Incomplete welds.

6.4.8 *NDE*—NDEs should be performed according to the building specifications (detailed in the design inspection plan and as contained in the construction inspection program), and

the accompanying field sketches agreed upon by the shipowners, shipyard, and classification society surveyors.

6.4.9 *Final Structural Surveys and Tightness Tests*—Final structural surveys should be accomplished prior to completion of any unit, module, or the complete erection on the shipway. For all in-process inspections, but specifically for the joint final structural surveys, the preparation of the structure for inspection is very important.

6.4.9.1 During the final structural survey, all the structures should be inspected visually for completeness of all work, including attachments, penetrations, and all permanent access fittings and closures.

6.4.9.2 Tanks, compartments, cofferdams, and void spaces should be tested for tightness to prevent the spreading of flooding, fire, and gases. Tightness checks can be accomplished by means of hose tests, air pressure tests, hydrostatic tests, vacuum box tests, or weld boundary pressure tests. Tests should be carried out in accordance with a compartment testing diagram to be prepared by the shipyard's engineering department.

6.4.10 *Inspection by Classification Societies and Flag State Representatives*—These inspections ensure the vessel's structural integrity and its compliance with the rules and regulations from the standpoint of meeting minimum requirements.

6.4.10.1 Classification societies conduct their own inspections by resident surveyors during the vessel's construction period. At the end of the construction period, resident surveyors prepare and submit a surveyor report, which is used as one of the inputs for classification society decisions relating to acceptability of the vessel for classification.

6.4.10.2 Flag states also conduct inspections of marine vessels intended to operate under their registration during construction to ensure compliance with the applicable regulations. At the end of the inspection, a file is prepared containing some of the initial plans and design calculations, which also are used in decisions later in the life of the vessel.

6.5 *Common Structural Deficiencies:*

6.5.1 Many shipyards already have in-house publications for use in identifying most frequently encountered structural deficiencies and recommended corrective measures. Publicly available documents also exist for this purpose. Some of the references that contain common deficiencies, standard tolerances, and standard corrective measures are Guide F 1053/F 1053M, SSC 273, JSQS–Hull Part, IHI SPAIS, Production Standards of the German Shipbuilding Industry, and VIS–530 (3, 4, 5, 7, 8).

6.5.2 Some commonly encountered structural deficiencies are illustrated in Figs. 2-11, which should assist inspectors in identifying them during surveys:

- 6.5.2.1 Misalignment, Figs. 2 and 3.
- 6.5.2.2 Excessive gap between members, Fig. 4.
- 6.5.2.3 Stiffener tilt, Fig. 5.
- 6.5.2.4 Improper distance between adjacent welds, Figs. 6-8.
- 6.5.2.5 Weld flaws.
- 6.5.2.6 Weld undercut.
- 6.5.2.7 Distortion, Figs. 9 and 10.
- 6.5.2.8 Deformation of plate, Fig. 11.

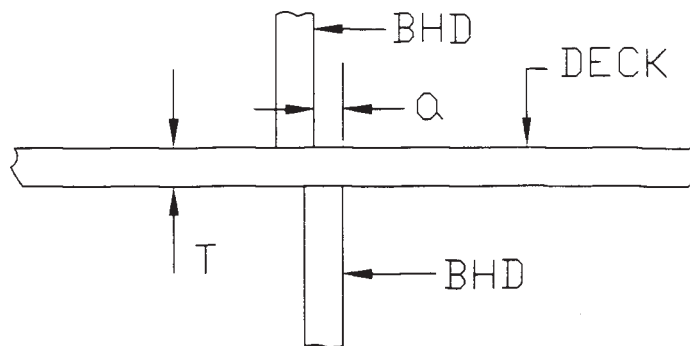

FIG. 2 Bulkhead Misalignment

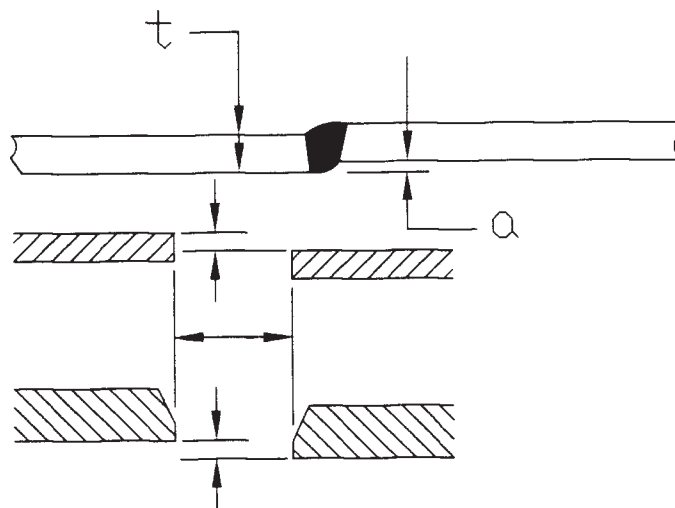

FIG. 3 Misalignment of Butt Connections

6.5.2.9 Cracks, dents, creases, and other damage.

6.6 *Recording/Reporting/Evaluation Procedures:*

6.6.1 Appropriate forms should be developed or adopted from similar forms used by others for requesting, recording, reporting (corrective action), analyzing, and processing structural inspections, and NDE. Caution should be used as forms developed and used by one shipyard may be different from those used by others, reflecting differences in the quality control organization. These forms should include the following information: record the inspection results, did the condition meet the specification, and, if not, what must be done to correct the situation, including requested assistance from outside bidders.

6.6.2 *Dissemination of Inspection Results:*

6.6.2.1 Findings from inspection activities, as they relate to specific parts of the ship's structure, should be recorded on appropriate forms and maintained in the owner's, ship's, shipyard's, or class society's inspection file. Applicable forms should be distributed to the proper departments in the shipyard, to the owner's representatives, and to classification society surveyors for review and execution or approval of the recommended corrective action. Each of these is a separate activity, but all in support of the owner.

6.6.2.2 Most important is the feedback of inspection results to the structural designer. By being aware of the deficiencies found and the corrective actions accomplished on the structure,

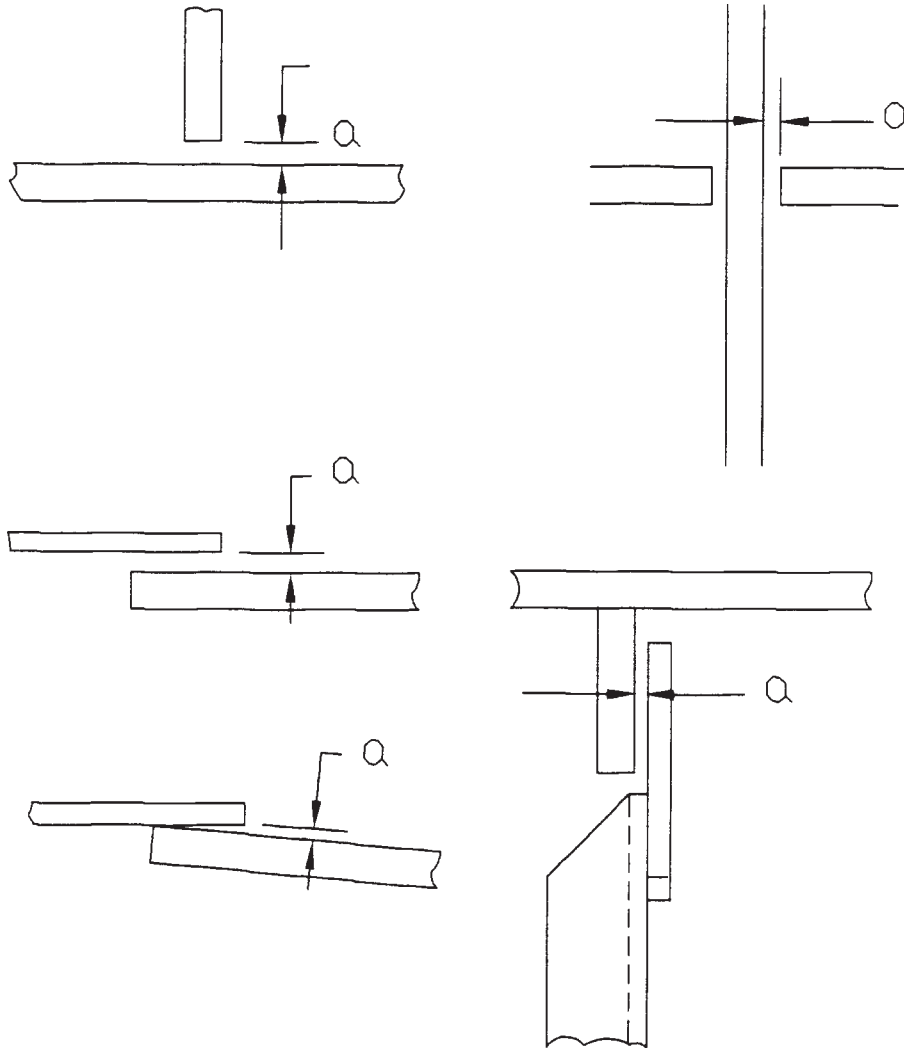

FIG. 4 Excessive Gap Between Members

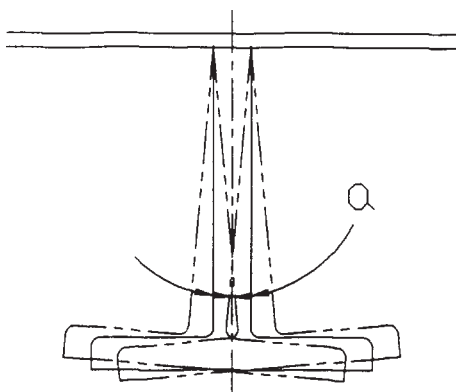

FIG. 5 Stiffener Tilt

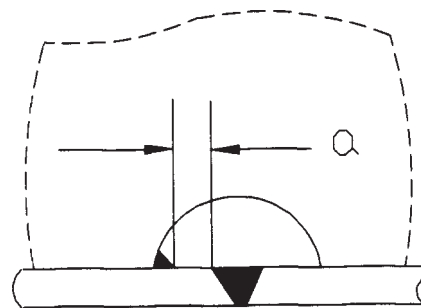

FIG. 6 Improper Distance Between Butt Weld and Scallop

the designer can analyze the causes and consequences of the deficiency, decide whether the corrective action was sufficient, and determine if the original design should be modified to prevent recurrence of similar deficiencies in follow-on constructions. If such information is proprietary to the owner, the owner should provide such information to the designer.

6.6.2.3 Maintaining brief but clear records of all structural deficiencies and repairs will enable the shipyard to determine the as-built condition of the marine vessel's structure.

6.7 A thorough review and analysis of all structural inspection reports and deficiency/corrective action records will enable the shipyard to prepare a structural history of the ship's construction and the condition of its structure as built. This information should be compiled into a complete "Structure Condition Record" for use as a reference basis throughout the ship's service life. It should record:

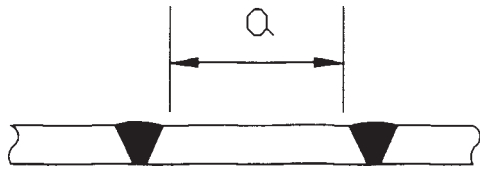

FIG. 7 Improper Distance Between Adjacent Butt Welds

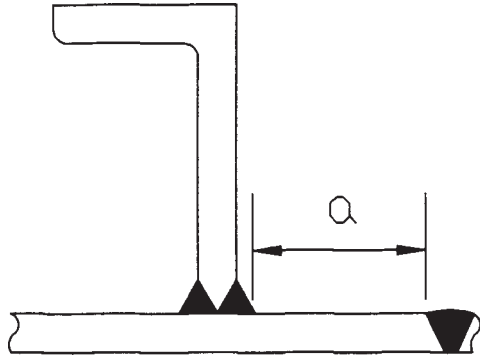
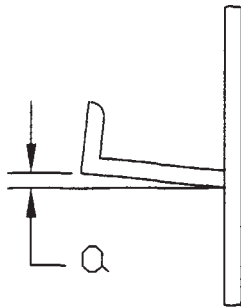

FIG. 8 Improper Distance Between Butt Weld and Fillet Weld



SEC. A-A

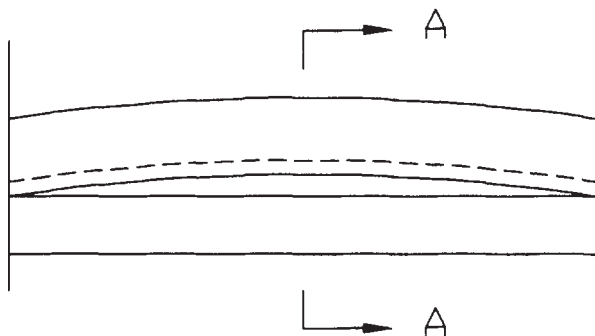

FIG. 9 Distortion of Beams, Frames, and Stiffeners

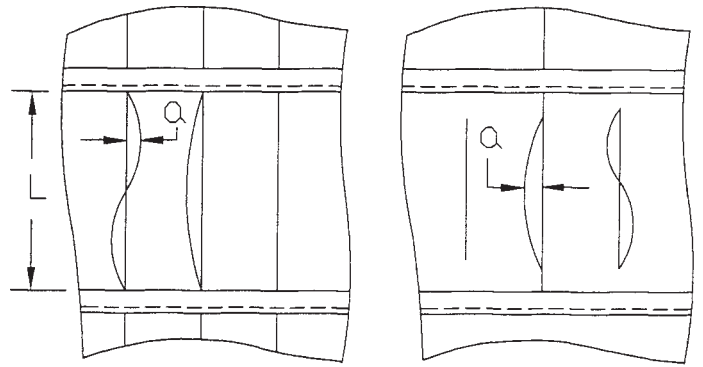

FIG. 10 Distortion in Panel Stiffeners

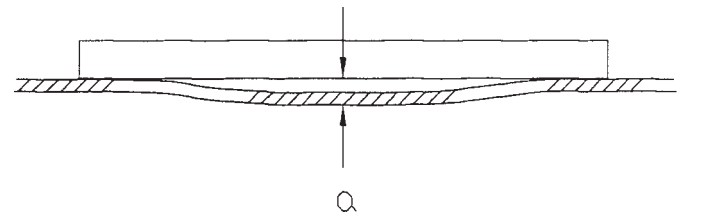

FIG. 11 Deformation of Plate

6.7.3 Structure found to have deviations larger than allowable levels, but jointly accepted by yard, owner, classification society, and flag state inspectors as not requiring corrective action.

6.7.4 The extent of actual deviations for these structures or structural elements. Structures found to have unacceptable deviations but repaired using standard corrective action procedures.

6.7.5 Structure found to have unacceptably large deviations for which the original design had to be modified to avoid recurrences of deficiencies.

7. Preparation of In-Service Inspection Program

7.1 At the end of a ship's construction period, the "Design Inspection Plan," the "Construction Inspection Program," and the "Structure Condition Record" should be prepared for structural inspections to be performed during the vessel's operating life. This guide should reconcile the three aforementioned documents and include the following:

7.1.1 Identification of telltale areas as determined in the "Design Inspection Plan."

7.1.2 Any changes to telltale areas due to built-in material deficiencies or accepted fabrication errors during the construction process.

7.1.3 Other significant areas for inspection, not due to design allowance, but due solely to material or fabrication errors, or both, during construction.

7.1.4 Prepare an inspection checklist based on the preceding considerations identifying all structures to be subjected to in-service inspections. The inspection checklist should include:

7.1.4.1 Inspection frequencies.

7.1.4.2 Methods and procedures for inspections.

7.1.4.3 Tools and equipment to be used.

7.1.4.4 Responsibilities for performance of inspections, that is, whether to be conducted by the owner's representatives

6.7.1 All inspected structure found to be within acceptable tolerances.

6.7.2 The actual accepted tolerances, or deviations from standard, for the structures.

while vessel is in service, by a shipyard crew while afloat, or by the yard crew during drydocking, and so forth.

7.1.4.5 Cargo to be carried.

7.1.4.6 Marine vessel's service.

7.1.4.7 History of prior in-service inspections.

7.2 *In-Service Inspections:*

7.2.1 *General:*

7.2.1.1 The condition of the ship's structure should be kept under constant surveillance by situational and periodical inspections throughout its operating life in accordance with an in-service inspection program. This plan is prepared during final stages of the construction period and should take into account necessary flag state- and classification-society required inspection and surveys.

7.2.1.2 Structural inspections conducted between those required by the flag state or classification society must be based on decisions by the owner, and it is his responsibility to provide trained personnel to conduct the inspections while the vessel is in service. Some periodic inspections may be performed by the crew, but some would require preparations or training beyond normally expected crew capabilities.

7.2.1.3 The in-service inspection program prepared during the construction period should include, among other things, the identified telltale areas for which the owner's representatives should perform interim inspections. The program also should have flagged those structures that are considered significant due to design features or fabrication history, that is, built-in material/fabrication/workmanship variations.

7.2.1.4 The in-service inspection program should be updated during the vessel's life to reflect the extent of coatings breakdown, service in which the vessel is operated, and how the structure has withstood that service. As problems develop during the life of the vessel, standard repair procedures for recurring problems should be developed and entered into the inspection program for the specific details. In subsequent inspections, these repairs should be inspected to verify that they have solved the preexisting problem. Repair procedures should be developed with classification society and flag state concurrence.

7.2.2 *Owner's Representatives Inspection:*

7.2.2.1 In general, owner's representatives will have some opportunity to inspect the structure while at sea. These inspections may reveal deterioration or damage to parts of the structure that may be repaired by the crew, riding maintenance persons, or if more detailed inspection and repair is needed, possibly in a shipyard. In some cases, parts of the ship's structure may be uninspectable while at sea because the structure may be inaccessible due to existence of fuel, water, cargo, insulation, and so forth, in the spaces to be inspected. In this case, the owner should plan ahead for yard inspections.

7.2.2.2 Owner representatives' inspections, when possible, can accomplish the following:

- (1) Detect and repair minor damage and deterioration.
- (2) Obtain an early warning of major structural problems.
- (3) Keep corrosion control systems under surveillance.
- (4) Identify areas for detailed surveys and plan and budget for shipyard availability.

(5) By doing all of the preceding, reduce overall survey and repair costs.

7.2.2.3 Some of the typical structural flaws that the owner's representatives can detect are:

- (1) Scale formation on plates and shapes.
- (2) Pitting.
- (3) Localized wastage.
- (4) Resultant loss of thickness.
- (5) Wastage of zinc anodes in tanks, if used.
- (6) Poor condition of coatings.
- (7) Buckling in structural members.
- (8) Fractures, cracks.
- (9) Other obvious damage, such as dents, creases, and so forth.

7.2.2.4 In addition to main structural elements, inspections also should cover miscellaneous structures, such as handrails, ladders, platforms, valve reach rods, and so forth.

7.2.2.5 Enhanced surveys of main structural members inspected by the owner's representatives with the concurrence of the class society, to the extent possible, should include deck plating, underdeck girders and longitudinals, side shell plating and framing, transverse and longitudinal bulkheads with their stiffeners, and stringer platforms, if any, as well as other areas of concern as determined by IMO, IACS, or the particular class society or flag state.

7.2.2.6 Figs. 11-22 show some typical structural deficiencies, such as, fractures, buckling, and deterioration, that can be detected by owner representative's inspections. These sketches are applicable to the design of a tanker. Similar sketches should be developed for the specific ship to be inspected and included in the in-service inspection program. The Tanker Structure Cooperative Form Guidance Manuals (10) are especially good sources for graphical representations.

7.2.3 *Periodic Inspection by Classification Societies and Port and Flag State Representatives*—These bodies conduct inspections of the marine vessel's structure in accordance with well-established procedures requirements. It is the owner's

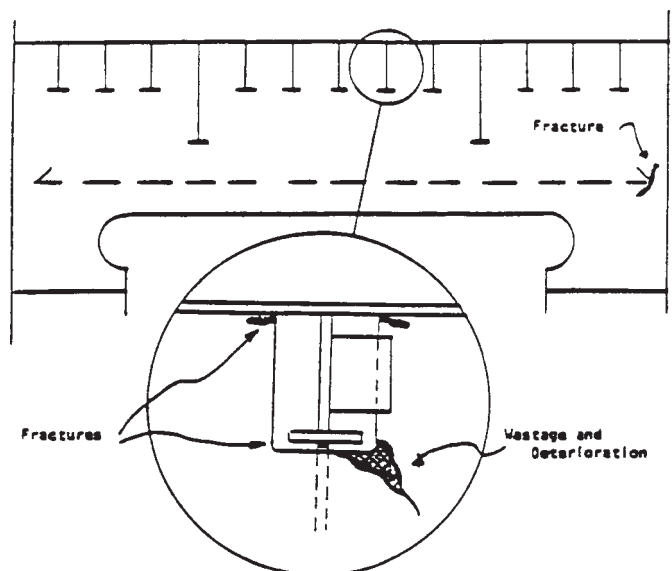

FIG. 12 Horizontal Stringer in Wing Tanks

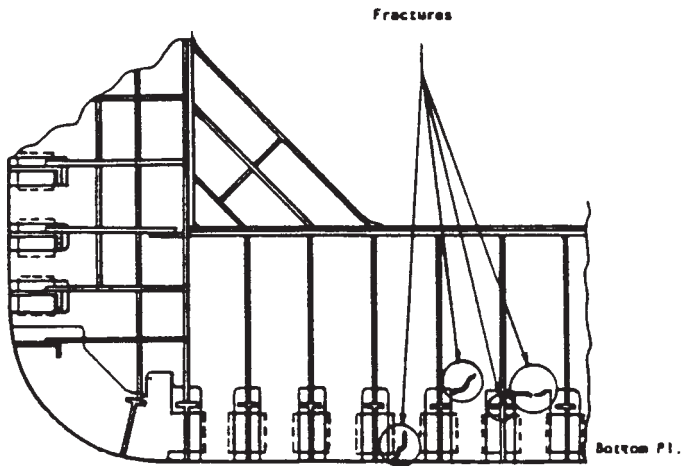

FIG. 13 Transverse Web Frame at Bottom

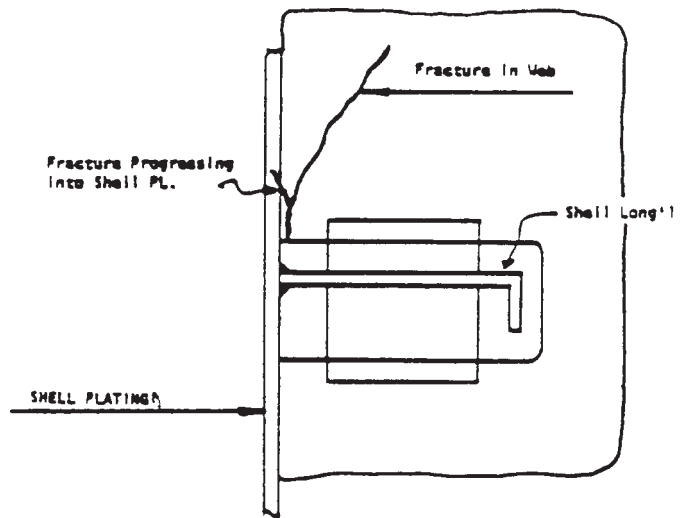

FIG. 16 Combined Progressive Shell Plate and Transverse Web Frame Fracture

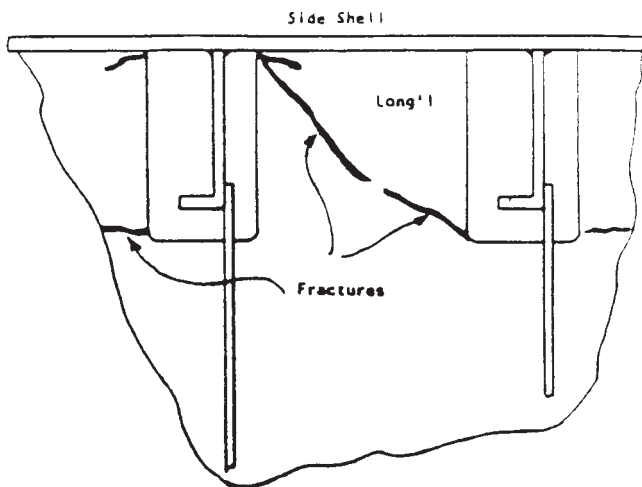

FIG. 14 Transverse Web Frame at Side Shell

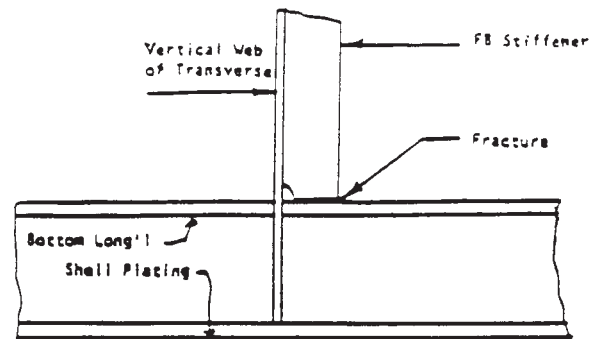

FIG. 17 Fracture in Bottom Transverse Web

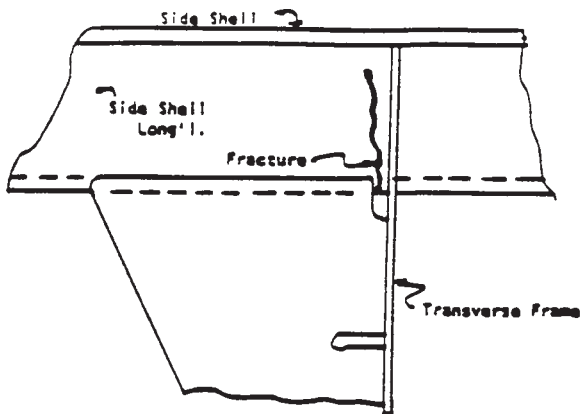

FIG. 15 Side Shell Longitudinal Fracture

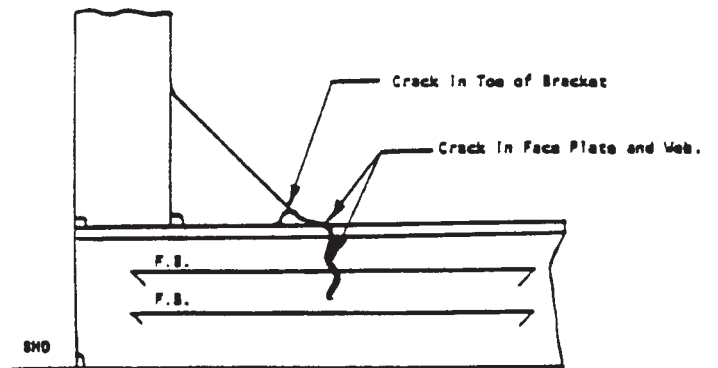

FIG. 18 Fracture in Longitudinal Intercostal Girder

responsibility to ensure the vessel is properly maintained. Sole reliance on these bodies' minimum periodic inspections is not judicial. Typical procedures and frequencies are described in detail in the classification society rules as applicable to vessels of varying types and by flag state requirements.

7.2.4 Repair and Conversion Inspections:

7.2.4.1 The procedures to be followed in performing structural inspection for and during major repairs and overhaul

availabilities, essentially, are combinations of construction and in-service inspection procedures. The repairs to any structure due to damage or deterioration should follow established repair procedures contained in the in-service inspection program. Whenever the damage is so extensive that removal of the existing structure and renewal with new materials is required, the construction inspection program requirements should be observed.

7.2.4.2 When alterations are to be made to the existing structure as necessitated by a conversion design, the areas to be modified should be structurally inspected in accordance with

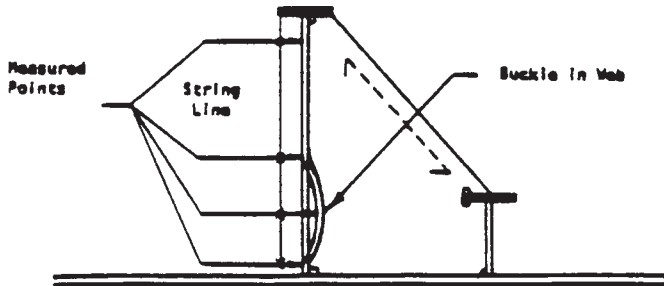

FIG. 19 Buckling of Centerline Girder

in-service inspection requirements. The newly constructed parts or additional structures should be inspected in accordance with new construction requirements.

7.2.4.3 Special attention should be given to the continuity and compatibility of structures and materials for major structural renewals and for structural modifications or additions, or both.

7.2.5 Maintaining and Updating the Structure Condition Record:

7.2.5.1 The Structure Condition Record (SCR) prepared at the end of the construction period should be referred to before initiating periodic in-service inspection activities, even if the specific requirements from it have already been incorporated into an In-Service Inspection Program. The SCR should have descriptive background information to enable structural inspectors to understand better the reasons for special inspection requirements for the specific parts of the structure.

7.2.5.2 The SCR should be kept current by modifying the existing data or by adding new data, as applicable, from the results of any in-service inspections or any corrective measures, or both, taken on the basis thereof.

8. Keywords

8.1 crack; damage; defect; dent; details; distribution; examination; failure; flaws; fracture; inspection; nondestructive; structures; welds

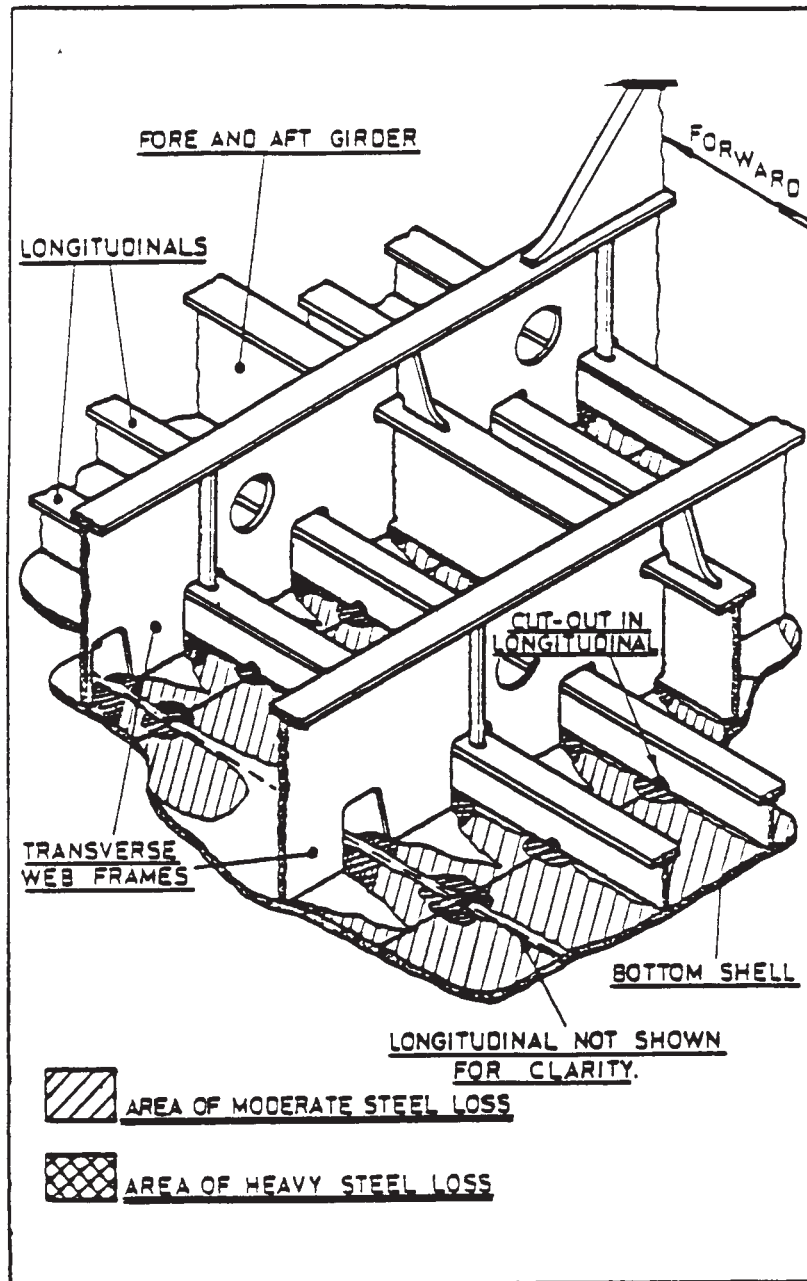

FIG. 20 Typical Bottom Shell Loss Patterns

Reproduced by special permission from "Large Oil Tanker Structural Survey Experience" by Exxon Corporation Tanker Department, June 1982.

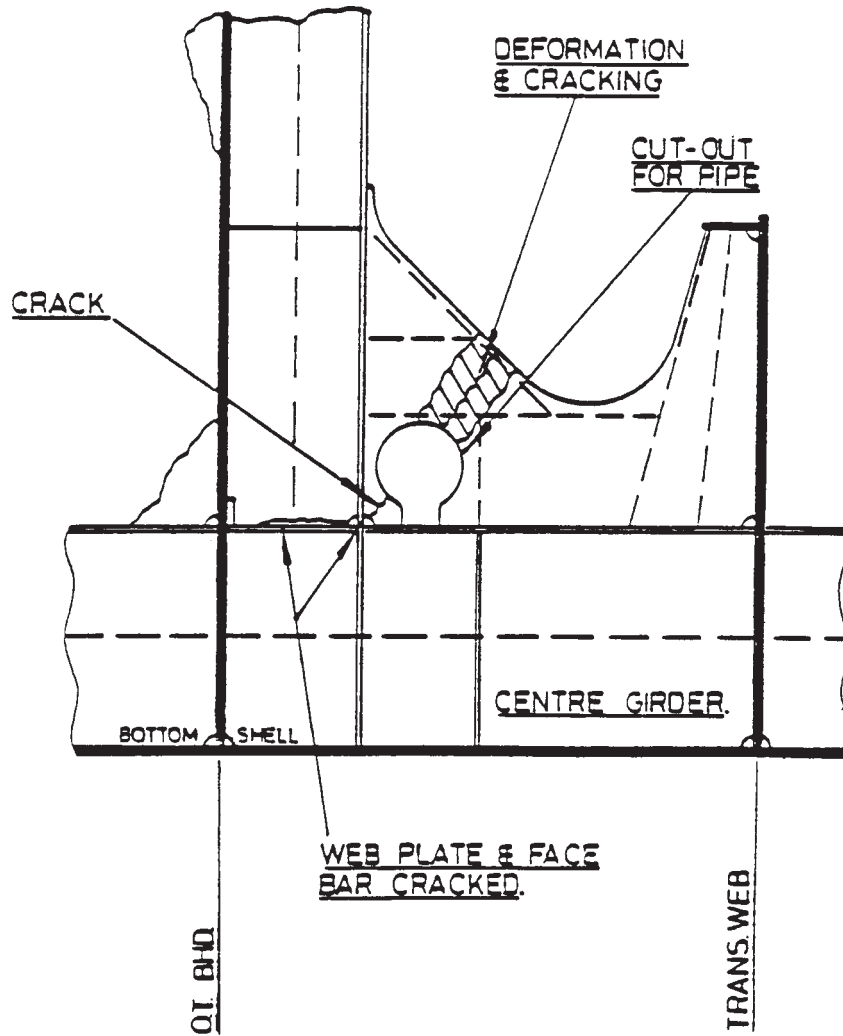

FIG. 21 Center Girder Cracking

Reproduced by special permission from "Large Oil Tanker Structural Survey Experience" by Exxon Corporation Tanker Department, June 1982.

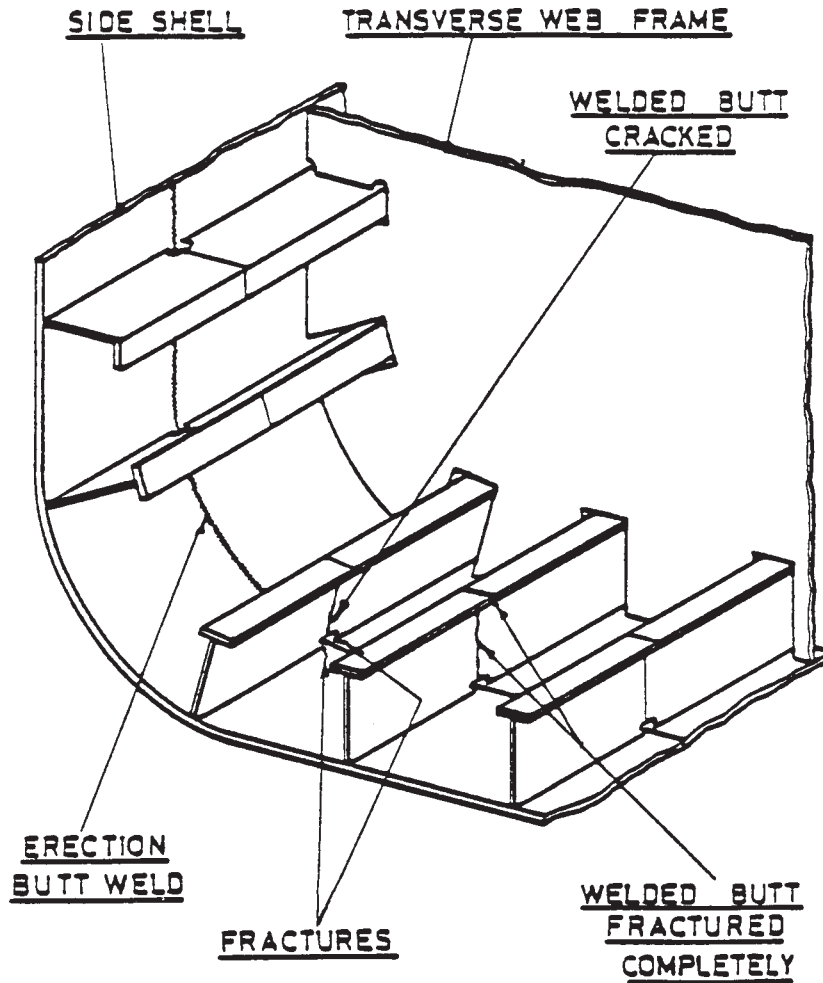



FIG. 22 Typical Bottom Longitudinal Cracking

REFERENCES

- (1) Resolution A.272(VIII) Recommendations on Safe Access to and Working in Large Tanks, and Recommendations on Safe Access to and Working in Large Cargo Holds of Bulk Carriers, International Maritime Organization (IMO), 1973 (Amended by Resolution A330(IX)).
- (2) NVIC (Navigation and Vessel Inspection Circular) 10-82, United States Coast Guard, Washington, DC, 18 May 1982.
- (3) IHI SPAIS—The Shipbuilding Process and Inspection Standard, Ishikawajima-Harima Heavy Industries Co., Ltd., Japan, 1980.
- (4) Production Standards of the German Shipbuilding Industry, Association of German Shipbuilding Industry, Hamburg, 1974.
- (5) VIS 530—Accuracy in Hull Construction, Varvindustrins Standardcentral, Stockholm, 1976.
- (6) SSC-213—A Guide for Ultrasonic Testing and Evaluation of Weld Flaws, Youshaw, Ship Structure Committee, 1970.
- (7) SSC-273—Survey of Structural Tolerances in the U.S. Commercial Shipbuilding Industry, Basar, N.S. and Stanley, R.F., Ship Structures Committee, 1978.
- (8) JSQS (Japanese Shipbuilding Quality Standard)—Hull Part, SNAJ Publication, Tokyo, 1975.
- (9) *Rules for Nondestructive Testing of Hull Welds*, American Bureau of Shipping, New York, NY.
- (10) *Guidelines Manual for Tanker Structures*, Tanker Structure Cooperative Forum (TSCF) and *Guidelines for the Inspection and Maintenance of Double Hull Tankers*, Tanker Structure Cooperative Forum (TSCF), Witherby & Co., Ltd., 32/36 Aylesbury Street, London EC1R 0ET, England.
- (11) *Rules for Building and Classing Steel Vessels*, American Bureau of Shipping, New York, Latest Edition.
- (12) *Rules for Building and Classing Steel Vessels, Part 1*, Appendix 1/B, Hull Surveys of Oil Tankers, American Bureau of Shipping, Latest Edition.
- (13) SSC-332—Guide for Ship Structural Inspections, Basar, N.S. and Jovino, V.W., Ship Structure Committee, 1978.

 **F 1754 – 97 (2004)**

ASTM International takes no position respecting the validity of any patent rights asserted in connection with any item mentioned in this standard. Users of this standard are expressly advised that determination of the validity of any such patent rights, and the risk of infringement of such rights, are entirely their own responsibility.

This standard is subject to revision at any time by the responsible technical committee and must be reviewed every five years and if not revised, either reapproved or withdrawn. Your comments are invited either for revision of this standard or for additional standards and should be addressed to ASTM International Headquarters. Your comments will receive careful consideration at a meeting of the responsible technical committee, which you may attend. If you feel that your comments have not received a fair hearing you should make your views known to the ASTM Committee on Standards, at the address shown below.

This standard is copyrighted by ASTM International, 100 Barr Harbor Drive, PO Box C700, West Conshohocken, PA 19428-2959, United States. Individual reprints (single or multiple copies) of this standard may be obtained by contacting ASTM at the above address or at 610-832-9585 (phone), 610-832-9555 (fax), or service@astm.org (e-mail); or through the ASTM website (www.astm.org).