



Standard Specification for “Twist Off” Type Tension Control Structural Bolt/Nut/Washer Assemblies, Steel, Heat Treated, 120/105 ksi Minimum Tensile Strength¹

This standard is issued under the fixed designation F 1852; the number immediately following the designation indicates the year of original adoption or, in the case of revision, the year of last revision. A number in parentheses indicates the year of last reapproval. A superscript epsilon (ε) indicates an editorial change since the last revision or reapproval.

1. Scope*

1.1 This specification covers two types of heat treated, steel, tension control bolt-nut-washer assemblies, also referred to as “sets.” These assemblies are capable of developing a minimum predetermined tension when installed by applying torque to the nut, while at the same time applying a counter torque to separate the spline end from the body of the bolt using an appropriate spline drive installation tool.

1.2 An assembly consists of a tension control bolt with spline end (covered by this specification) and a suitable nut and washer covered by reference to applicable ASTM specifications.

1.3 The fastener assemblies are intended for use in structural connections. These connections, installation procedures, and the use of alternate design structural bolts are covered under the requirements of the “Specification for Structural Joints Using ASTM A 325 or A 490 Bolts,” approved by the Research Council on Structural Connection.

1.4 The assemblies are available with either round (button or dome) heads, heavy hex structural heads, or alternate design heads described in Section 10 and Fig. 1, in sizes ½ to 1 ⅞ in. inclusive, in two types specified in Section 4.

1.5 Terms used in this specification are defined in Terminology F 1789 unless otherwise defined herein.

1.6 The following precautionary statement pertains only to the test method portions, Sections 13 and 14, of this Specification: *This standard does not purport to address all of the safety concerns, if any, associated with its use. It is the responsibility of the user of this standard to establish appropriate safety and health practices and determine the applicability of regulatory limitations prior to use.*

2. Referenced Documents

2.1 ASTM Standards:²

- A 29/A 29M Specification for Steel Bars, Carbon and Alloy, Hot-Wrought and Cold-Finished, General Requirements for
- A 194/A 194M Specification for Carbon and Alloy Steel Nuts for Bolts for High Pressure or High Temperature Service, or Both
- A 242/A 242M Specification for High-Strength Low-Alloy Structural Steel
- A 325 Specification for Structural Bolts, Steel, Heat Treated, 120/105 ksi Minimum Tensile Strength
- A 563 Specification for Carbon and Alloy Steel Nuts
- A 588/A 588M Specification for High-Strength Low-Alloy Structural Steel with 50 ksi [345 MPa] Minimum Yield Point to 4-in. [100-mm] Thick
- A 709/A 709M Specification for Carbon and High-Strength Low-Alloy Structural Steel Shapes, Plates, and Bars and Quenched-and-Tempered Alloy Structural Steel Plates for Bridges
- A 751 Test Methods, Practices, and Terminology for Chemical Analysis of Steel Products
- A 871/A 871M Specification for High-Strength Low-Alloy Structural Steel Plate With Atmospheric Corrosion Resistance
- B 695 Specification for Coatings of Zinc Mechanically Deposited on Iron and Steel
- D 3951 Practice for Commercial Packaging
- F 436 Specification for Hardened Steel Washers
- F 606 Test Methods for Determining the Mechanical Properties of Externally and Internally Threaded Fasteners, Washers, and Rivets
- F 788/F 788M Specification for Surface Discontinuities of Bolts, Screws, and Studs, Inch and Metric Series
- F 1470 Guide for Fastener Sampling for Specified Mechanical Properties and Performance Inspection

¹ This specification is under the jurisdiction of ASTM Committee F16 on Fasteners and is the direct responsibility of Subcommittee F16.02 on Steel Bolts, Nuts, Rivets and Washers.

Current edition approved Jan. 1, 2004. Published January 2004. Originally approved in 1998. Last previous approved in 2002 as F 1852–02.

² For referenced ASTM standards, visit the ASTM website, www.astm.org, or contact ASTM Customer Service at service@astm.org. For *Annual Book of ASTM Standards* volume information, refer to the standard’s Document Summary page on the ASTM website.

*A Summary of Changes section appears at the end of this standard.

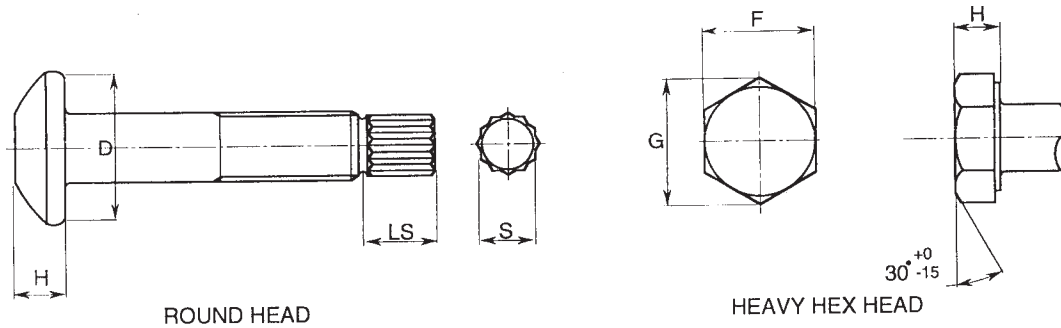

DIMENSIONS FOR TWIST OFF STRUCTURAL BOLT

NOMINAL SIZE OR BASIC PRODUCT DIAMETER	F		G		D	H		LS	S	
	WIDTH ACROSS FLAT		WIDTH ACROSS CORNERS		BEARING SURFACE DIAMETER	HEIGHT		LENGTH OF SPLINE	WIDTH ACROSS FLATS	
	MAX	MIN	MAX	MIN	MIN	MAX	MIN	REF.	REF.	
1/2"	0.500	0.875	0.850	1.010	0.969	0.890	0.323	0.302	0.50	0.32
5/8"	0.625	1.062	1.031	1.227	1.175	1.102	0.403	0.378	0.60	0.43
3/4"	0.750	1.250	1.212	1.443	1.383	1.338	0.483	0.455	0.65	0.53
7/8"	0.875	1.438	1.394	1.660	1.589	1.535	0.563	0.531	0.72	0.61
1"	1.000	1.625	1.575	1.876	1.796	1.771	0.627	0.591	0.80	0.70
1-1/8"	1.125	1.812	1.756	2.093	2.002	1.991	0.718	0.658	0.90	0.80
	A		A			A		B	B	

- A These values are the same as the dimensions for Heavy Hex Structural Bolts specified in ANSI B18.2.1.
- B The spline length (LS) and across the flat (S) dimensions are used for reference only. The grooved spline design may vary in size and shape.

NOTE 1—ANSI/ASME Subcommittee B 18.2.1 is currently preparing an American Standard to cover dimensional requirements for this product. Upon publication, these dimensions will be replaced with a reference to the American Standard for the dimensional requirements.

FIG. 1 Head and Spline Dimensions Inches

- F 1789 Terminology for F16 Mechanical Fasteners
- G 101 Guide for Estimating the Atmospheric Corrosion Resistance of Low-Alloy Steels
- 2.2 ANSI/ASME Standards:
 - ASME B1.1 Unified Screw Threads³
 - ANSI B18.2.1 Square and Hex Bolts and Screws³
 - ANSI B18.18.3M Inspection and Quality Assurance for Special Purpose Fasteners³
- 2.3 Research Council on Structural Connections Specification for Structural Joints Using ASTM A 325 or A 490 Bolts⁴

3. Terminology

3.1 Definitions of Terms Specific to This Standard:

³ Available from American National Standards Institute (ANSI), 25 W. 43rd St., 4th Floor, New York, NY 10036

⁴ Available from American Institute of Steel Construction (AISC), One E. Wacker Dr., Suite 3100, Chicago, IL 60601-2001.

3.1.1 *assembly lot*—an assembly lot for purposes of assigning identification numbers and from which test samples shall be selected, shall consist of one combination of component lots. That is, one tension control bolt component lot, one nut component lot, and one washer component lot which are shipped as an assembly.

3.1.2 *component lot*—A component lot, for the purpose of assigning an identification number and from which test samples shall be selected, shall consist of all tension control bolts, all nuts or all washers processed essentially together through all operations to the shipping container, of which each component has the following common characteristics: heat number (mill heat); ASTM designation and grade or type, as applicable; nominal dimensions (size) and head style; heat treatment lot; and coating lot, if applicable.

3.1.3 *secondary processing*—any processing performed by any entity on the assemblies or individual components after initial testing.

3.1.4 *tension control bolt*—a bolt that includes an integral spline end which extends beyond the threaded portion of the bolt. The fastener is to be tightened using a special electric wrench and socket system which has an inner socket that engages the spline end and with an outer socket that engages and turns the nut.

3.1.5 *tension control bolt assembly*—a tension control bolt, nut and washer combination.

4. Classification

4.1 The tension control bolts are designed by type denoting chemical composition as follows:

4.1.1 *Type 1*—Plain carbon, carbon boron, or alloy steel.

4.1.2 *Type 3*—Weathering steel. Atmospheric corrosion resistance and weathering characteristics are comparable to that of steels in Specifications A 242/A 242M, A 588/A 588M, A 709/A 709M, A 871/A 871M, (see 7.1.2).

5. Ordering Information

5.1 Orders for assemblies shall include the items of information below. Optional items not on the purchase order shall be considered as not being required, (see Note 1):

5.1.1 Quantity of assemblies

5.1.2 Size, include nominal tension control bolt diameter and length (without the spline end)

5.1.3 Name of product, that is, twist off type tension control bolt/nut/washer assemblies,

5.1.4 Head Style (see 10.1.1),

5.1.5 Type of Assembly, that is; Type 1 or Type 3

5.1.6 ASTM designation and year of publication,

5.1.7 Mechanically zinc coated, if required, and

5.1.8 Special requirements, if required

NOTE 1—A typical order description follows: 2520 assemblies, 3/4 in. diameter by 2 in. long Tension Control Bolt/Nut/Washer Assemblies, Round Heads, Type 1 ASTM F 1852.

6. Materials and Manufacture

6.1 *Heat Treatment:*

6.1.1 Tension control bolts made from carbon or carbon boron steel shall be heat treated by quenching in a liquid medium from above the austenitizing temperature and then tempering by reheating to a temperature of at least 800°F (425°C).

6.1.2 Tension control bolts made from alloy steel shall be heat treated by quenching in oil from above the austenitizing temperature and then tempering by reheating to a temperature of at least 800°F (425°C).

6.2 *Thread*—The threads of tension control bolts shall be rolled.

6.3 *Mechanical Zinc Coating:*

6.3.1 When zinc coating is specified, each component of the assembly shall be mechanically zinc coated. The coating shall conform to Specification B 695, Class 50 Type 1 as a minimum thickness.

6.3.2 Hot dip zinc coating shall not be permitted.

6.4 *Lubrication*— All nuts, plain and zinc coated, shall be lubricated. The lubricant shall be clean and dry to the touch.

NOTE 2—No further lubrication shall be permitted other than that

applied by the manufacturer, as the type and amount of lubrication is critical to performance.

6.5 *Secondary Processing:*

6.5.1 If heat treatment, zinc coating, lubrication or other processing affecting properties are performed by any source on any unit of a component lot after the manufacturer's test to qualify a lot has been performed, the component lot shall be treated as newly manufactured and shall be reinspected and retested in accordance with the requirements of its original manufacturing specification after such processing is completed. Retesting shall be the responsibility of the party supplying the component.

6.5.2 Secondary processing shall not be permitted to an assembly lot.

6.6 *Assembly:*

6.6.1 The assemblies shall be of the type specified by the purchaser.

6.6.2 The assemblies shall consist of one tension control bolt, with one lubricated nut and one or more washer(s).

6.6.3 Unless otherwise specified, nuts and washers used on the assemblies shall conform to the requirements of the specifications below:

Assembly Type and Finish	Nut Specification, Class and Finish	Washer Specification, Type and Finish
Type 1 Plain	A 563 DH Plain A 194 2H Plain A 563 C Plain	F 436 Type 1 Plain
Type 1 Mech. Zinc Coated	A 563 DH Mech. Zinc Coated	F 436 Type 1 Mechanical Zinc Coated
Type 3 Plain	A 563 DH3 Plain A 563 C3 Plan	F 436 Type 3 Plain

6.6.4 All nuts shall be Heavy Hex. All washers used in the assembly shall be circular and through hardened.

7. Chemical Composition

7.1 *Tension Control Bolts:*

7.1.1 Type 1 tension control bolts shall be plain carbon steel, carbon boron steel, or alloy steel, at the manufacturers option, and shall conform to one of the chemical compositions specified in Table 1.

7.1.2 Type 3 tension control bolts shall be weathering steel and shall conform to one of the chemical compositions, specified in Table 2. The selection of the chemical composition A, B, C, D, E, or F, shall be at the option of the manufacturer. See Guide G 101 for method of estimating the atmospheric corrosion resistance of low alloy steels.

7.1.3 Product analysis, when performed, shall be made from finished material representing each lot. To meet the specification, the chemical composition thus determined shall conform to the requirements specified in Table 1 or Table 2 as applicable.

7.1.4 Heats of steel to which bismuth, selenium, tellurium, or lead has been intentionally added shall not be permitted.

7.1.5 For Type 1 bolts made from plain carbon steel or alloy steel, heats of steel which boron has been intentionally added shall not be permitted.

TABLE 1 Chemical Requirements for Type 1 Tension Control Bolts

Carbon Steel		
Element	Heat Analysis	Product Analysis
Carbon	0.30 to 0.52	0.28 to 0.55
Manganese, min	0.60	0.57
Phosphorus, max	0.040	0.048
Sulfur, max	0.050	0.058
Silicon	0.15 to 0.30	0.13 to 0.32
Boron	See 7.1.5 and 7.1.6	
Carbon Boron Steel		
Element	Heat Analysis	Product Analysis
Carbon	0.30 to 0.52	0.28 to 0.55
Manganese, min	0.60	0.57
Phosphorus, max	0.040	0.048
Sulfur, max	0.050	0.058
Silicon	0.10 to 0.30	0.08 to 0.32
Boron	0.0005 to 0.003	0.0005 to 0.003
Alloy Steel		
Element	Heat Analysis	Product Analysis
Carbon	0.30 to 0.52	0.28 to 0.55
Manganese	0.60	0.57
Phosphorus, max	0.035	0.040
Sulfur, max	0.040	0.045
Silicon	0.15 to 0.35	0.13 to 0.37
Boron	See 7.1.5 and 7.1.6	
Alloying Elements	A	A

^A Steel, as defined by the American Iron and Steel Institute, shall be considered to be alloy when the maximum of the range given for the content of alloying elements exceeds one or more of the following limits: manganese, 1.65 %, silicon, 0.60 %, copper, 0.60 %; or in which a definite range or a definite minimum quantity of any of the following elements is specified or required within the limits of the recognized field of constructional alloy steels: aluminum, chromium up to 3.99 %, cobalt, columbium, molybdenum, nickel, titanium, tungsten, vanadium, zirconium, or any other alloying elements added to obtain a desired alloying effect.

7.1.6 Compliance with 7.1.4 and 7.1.5 shall be based on certification that heats of steel having any of the listed elements intentionally added were not used to produce the bolts.

7.1.7 Chemical analysis shall be performed in accordance with Test Methods, Practices, and Definitions A 751.

7.2 *Nuts and Washers*— Chemical requirements for nuts and washers shall be in accordance with the applicable specification specified in 6.6.3.

8. Mechanical Property Requirements for Tension Control Bolts

8.1 *Hardness*: The bolts shall conform to the hardness specified in Table 3.

8.2 *Tensile Properties*:

8.2.1 Bolts having a length of three times the diameter or longer (see 8.2.3) shall be tested full size and shall conform to the tensile strength and proof load or alternative proof load specified in Table 4.

8.2.2 Bolts having a length less than three times the diameter are not subject to tensile tests, except as permitted in 8.2.3.

8.2.3 Bolts having a length of two times the diameter or longer shall be permitted to be tested full size for tensile properties whenever suitable test equipment is available. In such cases reference to “three times the diameter” in Table 3, 8.2.1, and 8.2.2 shall be considered to be “two times the diameter”.

8.2.4 For bolts on which hardness and tension tests are performed, acceptance based on tensile requirements shall take precedence in the event of controversy over low hardness tests.

8.3 *Nuts and Washers*— Mechanical properties for nuts and washers shall be in accordance with the applicable specification in 6.6.3.

9. Assembly Lot Tension Test

9.1 *Purpose*—The assembly lot tension test shall be performed on fastener assemblies to determine the ability of the assembly to provide the required minimum tension.

9.2 *Requirement*— Full size completed assemblies tested in accordance with 14.4 shall develop a bolt tension when the spline end is separated from the bolt conforming to the requirements in Table 5, Column 1.

10. Dimensions

10.1 *Tension Control Bolts*:

10.1.1 Tension control bolts shall be furnished with either round (button or dome), heavy hex structural or alternate design heads; as specified by the purchaser.

10.1.2 The tension control bolts shall have a body conforming to the dimensions for heavy hex structural bolts specified in ANSI B18.2.1 and a spline end conforming to the dimensions in Fig. 1.

10.1.3 Head designs as specified in 10.1.1 shall have a bearing surface area and head height equal to or larger than required for heavy hex structural bolts in ANSI B18.2.1.

10.1.4 Round heads shall conform to the dimensions in Fig. 1.

10.1.5 The thread length shall be as specified in ANSI B18.2.1 for heavy hex structural bolts.

10.2 *Nuts and Washers*— The dimensions for nuts and washers shall be in accordance with the applicable specification specified in 6.6.3.

10.3 *Threads*:

10.3.1 Threads on tension control bolts shall be the Unified Coarse Thread Series as specified in ASME B1.1, and shall have Class 2A tolerances.

10.3.2 Unless otherwise specified, zinc coated tension control bolts to be used with nuts which have been tapped oversize in accordance with Specification A 563, shall have Class 2A threads before mechanically deposited zinc coating.

10.3.3 The gaging limit for bolts shall be verified during manufacture. In case of purchaser/supplier controversy over thread compliance, System 21 of ASME B18.18.3M shall be used for referee purposes.

11. Workmanship, Finish, and Appearance

11.1 Surface discontinuity limits for tension control bolts, inspection, and evaluation of the surface discontinuities, quench cracks, forging cracks, head bursts, shear bursts, seams, folds, thread laps, voids, tool marks, nicks, and gouges shall be in accordance with Specification F 788/F 788M (see Note 3).

NOTE 3—Specifications F 788/F 788M and F 1470 do not guarantee 100 % freedom from head bursts. Sampling is designed to provide a 95 % confidence level of freedom from head bursts in any test lot. Head bursts, within the limits in Specification F 788/F 788M, are unsightly but do not affect mechanical properties or functional requirements of the bolt.

TABLE 2 Chemical Requirements for Type 3 Tension Control Bolts^A

	Composition, %					
	A	B	C	D	E	F
Carbon:						
Heat Analysis	0.33 to 0.40	0.38 to 0.48	0.15 to 0.25	0.15 to 0.25	0.20 to 0.25	0.20 to 0.25
Product Analysis	0.31 to 0.42	0.36 to 0.50	0.14 to 0.26	0.14 to 0.26	0.18 to 0.27	0.19 to 0.26
Manganese:						
Heat Analysis	0.90 to 1.20	0.70 to 0.90	0.80 to 1.35	0.40 to 1.20	0.60 to 1.00	0.90 to 1.20
Product Analysis	0.86 to 1.24	0.67 to 0.93	0.76 to 1.39	0.36 to 1.24	0.56 to 1.04	0.86 to 1.24
Phosphorus:						
Heat Analysis	0.040 max	0.06 to 0.12	0.035 max	0.040 max	0.040 max	0.040 max
Product Analysis	0.045 max	0.06 to 0.125	0.040 max	0.055 max	0.045 max	0.045 max
Sulfur:						
Heat Analysis	0.050 max	0.050 max	0.040 max	0.050 max	0.040 max	0.040 max
Product Analysis	0.055 max	0.055 max	0.045 max	0.050 max	0.045 max	0.045 max
Silicon:						
Heat Analysis	0.15 to 0.35	0.30 to 0.50	0.15 to 0.35	0.25 to 0.50	0.15 to 0.35	0.15 to 0.35
Product Analysis	0.13 to 0.37	0.25 to 0.55	0.13 to 0.37	0.20 to 0.55	0.13 to 0.37	0.13 to 0.37
Nickel:						
Heat Analysis	0.25 to 0.45	0.50 to 0.80	0.25 to 0.50	0.50 to 0.80	0.30 to 0.60	0.20 to 0.40
Product Analysis	0.22 to 0.48	0.47 to 0.83	0.22 to 0.53	0.47 to 0.83	0.27 to 0.63	0.17 to 0.43
Copper:						
Heat Analysis	0.25 to 0.45	0.20 to 0.40	0.20 to 0.50	0.30 to 0.50	0.30 to 0.60	0.20 to 0.40
Product Analysis	0.22 to 0.48	0.17 to 0.43	0.17 to 0.53	0.27 to 0.53	0.27 to 0.63	0.17 to 0.43
Chromium						
Heat Analysis	0.45 to 0.65	0.50 to 0.75	0.30 to 0.50	0.50 to 1.00	0.60 to 0.90	0.45 to 0.65
Product Analysis	0.42 to 0.68	0.47 to 0.83	0.27 to 0.53	0.45 to 1.05	0.55 to 0.95	0.42 to 0.68
Vanadium:						
Heat Analysis	<i>B</i>	<i>B</i>	0.020 min	<i>B</i>	<i>B</i>	<i>B</i>
Product Analysis	<i>B</i>	<i>B</i>	0.010 min	<i>B</i>	<i>B</i>	<i>B</i>
Molybdenum:						
Heat Analysis	<i>B</i>	0.06 max	<i>B</i>	0.10 max	<i>B</i>	<i>B</i>
Product Analysis	<i>B</i>	0.07 max	<i>B</i>	0.11 max	<i>B</i>	<i>B</i>
Titanium:						
Heat Analysis	<i>B</i>	<i>B</i>	<i>B</i>	0.05 max	<i>B</i>	<i>B</i>
Product Analysis	<i>B</i>	<i>B</i>	<i>B</i>	<i>B</i>	<i>B</i>	<i>B</i>

^A Designations A, B, C, D, E, and F are classes of material used for Type 3 tension control bolts. Selection of a class shall be at the option of the bolt manufacturer.

^B These elements are not specified or required. They shall be present only as residuals.

TABLE 3 Hardness Requirements for Tension Control Bolts

Bolt Size in.	Bolt Length, in.	Brinell		Rockwell C	
		Min.	Max.	Min.	Max.
½ to 1 in., incl	Less than 3D ^A	253	319	25	34
	3D and over	...	319	...	34
1½ in.	Less than 3D ^A	223	286	19	30
	3D and over	...	286	...	30

^A Bolts having a length less than three times the diameter, see 8.2.3.
D = Nominal diameter or thread size.

11.2 Surface discontinuity limits for the nut component shall be in accordance with the applicable specification specified in 6.6.3.

12. Visual Inspection for Head Bursts

12.1 *Requirements*— Each bolt component lot shall be visually inspected for head bursts in accordance with the sample size and acceptance values specified in 13.5.6 and shall conform to the requirements in 12.3. Samples shall be taken at random.

12.2 *Burst Definition*— A burst is an open break in the metal (material). Bursts can occur on the periphery of the round head or on the flats or corners of hex heads.

12.3 Defective Criteria:

12.3.1 *Round Heads*— Head bursts shall be evaluated in accordance with the provisions stated in Specification F 788/F 788M for products with circular heads.

12.3.2 *Hex Heads*—Any bolt that contains a burst in the flat of the head that extends into the top crown surface of the head (chamfer circle) or the under-head bearing surface shall be a defective bolt. Head bursts shall be evaluated in accordance with the provisions stated in Specification F 788/F 788M for hex head product.

12.3.3 *Alternate Design Heads*—Any tension control bolt having bursts as specified in 12.3.1 through 12.3.2, as applicable to the head configuration shall be rejected.

13. Testing

13.1 Testing Responsibility:

TABLE 4 Tensile Requirements for Full Size Tension Control Bolts

Bolt Size, Threads per in. and Series Designation	Stress Area ^A in. ²	Tensile Strength ^B lbs, min, lbf	Proof Load Length Measurement Method, lbs	Alternative Proof Load ^B Yield Strength Method min. lbs
Column 1	Column 2	Column 3	Column 4	Column 5
½ in. — 13 UNC	0.142	17 050	12 050	13 050
⅝ in. — 11 UNC	0.226	27 100	19 200	20 800
¾ in. — 10 UNC	0.334	40 100	28 400	30 700
⅞ in. — 9 UNC	0.462	55 450	39 250	42 500
1 in. — 8 UNC	0.606	72 700	51 500	55 750
1⅛ in. — 7 UNC	0.763	80 100	56 450	61 800

^A The stress area is calculated as follows:

$$A_s = 0.7854 [D - (0.9743/n)]^2$$

where:

A_s = stress area, in.²

D = nominal bolt size, and

n = threads per inch.

^B Loads tabulated are based on the following:

Bolt Size, in.	Column 3	Column 4	Column 5
½ to 1, incl.	120 000 psi	85 000 psi	92 000 psi
1⅛	105 000 psi	74 000 psi	81 000 psi

TABLE 5 Assembly Lot Tension Test Requirements

Bolt Size, in. Threads per in. and Series Designation	Manufacturers Acceptance Test Tension, lbs, min ^A		Tension 1 000 of lbs (kips), min (For Information Only) ^B
	Column 1	Column 2	
½ – 13 UNC	13 000	12	
⅝ – 11 UNC	20 000	19	
¾ – 10 UNC	29 000	28	
⅞ – 9 UNC	41 000	39	
1 – 8 UNC	54 000	51	
1⅛ – 7 UNC	59 000	56	

^A The manufacturers acceptance test tension values are 5 % higher than the tension in Column 2 and are rounded to the nearest 1000 lbs.

^B The values in Column 2 are excerpts from the Research Council Specification for Structural Joints Using ASTM A 325 and A 490 Bolts. They are equal to 70 % of the specified minimum tensile strength for tests of full size A 325 bolts with UNC threads tested in axial tension and are rounded to the nearest 1000 pounds (kips).

13.1.1 Each component lot and assembly lot shall be tested by the manufacturer prior to shipment in accordance with the lot identification control quality assurance plan in 13.2 through 13.5.

13.1.2 When components or assemblies are furnished by a source other than the manufacturer, the responsible party as defined in Section 18 shall be responsible for assuring all tests have been performed and the components and assemblies comply with the requirements of this specification.

13.2 *Purpose of Lot Inspection*—The purpose of a lot inspection program is to ensure that each lot conforms to the requirements of this specification. For such a plan to be fully effective it is essential that secondary processors, distributors, and purchasers maintain the identification and integrity of each lot until the assemblies are installed.

13.3 *Lot Control*— All components shall be manufactured, processed, and tested in accordance with a lot control plan that

provides lot purity and lot identification. The manufacturer, secondary processors, and distributors shall identify and maintain the integrity of each lot of components and finished assemblies from raw material selection through all processing operations and treatments to final packing and shipment. Each component lot shall be assigned its own component lot number and each assembly lot its own assembly lot number.

13.4 *Lot Definition*— Component lots and assembly lots shall be defined as specified in Section 3.

13.5 Number of Tests:

13.5.1 Tensile strength, proof load, and hardness sampling shall be in accordance with Guide F 1470.

13.5.2 Chemical composition sampling shall be one test per heat using either the heat or product analysis method.

13.5.3 Assembly lot tension test sample size shall be in accordance with Guide F 1470, Sample Level C, Table 3, as a minimum.

13.5.4 Coating Thickness sampling shall be in accordance with Guide F 1470.

13.5.5 Dimensional and thread fit sampling shall be in accordance with the manufacturers standard quality control practices. In the event of dispute, acceptance shall be based on the requirements for Final Inspection-Non Destructive shown in ANSI B18.18.3M.

13.5.6 Surface discontinuity sampling, including Head Bursts, shall be in accordance with Specification F 788/F 788M.

13.5.7 Sampling for the nut and washer components shall be in accordance with the applicable nut and washer specification referenced in 6.6.3.

13.5.8 When tested in accordance with the required sampling plan, a component lot shall be rejected if any of the test specimens fail to meet the applicable requirements.

14. Test Methods

14.1 Perform chemical analyses in accordance with Test Methods, Practices, and Terminology A 751.

14.2 *Tensile and Hardness*—Conduct tensile and hardness tests in accordance with Test Methods F 606 using the wedge tension testing of full size product method to determine full size tensile strength.

14.3 *Proof Load*—Conduct proof load tests in accordance with Test Methods F 606 Method 1, Length Measurement, or Method 2, Yield Strength: at the option of the manufacturer.

14.4 *Assembly Installation Tension Test*:

14.4.1 *Test Conditions*— Conduct tests at an ambient temperature between 50° and 90° F (10 and 32°C).

14.4.2 *Test Device*:

14.4.2.1 The tension measuring device shall be capable of measuring the assembly tension after torquing.

14.4.2.2 The tension measuring device shall be calibrated in 1000 lb (454 kg) increments.

14.4.2.3 Calibrate the tension measuring device (and any other equipment) based on the frequency of use and the equipment manufacturers recommendation, but not less than one time per year.

14.4.3 *Installation and Tension Test*:

14.4.3.1 Install the tension control bolt, nut, washer, and appropriate spacer washer(s) in the tension measuring device. The device shall not restrain the head from turning.

14.4.3.2 Install the washer(s) under the nut such that three to five threads of the bolt are located between the bearing face of the nut and the underside of the bolt head using the washer furnished with the assembly in contact with the nut.

14.4.3.3 Initially tighten the assembly using a hand wrench by turning the nut to produce the setting tension specified below.

Bolt Diameter, in.	Setting Tension	Tension, 1000 lb
1/2		1 to 3
5/8		2 to 4
3/4		3 to 5
7/8		4 to 6
1		5 to 7
1 1/8		6 to 8

14.4.3.4 Complete tightening the assembly nut using a spline drive installation tool capable of engaging the nut and spline end simultaneously during this process. Tighten continuously until the spline shears from the bolt.

14.4.3.5 The bolt component, regardless of head style, shall not be restrained during the assembly tightening.

14.4.3.6 In order to pass, shearing of the spline end shall occur in the shear groove. Failure in the threaded region shall be considered nonconforming.

14.4.3.7 Record the tension after shearing of the spline end as the assembly installation tension.

15. Inspection

15.1 If the inspection described in 15.2 is required by the purchaser, it shall be specified in the inquiry and contract or order.

15.2 The purchaser’s quality assurance representative shall have free entry to all parts of the manufacturer’s works or suppliers place of business, that concern the manufacture or

supply of the assemblies. The manufacturer or supplier shall afford the purchaser’s quality assurance representative all reasonable facilities to satisfy him that the assemblies are being furnished in accordance with this specification. All tests and inspections required by the specification that are requested by the purchaser’s representative shall be made before shipment, and shall be conducted so as not to interfere unnecessarily with the operation of the manufacturers or suppliers operations.

16. Rejection and Rehearing

16.1 Disposition of nonconforming sets shall be in accordance with Guide F 1470 the section titled “Disposition of Nonconforming Lots.”

17. Certification

17.1 The manufacturer or supplier, whichever is the responsible party as defined in Section 18, shall furnish the purchaser a test report for each lot that includes the following:

17.1.1 Heat analysis and heat number of each component (bolt, nut and washer), and a statement certifying that heats having the elements listed in 7.1.4 and 7.1.5 intentionally added were not used to produce the tension control bolts,

17.1.2 Results of hardness, tensile and proof load tests of each component (bolt, nut and washer),

17.1.3 *Results of Assembly Lot Installation Tension Tests*—At the manufacturers option the mean and standard deviations may be reported,

17.1.4 Results of zinc coating thickness measurements,

17.1.5 Results of visual inspection for bursts,

17.1.6 Statement of compliance with dimensional and thread fit requirements,

17.1.7 Assembly lot number, individual component lot numbers for bolt-nut-washer, and purchase order number,

17.1.8 ASTM specification number, type, and issue date,

17.1.9 Complete mailing address of responsible party, and

17.1.10 Title and signature of the individual assigned certification responsibility by the company officers.

17.2 Failure to include all the required information on the test report shall be cause for rejection.

18. Responsibility

18.1 The party responsible for the assemblies shall be the organization that supplies the assemblies to the purchaser and certifies that the assemblies have been manufactured, sampled, tested and inspected in accordance with this specification and meets all of its requirements.

19. Product Marking

19.1 *Manufacturers Identification*—All components of each assembly shall be marked by the manufacturer with a unique identifier to identify the manufacturer.

19.2 *Grade Identification*:

19.2.1 Type 1 tension control bolts shall be marked “A325TC,” and at the manufacturer’s option, with three radial lines 120° apart.

19.2.2 Type 3 tension control bolts shall be marked “A325TC” with all characters underlined. Manufacturers shall be permitted to use additional marks indicating the bolt is a weathering type.

19.3 *Marking Location and Methods*—All markings shall be located on the top of the bolt head and shall be raised or depressed at the manufacturers option. The nut and washer marking shall be depressed.

19.4 *Acceptance Criteria*—Tension control bolts which are not marked in accordance with these provisions shall be considered nonconforming and subject to rejection.

20. Packaging and Package Marking

20.1 *Packaging*:

20.1.1 Unless otherwise specified, packaging shall be in accordance with Practice D 3951.

20.1.2 All product shall be assembled.

20.1.3 When special packaging requirements are required they shall be defined at the time of the inquiry and order.

20.2 *Package Marking*:

20.2.1 Each shipping unit shall include or be plainly marked with the following information:

20.2.1.1 ASTM designation and type,

20.2.1.2 Size, nominal diameter and length,

20.2.1.3 Name of the manufacturer; and the supplier, if furnished by an entity other than the manufacturer,

20.2.1.4 Number of assemblies,

20.2.1.5 Assembly lot number (s),

20.2.1.6 Purchase order number (s), and

20.2.1.7 Country of origin.

21. Keywords

21.1 alternate design fasteners; bolts; carbon steel; fasteners; spline end; structural; tension control bolt; tension control bolt assembly; twist-off bolt; weathering steel

SUMMARY OF CHANGES

Committee F16 has identified the location of selected changes to this standard since the last issue, F 1852–02, that impact the use of this standard. (Approved Jan. 1, 2004.)

(1) Deleted old Section 1.5.

(2) Added new Section 1.5 that references Terminology F 1789 for definitions of terms.

(3) Revised Section 11.1 to include a note recognizing that Specification F 788/F 788M nor Specification F 1470 guarantee 100 % freedom from head burst.

Committee F16 has identified the location of selected changes to this standard since the last issue, F 1852–00, that impact the use of this standard. (Approved Dec. 10, 2002.)

(1) In Table 4, corrected the stress area for the $\frac{5}{8}$ – 11 UNC bolt size from 0.266 to 0.226.

ASTM International takes no position respecting the validity of any patent rights asserted in connection with any item mentioned in this standard. Users of this standard are expressly advised that determination of the validity of any such patent rights, and the risk of infringement of such rights, are entirely their own responsibility.

This standard is subject to revision at any time by the responsible technical committee and must be reviewed every five years and if not revised, either reapproved or withdrawn. Your comments are invited either for revision of this standard or for additional standards and should be addressed to ASTM International Headquarters. Your comments will receive careful consideration at a meeting of the responsible technical committee, which you may attend. If you feel that your comments have not received a fair hearing you should make your views known to the ASTM Committee on Standards, at the address shown below.

This standard is copyrighted by ASTM International, 100 Barr Harbor Drive, PO Box C700, West Conshohocken, PA 19428-2959, United States. Individual reprints (single or multiple copies) of this standard may be obtained by contacting ASTM at the above address or at 610-832-9585 (phone), 610-832-9555 (fax), or service@astm.org (e-mail); or through the ASTM website (www.astm.org).