



Standard Practice for Verification of Algorithm and Equipment for Electrochemical Impedance Measurements¹

This standard is issued under the fixed designation G 106; the number immediately following the designation indicates the year of original adoption or, in the case of revision, the year of last revision. A number in parentheses indicates the year of last reapproval. A superscript epsilon (ε) indicates an editorial change since the last revision or reapproval.

1. Scope

1.1 This practice describes an experimental procedure which can be used to check one's instrumentation and technique for collecting and presenting electrochemical impedance data. If followed, this practice provides a standard material, electrolyte, and procedure for collecting electrochemical impedance data at the open circuit or corrosion potential that should reproduce data determined by others at different times and in different laboratories. This practice may not be appropriate for collecting impedance information for all materials or in all environments.

1.2 *This standard does not purport to address all of the safety concerns, if any, associated with its use. It is the responsibility of the user of this standard to establish appropriate safety and health practices and determine the applicability of regulatory limitations prior to use.*

2. Referenced Documents

2.1 ASTM Standards:

- D 1193 Specification for Reagent Water²
- G 3 Practice for Conventions Applicable to Electrochemical Measurements in Corrosion Testing³
- G 5 Reference Test Method for Making Potentiostatic and Potentiodynamic Anodic Polarization Measurements³
- G 15 Terminology Relating to Corrosion and Corrosion Testing³
- G 59 Practice for Conducting Potentiodynamic Polarization Resistance Measurements³

3. Terminology

3.1 *Definitions*—For definitions of corrosion related terms, see Terminology G 15.

3.2 Symbols:

- C = capacitance (farad-cm⁻²)
- E' = real component of voltage (volts)

¹ This practice is under the jurisdiction of ASTM Committee G-1 on Corrosion of Metals and is the direct responsibility of Subcommittee G01.11 on Electrochemical Measurements in Corrosion Testing.

Current edition approved Sept. 29, 1989. Published November 1989. Originally published as G 106-89. Last previous edition G 106 - 89 (1994)^ε.

² *Annual Book of ASTM Standards*, Vol 11.01.

³ *Annual Book of ASTM Standards*, Vol 03.02.

- E'' = imaginary component of voltage (volts)
- E = complex voltage (volts)
- f = frequency (s⁻¹)
- I' = real component of current (amp-cm⁻²)
- I'' = imaginary component of current (amp-cm⁻²)
- I = complex current (amp-cm⁻²)
- j = $\sqrt{-1}$
- L = inductance (henry – cm²)
- R_s = solution resistance (ohm-cm²)
- R_p = polarization resistance (ohm-cm²)
- R_t = charge transfer resistance (ohm-cm²)
- Z' = real component of impedance (ohm-cm²)
- Z'' = imaginary component of impedance (ohm-cm²)
- Z = complex impedance (ohm-cm²)
- α = phenomenological coefficients caused by depression of the Nyquist plot below the real axis, α is the exponent and τ is the time constant(s).
- θ = phase angle (deg)
- ω = frequency (radians-s⁻¹)

Subscripts:

- x = in-phase component
- y = out-of-phase component

4. Summary of Practice

4.1 Reference impedance plots in both Nyquist and Bode format are included. These reference plots are derived from the results from nine different laboratories that used a standard dummy cell and followed the standard procedure using a specific ferritic type alloy UNS-S43000⁴ in 0.005 M H₂SO₄ and 0.495 M Na₂SO₄. The plots for the reference material are presented as an envelope that surrounds all of the data with and without inclusion of the uncompensated resistance. Plots for one data set from one laboratory are presented as well. Since the results from the dummy cell are independent of laboratory, only one set of results is presented.

4.2 A discussion of the electrochemical impedance technique, the physics that underlies it, and some methods of interpreting the data are given in the Appendix X1-Appendix X6. These sections are included to aid the individual in understanding the electrochemical impedance technique and

⁴ These standard samples are available from ASTM Headquarters. Generally, one sample can be repolished and reused for many runs. This procedure is suggested to conserve the available material. Order PCN 12-700050-00.

some of its capabilities. The information is not intended to be all inclusive.

5. Significance and Use

5.1 The availability of a standard procedure, standard material, and standard plots should allow the investigator to check his laboratory technique. This practice should lead to electrochemical impedance curves in the literature which can be compared easily and with confidence.

5.2 Samples of a standard ferritic type 430 stainless steel (UNS 430000) used to obtain the reference plots are available for those who wish to check their equipment. Suitable resistors and capacitors can be obtained from electronics supply houses.

5.3 This test method may not be appropriate for electrochemical impedance measurements of all materials or in all environments.

6. Apparatus

6.1 *Dummy Cell*—The dummy cell used to check the equipment and method for generating electrochemical impedance data is composed of a 10 Ω precision resistor placed in series with a circuit element composed of a 100 Ω precision resistor in parallel with a 100 μF capacitor. The resistors should have a stated precision of ±0.1 %. The capacitor can have a precision of ±20 %. The cell can be constructed from readily available circuit elements by following the circuit diagram shown in Fig. 1.

6.2 *Test Cell*—The test cell should be constructed to allow the following items to be inserted into the solution chamber: the test electrode, two counter electrodes or a symmetrically arranged counter electrode around the working electrode, a Luggin-Haber capillary with salt bridge connection to the reference electrode, an inlet and an outlet for an inert gas, and a thermometer or thermocouple holder. The test cell must be constructed of materials that will not corrode, deteriorate, or otherwise contaminate the solution.

6.2.1 One type of suitable cell is described in Reference Test Method G 5. Cells are not limited to that design. For example, a 1-L round-bottom flask can be modified for the addition of various necks to permit the introduction of electrodes, gas inlet and outlet tubes, and the thermometer holder. A Luggin-Haber capillary probe could be used to separate the bulk solution from the saturated calomel electrode. The capillary tip can be easily adjusted to bring it into close proximity to the working electrode. The minimum distance should be no less than two capillary diameters from the working electrode.

6.3 *Electrode Holder*—The auxillary and working electrodes can be mounted in the manner shown in Reference Test Method G 5. Precautions described in Reference Test Method G 5 about assembly should be followed.

6.4 *Potentiostat*—The potentiostat must be of the kind that allows for the application of a potential sweep as described in Reference Test Method G 5 and Reference Practice G 59. The potentiostat must have outputs in the form of voltage versus ground for both potential and current. The potentiostat must have sufficient bandwidth for minimal phase shift up to at least 1000 Hz and preferably to 10 000 Hz. The potentiostat must be capable of accepting an external excitation signal. Many commercial potentiostats meet the specification requirements for these types of measurements.

6.5 *Collection and Analysis of Current-Voltage Response*—The potential and current measuring circuits must have the characteristics described in Reference Test Method G 5 along with sufficient band-width as described above. The impedance can be calculated in several ways, for example, by means of a transfer function analyzer, Lissajous figures on an oscilloscope, or transient analysis of a white noise input using a Fast Fourier Transform algorithm. Other methods of analysis exist.

6.6 Electrodes:

6.6.1 Working electrode preparation should follow Reference Test Method G 5, which involves drilling and tapping the specimen and mounting it on the electrode holder.

6.6.2 Auxillary electrode preparation should follow Reference Test Method G 5. The auxillary electrode arrangement should be symmetrical around the working electrode.

6.6.3 Reference electrode type and usage should follow Reference Test Method G 5. The reference electrode is to be a saturated calomel electrode.

7. Experimental Procedure

7.1 *Test of Algorithm and Electronic Equipment (Dummy Cell)*:

7.1.1 Measure the impedance of a dummy cell consisting of a 10 Ω resistor in series with a parallel combination of a 100 Ω resistor and a 100 μF capacitor. The circuit diagram is shown in Fig. 1.

7.1.2 Typical connections from the potentiostat are shown in Fig. 1. Connect the auxillary electrode and reference electrode leads to the series resistor side of the circuit. Connect the working electrode lead to the opposite side of the circuit beyond the resistor-capacitor parallel combination.

7.1.3 Set the potential at 0.0V. Collect the electrochemical

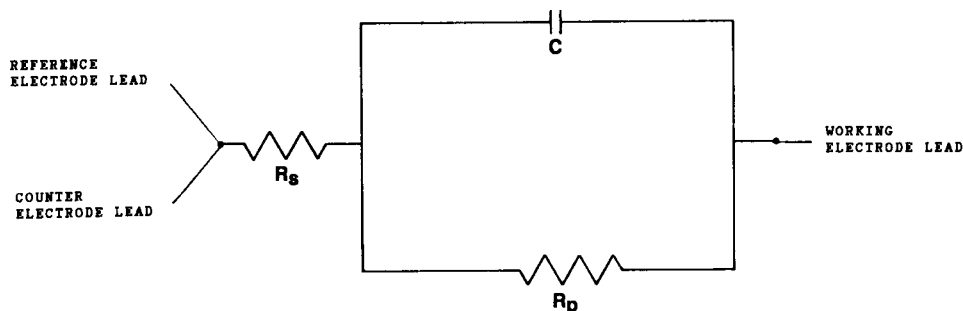

FIG. 1 Circuit Diagram for Dummy Cell Showing Positions for Hook-Up to Potentiostat

impedance data between 10 000 Hz (10 kHz) and 0.1 Hz (100 mHz) at 8 to 10 steps per frequency decade. The amplitude must be the same as that used to check the electrochemical cell, 10 mv. The resulting frequency response when plotted in Nyquist format (the negative of the imaginary impedance versus the real impedance) must agree with that shown in Figs. 2-4. Testing with the electrochemical cell should not be attempted until that agreement is established. Results using the dummy circuit were found to be independent of laboratory.

7.2 Test of Electrochemical Cell:

7.2.1 Test specimens of the reference material should be prepared following the procedure described in Reference Test Method G 5. This procedure involves polishing the specimen with wet SiC paper with a final wet polish using 600 grit SiC paper prior to the experiment. There should be a maximum delay of 1 h between final polishing and immersion in the test solution.

7.2.2 Prepare a 0.495 M Na₂SO₄ solution containing 0.005 M H₂SO₄ from reagent grade sulfuric acid and sodium sulfate and Type IV reagent water described in Specification D 1193. The test is to be carried out at 30 ± 1°C.

7.2.3 At least 1 h before specimen immersion, start purging the solution with oxygen-free argon, hydrogen, or nitrogen gas at a flow rate of about 100 to 150 cm³/min. Continue the purge throughout the test.

7.2.4 Transfer the specimen to the test cell. Adjust the Luggin-Haber probe tip so that it is no less than two capillary diameters from the sample. However, since this distance will affect the uncompensated solution resistance, the greater the distance, the larger the resistance. Therefore, close placement is important.

7.2.5 Connect the potentiostat leads to the appropriate electrodes, for example, working electrode lead to working electrode, counter electrode lead to counter electrode, and reference electrode lead to reference electrode. Hook-up instructions provided with the potentiostat must be followed.

ASTM EQUIVALENT CIRCUIT

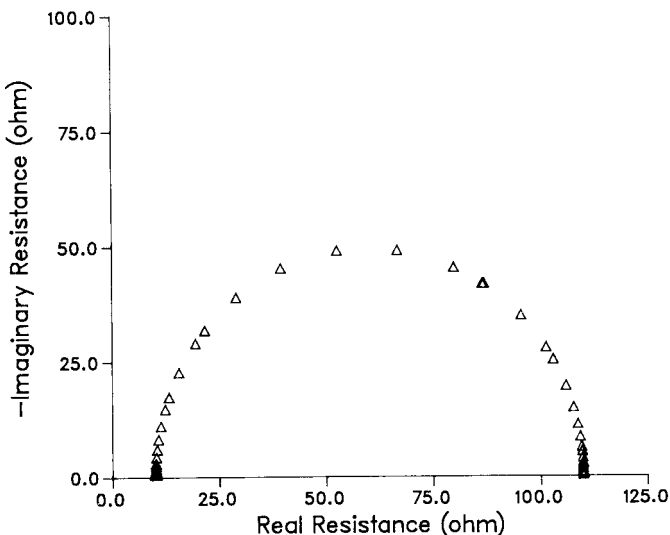

FIG. 2 Nyquist Plot of Electrochemical Impedance Response for Dummy Cell

ASTM EQUIVALENT CIRCUIT

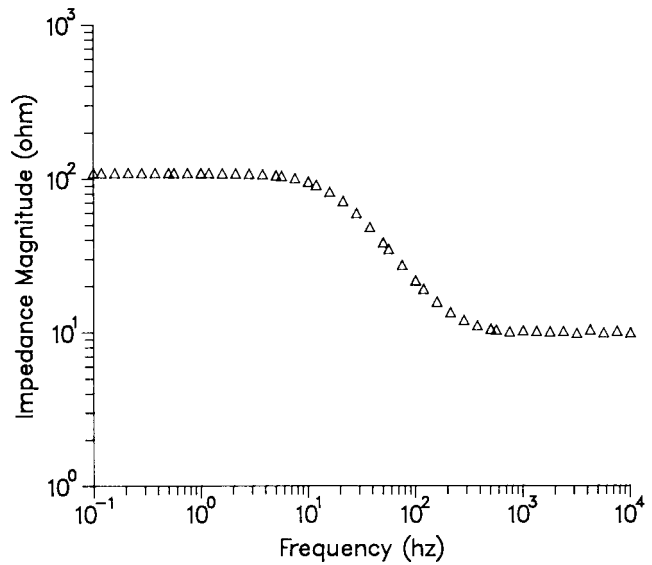

FIG. 3 Bode Plot, Impedance Magnitude Versus Frequency, of Electrochemical Impedance Response for Dummy Cell

ASTM EQUIVALENT CIRCUIT

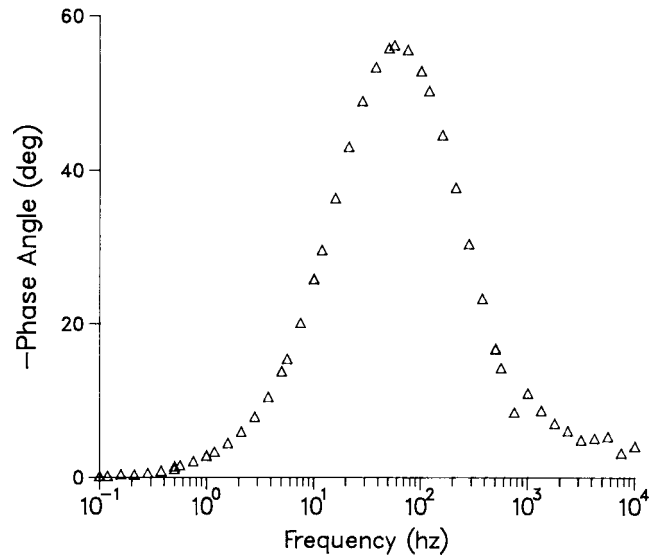

FIG. 4 Bode Plot, Phase Angle Versus Frequency, of Electrochemical Impedance Response for Dummy Cell

7.2.6 Record the open circuit potential, that is, the corrosion potential, for 1 h. The potential should be about -645 mv ± 10 mv relative to the saturated calomel electrode. If the potential is more positive than -600 mv (SCE) then the specimen may have passivated. If so, remove the specimen and repolish with 600 grit wet silicon carbide paper. Then reimmerse the sample and monitor the corrosion potential for 1 h. If the potential again becomes more positive than -600 mv (SCE) check for oxygen contamination of the solution.

7.2.7 Record the frequency response between 10 000 Hz (10 kHz) and 0.1 Hz (100 mHz) at the corrosion potential

recorded after 1 h of exposure using 8 to 10 steps per frequency decade. The amplitude must be the same as that used in 6.1.3, 10 mv.

7.2.8 Plot the frequency response in both Nyquist format (real response versus the negative of the imaginary response) and Bode format (impedance modulus and phase angle versus frequency). Frequency can be reported in units of radians/second or hertz (cycles/s).

7.2.9 There was no attempt to estimate circuit analogues for the electrochemical impedance curves since there is no universally recognized, standard method for making such estimates.

8. Standard Reference Results and Plots

8.1 Dummy Cell:

8.1.1 The results from nine different laboratories were virtually identical and overlaid each other almost perfectly. Typical plots of the raw data are shown in Figs. 2-4. No attempt has been made to estimate the variance and standard deviation of the results from the nine laboratories. The measured values of R_s , R_p , and the frequency at which the phase angle is a maximum must agree with these curves within the specifications of the instrumentation, resistors, and capacitors before testing of the electrochemical cell commences. See 9.1.1.

8.2 Electrochemical Cell:

8.2.1 Standard electrochemical impedance plots in both Nyquist format and Bode format are shown in Figs. 5-7. These are actual results from one laboratory. Figs. 8-10 show plots in both Nyquist and Bode formats which envelop all of the results from the nine laboratories. The solution resistance from each laboratory was not subtracted out prior to making this plot.

8.2.2 The average solution resistance from the nine laboratories in $3.3 \Omega\text{-cm}^2 \pm 1.8 \Omega\text{-cm}^2$ (one standard deviation). The solution resistance of the user's test cell as measured by the high frequency intercept on the Nyquist plot must lie in this range to use agreement with Figs. 8-10 for verification of the electrochemical test cell. If the uncompensated resistance lies outside of this range, it should be subtracted from the results (see 7.2.4). Then, results from the electrochemical test cell can

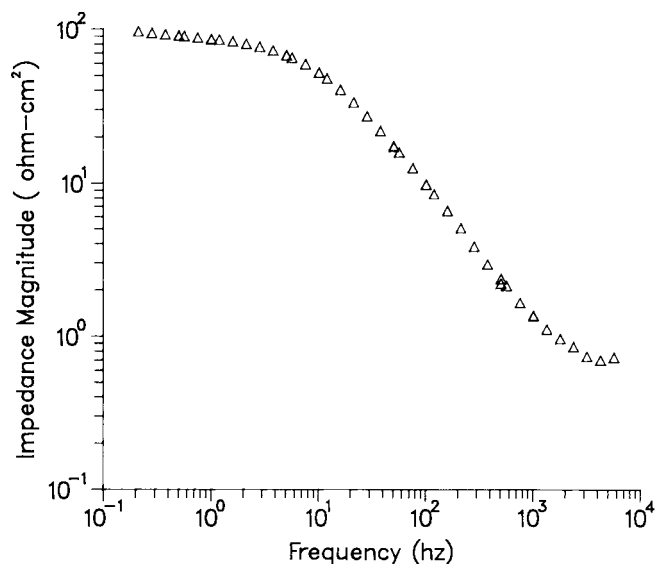

FIG. 6 Bode Plot, Impedance Magnitude Versus Frequency, for UNS-S43000 From One Laboratory

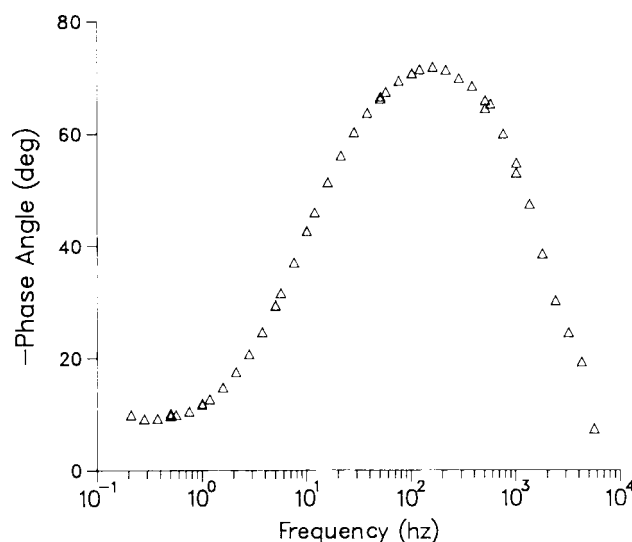

FIG. 7 Bode Plot, Phase Angle Versus Frequency, for UNS-S43000 From One Laboratory

be compared with the results in Figs. 11-13 to verify the test cell. Figs. 11-13 envelop all of the results from the nine laboratories with the uncompensated resistance subtracted out.

9. Precision and Bias

9.1 Dummy Cell:

9.1.1 Reproducibility of the results for the dummy cell is dependent on the precision of the resistors and capacitor used to construct the dummy cell. Precision resistors ($\pm 0.1\%$) should be used to construct the dummy cell. Most capacitors have a precision of $\pm 20\%$. A change in the value of the capacitor will change the frequency at which the maximum phase angle occurs in Fig. 4. In Nyquist format the intercepts with the real axis should agree with the resistor values (R_s and R_p) shown in Fig. 2.

9.2 Electrochemical Cell:

9.2.1 The reported corrosion potential was $-645 \text{ mV} \pm 9$

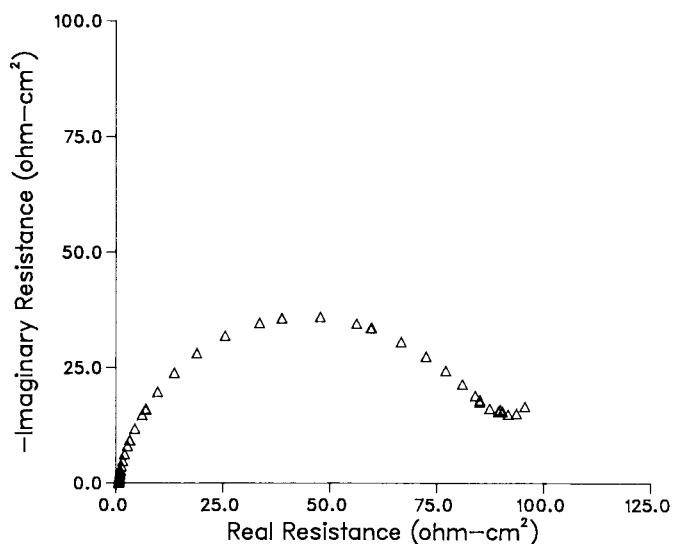

FIG. 5 Nyquist Plot of Typical Frequency Response for UNS-S43000 From One Laboratory

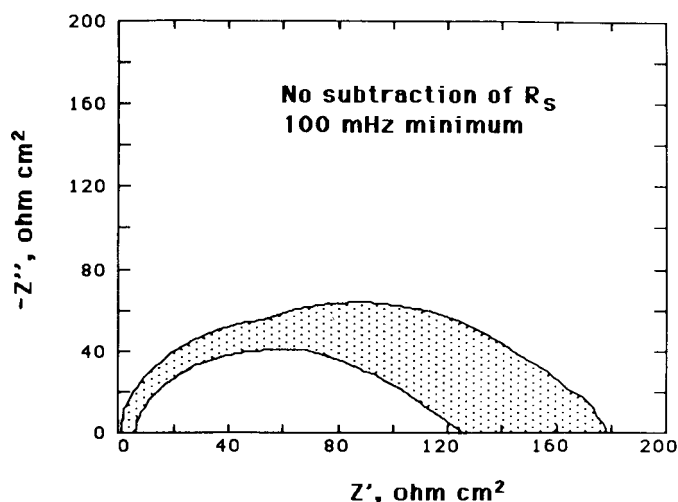

FIG. 8 Envelope of Data From All Laboratories, Nyquist Plot, Solution Resistance Included

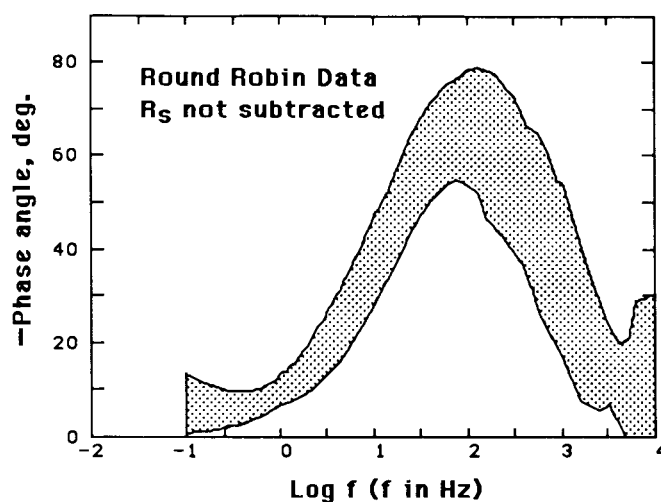

FIG. 10 Envelope Of Data From All Laboratories, Bode Plot (Phase Angle Versus Frequency), Solution Resistance Included

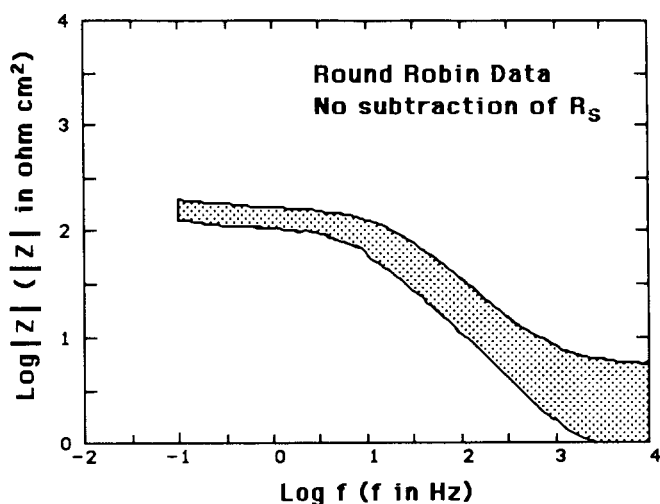

FIG. 9 Envelope of Data From All Laboratories, Bode Plot (Impedance Magnitude Versus Frequency), Solution Resistance Included

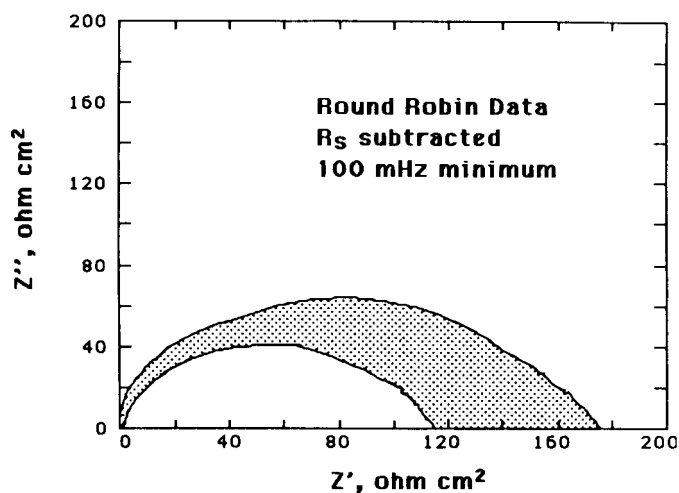

FIG. 11 Envelope Of Data From All Laboratories, Nyquist Plot, Solution Resistance Removed

mV (one standard deviation). The corrosion potential varied between -627 mV and -662 mV with most of the results lying between -640 mV and -650 mV.

9.2.2 The increasing scatter with decreasing frequency seen in the plots is most likely caused by a competing (mass transfer) contribution becoming important at low frequency. This mechanism results in a second time constant arising at frequencies lower than 50 to 100 mHz. The magnitude of this time constant is dependent on the cell geometry and its effect on convection. Thus, reproducibility of the second time constant between laboratories would be expected to be poor. Since this effect will have a greater effect on the frequency response at the lower frequencies in the test, the scatter in the results increases with decreasing frequency.

9.2.3 The increasing scatter in the high frequency portion of Figs. 8-10 is caused by the variation in uncompensated resistance among laboratories. A large contributor to the uncompensated resistance is the solution resistance. This resistance is a function of cell geometry, position of the reference electrode sensing point relative to the working electrode, etc. Further information can be found in Refs (1-2).⁵

10. Keywords

10.1 ac impedance; algorithm verification; Bode; dummy cell; equipment verification; electrochemical impedance; electrochemical impedance spectroscopy; electrochemical measurement; Nyquist; polarization resistance; steel

⁵ The boldface numbers in parentheses refer to the list of references at the end of this standard.

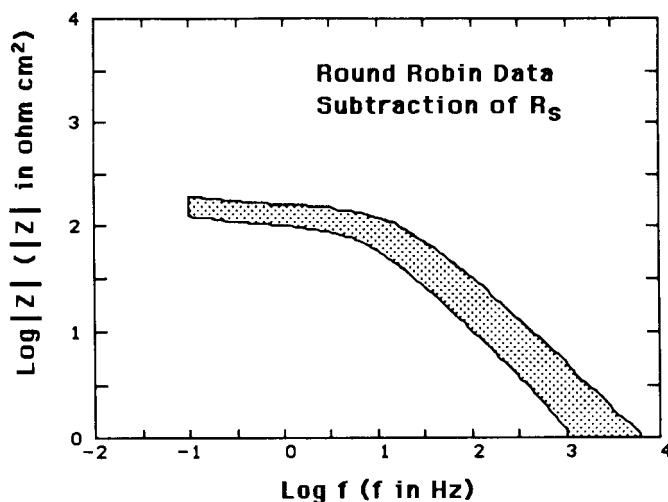

FIG. 12 Envelope Of Data From All Laboratories, Bode Plot (Impedance Magnitude Versus Frequency), Solution Resistance Removed

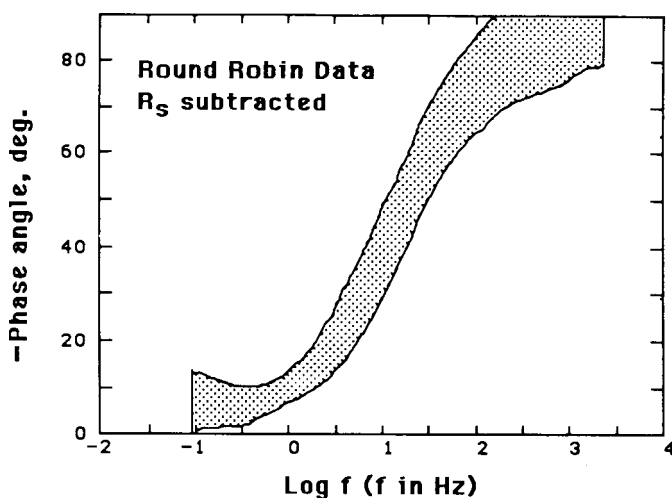

FIG. 13 Envelope Of Data From All Laboratories, Bode Plot (Phase Angle Versus Frequency), Solution Resistance Removed

APPENDIXES

(Nonmandatory Information)

X1. TECHNIQUE BACKGROUND

X1.1 An electrochemical process may often be modeled by linear circuit elements such as resistors, capacitors, and inductors. For example, the corrosion reaction itself can often be modeled by one or more resistors. The ability to model a corrosion process in this manner gives rise to one practical attribute of the electrochemical impedance technique. Simple AC circuit theory in terms of circuit analogues can be used to model the electrochemical corrosion process. Such modeling can facilitate understanding and lead to better prediction of corrosion rates and overall corrosion behavior. A number of reviews exist on the electrochemical impedance technique (3-7)⁵ that illustrate the utility of this type of modeling.

X1.2 Direct current can be viewed as current generated in the limit of zero frequency. Under conditions of direct current, for example zero frequency, Ohm's law can be written as:

$$E = I \times R \quad (X1.1)$$

X1.3 All symbols are defined in 3.2. In this case, the proportionality factor relating current to voltage is composed only of one or more actual resistors. When the frequency is not zero, as would occur from an imposition of a frequency dependent voltage or current, Ohm's law becomes:

$$E = I \times Z \quad (X1.2)$$

X1.4 Under these conditions, the proportionality factor Z is

composed of all elements that can impede or oppose the current. The magnitude of the resistance or opposition to the current created by some of these elements, for example, capacitors and inductors, is dependent on the frequency. The magnitude of the opposition created by the resistor is independent of frequency.

X1.5 The technique can most easily be described in terms of a response to a frequency dependent input signal. When a voltage sine or cosine wave is applied across a circuit composed of a resistor only, the resultant current is also a sine or cosine wave of the same frequency with no phase angle shift but with an amplitude which differs by an amount determined by the proportionality factor. The values of the input voltage and output current are related by equation (X1.1). On the other hand, if the circuit consists of capacitors and inductors, the resulting current not only differs in amplitude but is also shifted in time. It has a phase angle shift. This phenomenon is shown in Fig. X1.1.

X1.6 Use of sines and cosines is cumbersome mathematically. Vector analysis provides a convenient method of describing the analogous circuit in mathematical terms. The relationship between such vector analysis and imaginary or complex numbers provides the basis for electrochemical impedance analysis. A sinusoidal current or voltage can be pictured as a rotating vector as shown in Fig. X1.2. In this figure, the current vector rotates at a constant angular frequency f (hertz) or ω (radians/s = $2\pi f$). In Fig. X1.2, the x component defines the in-phase current. Therefore, it becomes the “real” component of the rotating vector. The y component is shifted out-of-phase by 90° . By convention, it is termed the “imaginary” component of the rotating vector. The mathematical description of the two components is

$$\text{Real Current} = I_x = |I| \cos(\omega t) \quad (\text{X1.3})$$

$$\text{Imaginary Current} = I_y = |I| \sin(\omega t) \quad (\text{X1.4})$$

$$|I|^2 = |I_x|^2 + |I_y|^2 \quad (\text{X1.5})$$

X1.7 The voltage can be pictured as a similar rotating vector with its own amplitude E and the same rotation speed ω . As shown in Fig. X1.3, when the current is in phase with the applied voltage, the two vectors are coincident and rotate together. This response is characteristic of a circuit containing

only a resistor. When the current and voltage are out-of-phase, the two vectors rotate at the same frequency, but they are offset by an angle called the phase angle, θ . This response is characteristic of a circuit which contains capacitors and inductors in addition to resistors.

X1.8 In electrochemical impedance analysis, one “views” one of the vectors from the frame of reference of the other. Thus, the reference point rotates and the time dependence of the signals (ωt) is not viewed. In addition, both the current and voltage vectors are referred to the same reference frame. The voltage vector is “divided” by the current vector to yield the final result in terms of the impedance as shown in Fig. X1.4. The impedance is the proportionality factor between the voltage and the current.

X1.9 The mathematical convention for separating the real (x) and imaginary (y) components is to multiply the magnitude of the imaginary contribution by j and report the real and imaginary values as a complex number. The equations for electrochemical impedance become:

$$E = E_{\text{real}} + E_{\text{imaginary}} = E' + jE'' \quad (\text{X1.6})$$

$$I = I_{\text{real}} + I_{\text{imaginary}} = I' + jI'' \quad (\text{X1.7})$$

$$Z = Z' + jZ'' = \frac{E' + jE''}{I' + jI''} \quad (\text{X1.8})$$

$$\tan \theta = \frac{Z''}{Z'} \quad (\text{X1.9})$$

$$|Z|^2 = (Z')^2 + (Z'')^2 \quad (\text{X1.10})$$

X1.10 Note that by convention, the term Z is reported as $Z' + jZ''$ so that the Nyquist plot of the circuit in Fig. 1 lies in the first quadrant. The goal of the electrochemical impedance technique is to measure the impedance Z (Z' and Z'') as a function of frequency and to derive corrosion rate or mechanism information from the values. Use of simple circuit analogues to model the response is one methodology to achieve this goal. The amplitude of the excitation signal must be small enough so that the response is linearly related to the input, that is, the response is independent of the magnitude of the excitation. If a voltage excitation is used, an amplitude of 10 mv peak-to-peak will often suffice though systems exist in which the excitation may have to be smaller, for example, 2 mv peak-to-peak. If such linearity exists, then the measured response may often be assumed to be modelable by a linear array of resistors, capacitors, and inductors. The three basic circuit elements can be written as shown in Table X1.1. Table X1.1 shows that a resistor has a real contribution only. That is, the response of a resistor would be a point on the real axis, independent of frequency. Both the capacitor and inductor have purely imaginary contributions. These would appear on the imaginary axis only. One method of electrochemical impedance analysis is to model the corrosion process in terms of circuit elements such as those shown in Table X1.1 and from that model to make conclusions about the physics of corrosion process.

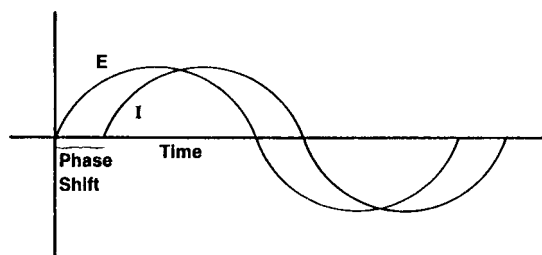

FIG. X1.1 Sinusoidal AC Voltage and Current Signals

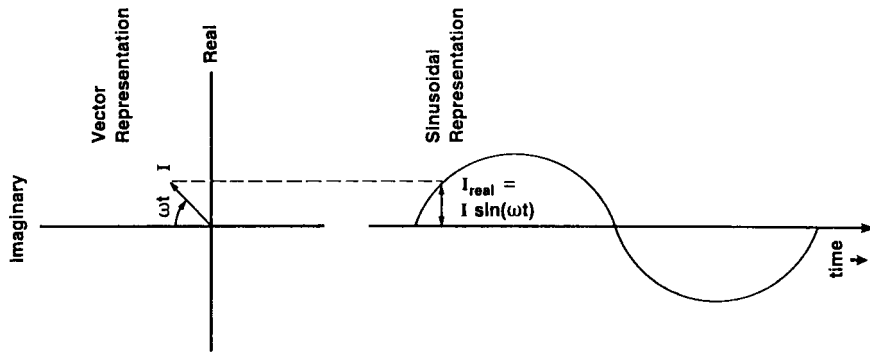

FIG. X1.2 Relationship Between Sinusoidal AC Current and Rotating Vector Representation

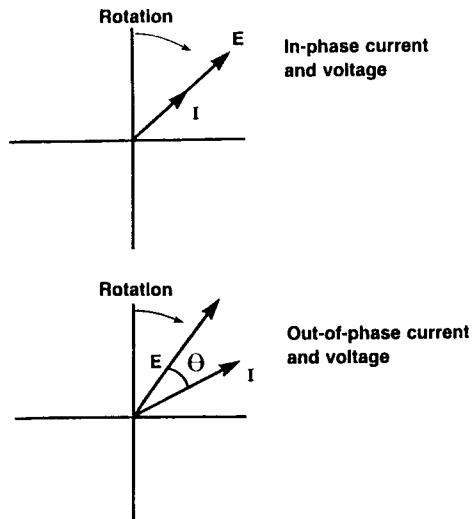

FIG. X1.3 In-Phase and Out-Of-Phase Rotation of Current and Voltage Vectors

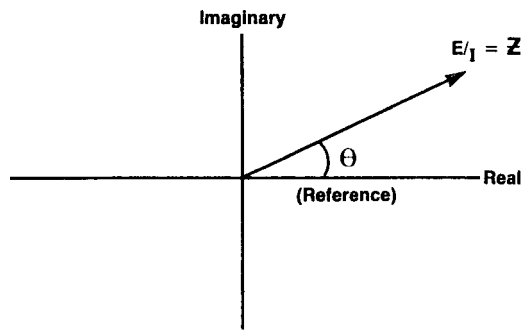

FIG. X1.4 Impedance Vector

TABLE X1.1 Circuit Elements

Element	Equation
Resistor	$Z = R$
Capacitor	$Z = -1/(\omega C) = -2\pi f C$
Inductor	$Z = j\omega L = 2\pi f L$

X2. SIMPLE CORROSION PROCESS

X2.1 The simplest type of corrosion process would be a combination of a corrosion reaction consisting of two simple

electrochemical reactions and a double layer. Corrosion would proceed uniformly on the surface. For example, the corrosion

of carbon steel in 1 M sulfuric acid can be considered to fall into this category (8). (Eq X2.1),

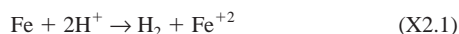

describes the corrosion reaction. This reaction may be represented by a simple resistor. The double layer is created by the voltage change across the interface. On the metal side of the interface, there may be an excess (or deficiency) of electrons. This excess (or deficiency) is balanced on the solution side by oppositely charged ions (9). Some are specifically adsorbed at the surface (inner layer). Others are non-specifically adsorbed and are hydrated. They extend out into the solution in the diffuse layer. The response of this interfacial structure to varying voltage (for example sinusoidal excitation) can be modeled by a capacitor, the double layer capacitance.

X2.2 For this simple process, the model circuit is that shown in Fig. X2.1. The circuit is a resistor R_p in parallel with a capacitor C . The entire parallel circuit is in series with another resistor R_s . The utility of this model for the frequency response lies in the fact that R_s equals the solution resistance not compensated by the potentiostat and R_p equals the polarization resistance as long as the measurement is made at the

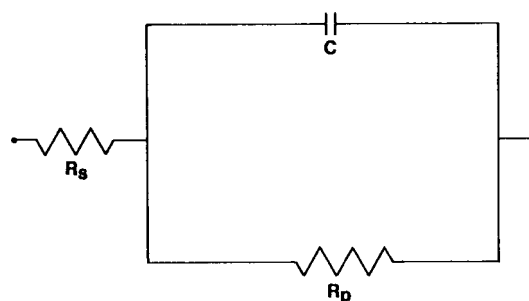

FIG. X2.1 Circuit That Models Simple Impedance Response

corrosion potential. By combining R_p with the Tafel slopes for the half-cell reactions by an equation such as the Stern-Geary equation (8), the corrosion rate can be estimated. Thus, analysis of electrochemical impedance enables the corrosion rate to be estimated rapidly in the absence of uncompensated solution resistance when the measurement is made at the corrosion potential. Methods of plotting these data are shown in Practice G 3. Unfortunately, corrosion processes exist which are not as simple as the case just discussed. These more complex processes can still be analyzed.

X3. DIFFUSION CONTROL

X3.1 Sometimes the rate of a chemical reaction can be influenced by the diffusion of one or more reactants or products to or from the surface. This situation can arise when diffusion through a surface film or hydrodynamic boundary layer becomes the dominating process. Examples are the surface being covered with reaction products of limited solubility. An example of this type of corrosion process that has extreme practical importance is the corrosion of carbon steel in concentrated sulfuric acid in which the product FeSO_4 has limited solubility. Such corrosion has been shown to be controlled by the diffusion of FeSO_4 from a saturated film at the surface to the bulk fluid (10). Another example is corrosion of steel in water in which the mass transfer of dissolved oxygen can control the corrosion rate (5).

X3.2 Very often, electrochemical impedance data for such systems has a unique characteristic known as the Warburg impedance. In the low frequency limit, the current is a constant 45° out-of-phase with the potential excitation (4, 5). The impedance response should ultimately deviate from this relationship. It will return to the real axis at very low frequencies that may be impossible to measure (11).

X3.3 The equivalent circuit is shown in Fig. X3.1. The term W is the Warburg impedance. By appropriate manipulation of the data, the values of the circuit elements can be evaluated (4, 5). These circuit elements can be used to obtain a value for a resistance (charge transfer resistance) that can sometimes be related to a corrosion rate (12).

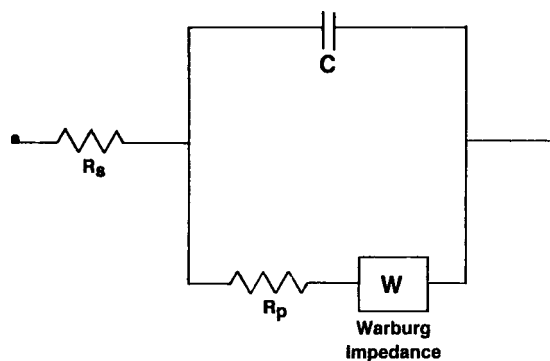

FIG. X3.1 Circuit That Models Impedance In The Presence of Diffusion

X4. INDUCTANCE

X4.1 Sometimes, the Nyquist type plot exhibits a low frequency portion lying in the fourth quadrant. This behavior seems to have one of a number of causes (5, 13-16), for example, some type of equilibrium adsorption of a reaction intermediate followed by a rapid desorption of the product. This inductance may be named pseudo-inductance because the processes giving rise to this response are not necessarily the same as those in a real inductor (15). Indeed, sometimes the behavior is caused by the response not being linearly related to the excitation. Decreasing the amplitude of the excitation might eliminate the pseudo-inductive behavior. Care must be exercised when this behavior is observed.

X4.2 If there is one time constant, the circuit giving rise to the response might be modeled as shown in Fig. X4.1. Such a circuit can be solved as long as R_p can be estimated (12). The

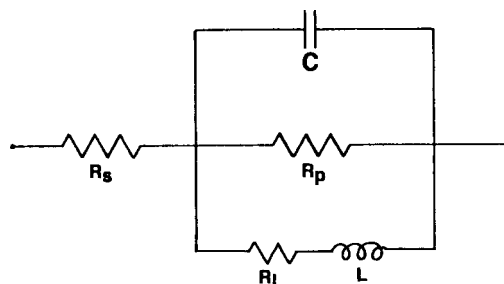

FIG. X4.1 Circuit That Models Impedance In The Presence Of Pseudo-Inductance

accuracy of the values of R_p and R_L so calculated can be ascertained by comparing the calculated Nyquist and Bode plots with the measured Nyquist and Bode plots. Thus the corrosion rate may be estimated in the presence of inductance.

X5. DEPRESSION OF NYQUIST SEMICIRCLE

X5.1 In real systems, the Nyquist type of semicircle for a simple corrosion process often exhibits some depression below the real axis. An example is shown in Fig. X5.1. This behavior has a number of potential causes. Some are improper cell design, surface roughness, dispersion of the time constant

caused by the reaction having more than one step, surface porosity, etc.

X5.2 The significance of this depression of the semicircle is the fact that Fig. X5.1 and not the Nyquist plot shown in Practice G 3 often represents the appearance of a real Nyquist plot of even a simple charge transfer process. Examples that can fit this characteristic are carbon steel in 1 M sulfuric acid and carbon steel in water. Thus, the ability to extract the polarization resistance from this type of curve is important if one is to use the data to estimate corrosion rates, especially when the cause of the depression is unclear. One type of circuit that can model such depression is given by:

$$Z = R_s + \frac{R_p}{1 + (j\omega\tau)^\alpha} \tag{X5.1}$$

X5.3 In Eq X5.1, the phenomenological term $(j\omega\tau)^\alpha$ replaces the term $j\omega R_p C$ when $\alpha < 1$. In the simple response described by the circuit in Fig. X1.4, $\alpha = 1$. The exponent α accounts for the depression below the real axis. The value of R_p can still be estimated by curve-fitting the semicircle and by allowing both the radius and origin to vary (12, 17). Thus, corrosion rates can still be estimated even in the presence of such depression, whatever its cause. Controversy surrounds the physical meaning of (Eq X5.1).

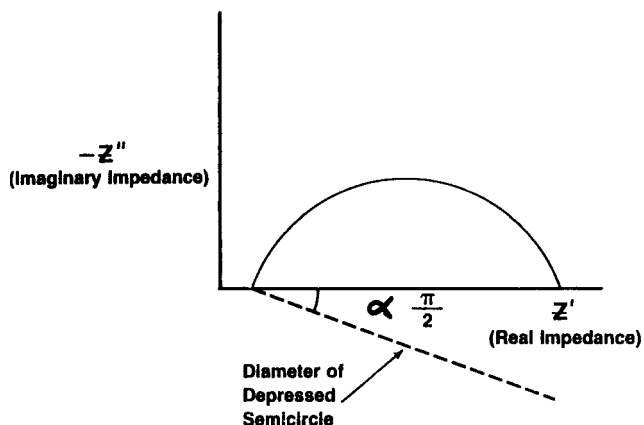

FIG. X5.1 Nyquist Type of Plot Showing Depression Below The Real Axis

X6. MORE COMPLEX PHENOMENA

X6.1 When a metal is coated with a porous non-conducting film, the equivalent circuit must simultaneously account for the polarization resistance caused by the corrosion process and the pore resistance. Sometimes, two or more time constants can arise for a corrosion process (18, 19). The cause can be a multi-step reaction in which both steps have comparable rates or an adsorbed intermediate, among others. These phenomena

require more complex equivalent circuits. However, the procedure for analyzing these complex responses still requires maintaining linearity between excitation and response, the proposal of an equivalent circuit, and then the examination of the predicted versus measured frequency response to verify the model. Even in these cases, the value of the polarization resistance can be estimated from an appropriate model so that

the corrosion rate and possibly mechanism might be determined and corrosion predictions can be made.

REFERENCES

- (1) McKubre, M. C. H., "Techniques for AC Impedance Measurements in Corrosion Systems," *CORROSION/87*, Paper 480, San Francisco, CA, March 1987, pp 9–13.
- (2) Cahan, B., Nagy, Z., and Genshaw, M., "Cell Design for Potentiostatic Measuring Systems," *Journal of the Electrochemical Society*, Vol 119, No. 1, 1972, p. 64.
- (3) Mansfeld, F., *Corrosion*, Vol 36, No. 5, 1981, p. 301.
- (4) "Basics of AC Impedance Measurements," EG&G Princeton Applied Research, Application Note AC-1.
- (5) Gabrielli, C., "Identification of Electrochemical Processes by Frequency Response Analysis," Solartron Instrumentation Group, 1980.
- (6) Macdonald, D. D., and McKubre, M. H., "Impedance Measurement in Electrochemical Systems," *Modern Aspects of Electrochemistry*, (Bockris, J. O'M., Conway, B. E., and White, R. E., ed.), Vol. 14, Plenum Press, New York, 1982, p. 61.
- (7) Hladky, K., Callow, L. M., and Dawson, J. L., *Br. Corrosion Journal*, Vol. 15, No. 1, 1980, p. 20.
- (8) Mansfeld, F., *Corrosion*, Vol. 29, 1973, p. 397.
- (9) Bockris, J.O'M, and Reddy, A. K. N., *Modern Electrochemistry*, Plenum Press, New York, 1970.
- (10) Ellison, B. T., and Schmeal, W. R., *Journal of the Electrochemical Society*, Vol 125, 1978, p. 524.
- (11) Dawson, J. L., and John, D. G., *Journal of Electroanalytical Chemistry*, Vol 110, 1980, p. 37.
- (12) Silverman, D. C., and Carrico, J. E., *Corrosion*, Vol 44, No. 5, 1988, p. 280.
- (13) Lorenz, W. J., and Mansfeld, F., *Corrosion Science*, Vol 21, No. 9, 1981, p. 647.
- (14) Epelboin, I., Keddam, M., and Takenouti, H., *Journal of Applied Electrochemistry*, Vol 2, 1972, p. 71.
- (15) Armstrong, R. D., and Edmondson, K., *Electrochimica Acta*, Vol 18, 1973, p. 937.
- (16) Macdonald, D. D., *Journal of the Electrochemical Society*, Vol 125, No. 12, 1978, p. 2062.
- (17) Kendig, M. W., Meyer, E. M., Lindberg, G., and Mansfeld, F., *Corrosion Science*, Vol 23, No. 9, 1983, p. 1007.
- (18) Mansfeld, F., "Evaluation of Corrosion Protection Methods With Electrochemical Impedance Spectroscopy," *Corrosion/87*, paper 481, San Francisco, March 1987.
- (19) Armstrong, R. D., Bell, M. F., and Metcalfe, A. A. "The AC Impedance of Complex Electrochemical Reactions," *Electrochemistry*, Vol 6, The Chemical Society, Burlington House, London, 1976, p. 98.

The American Society for Testing and Materials takes no position respecting the validity of any patent rights asserted in connection with any item mentioned in this standard. Users of this standard are expressly advised that determination of the validity of any such patent rights, and the risk of infringement of such rights, are entirely their own responsibility.

This standard is subject to revision at any time by the responsible technical committee and must be reviewed every five years and if not revised, either reapproved or withdrawn. Your comments are invited either for revision of this standard or for additional standards and should be addressed to ASTM Headquarters. Your comments will receive careful consideration at a meeting of the responsible technical committee, which you may attend. If you feel that your comments have not received a fair hearing you should make your views known to the ASTM Committee on Standards, 100 Barr Harbor Drive, West Conshohocken, PA 19428.

This standard is copyrighted by ASTM, 100 Barr Harbor Drive, West Conshohocken, PA 19428-2959, United States. Individual reprints (single or multiple copies) of this standard may be obtained by contacting ASTM at the above address or at 610-832-9585 (phone), 610-832-9555 (fax), or service@astm.org (e-mail); or through the ASTM website (<http://www.astm.org>).