

Steel sleepers

ICS 45.080

Committees responsible for this British Standard

The preparation of this British Standard was entrusted to Technical Committee RAE/2, Railway track components, upon which the following bodies were represented:

British Precast Concrete Federation
Confederation of British Forgers
London Underground Ltd.
Prestressed Concrete Association
Railtrack
Railway Industry Association
Society of Chemical Industry
Timber Trade Federation
UK Steel Association

This British Standard, having been prepared under the direction of the Engineering Sector Committee, was published under the authority of the Standards Committee and comes into effect on 15 November 2000

© BSI 11-2000

First published November 1956
Second edition November 2000

The following BSI references relate to the work on this standard:
Committee reference RAE/2
Draft for comment 97/710769 DC

ISBN 0 580 33178 4

Amendments issued since publication

Amd. No.	Date	Comments

Contents

	Page
Committees responsible	Inside front cover
Foreword	ii
<hr/>	
1 Scope	1
2 Normative references	1
3 Information and requirements to be agreed and to be documented	1
3.1 General	1
3.2 Information to be supplied by the purchaser	1
3.3 Information to be supplied by the manufacturer when tendering to supply	2
4 Sleeper dimension	2
5 Type approval tests	2
5.1 Cyclic loading resistance	2
5.2 Lateral resistance	2
5.3 Electrical resistance	2
6 Marking	2
<hr/>	
Annex A (informative) Advice on achieving and verifying product consistency	3
Annex B (informative) Estimation of the maximum rail seat reactions and lateral forces	4
Annex C (normative) Cyclic loading test procedure	5
Annex D (normative) Method of determining sleeper lateral resistance	10
Annex E (normative) Method of measuring electrical resistance	11
Annex F (normative) Specification for ballast	12
<hr/>	
Bibliography	13
<hr/>	
Figure C.1 — Cyclic loading test arrangement	8
Figure C.2 — Detail of thrust arm	9
Figure D.1 — Ballast box dimensions	10
Figure E.1 — Electrical resistance test arrangement	12
<hr/>	
Table F.1 — Ballast sizes	12
<hr/>	

Foreword

This British Standard has been prepared by Technical Committee RAE/2. It supersedes BS 500:1956, which is withdrawn. The standard differs radically from previous editions in that it is performance based and is intended to provide the supplier with the maximum flexibility in design and manufacture compatible with achieving a consistent and satisfactory service performance.

Extracts from Railtrack Line Specification RT/CE/S/021, *Steel Sleepers*, are used with permission.

Assessed capability. Users of this British Standard are advised to consider the desirability of quality system assessment and registration against BS EN ISO 9001 or BS EN ISO 9002 by an accredited third-party certification body (see annex A).

A British Standard does not purport to include all the necessary provisions of a contract. Users of British Standards are responsible for their correct application.

Compliance with a British Standard does not of itself confer immunity from legal obligations.

Summary of pages

This document comprises a front cover, an inside front cover, pages i and ii, pages 1 to 13 and a back cover.

The BSI copyright notice displayed in this document indicates when the document was last issued.

1 Scope

This British Standard specifies performance requirements for steel sleepers for railway track. It includes definitive requirements relating to the ability of the sleeper to retain track geometry, sleeper durability, electrical resistance, and the control of the production process so that the consistency of the sleeper's performance is assured.

2 Normative references

The following normative documents contain provisions which, through reference in this text, constitute provisions of this British Standard. For dated references, subsequent amendments to, or revisions of, any of these publications do not apply. For undated references, the latest edition of the publication referred to applies.

BS 812-103.1, *Testing aggregates — Part 103: Method for determination of particle size distribution — Section 103.1: Sieve tests.*

BS 812-105.1:1989, *Testing aggregates — Part 105: Methods for determination of particle shape — Section 105.1: Flakiness index.*

BS 812-105.2:1990, *Testing aggregates — Part 105: Methods for determination of particle shape — Section 105.2: Elongation index of coarse aggregate.*

BS 6072:1981, *Method for magnetic particle flow detection.*

BS EN 27888:1993, *Water quality — Method for the determination of electrical conductivity.*

BS EN ISO 7500-1:1999, *Metallic materials — Verification of static uniaxial testing machines — Part 1: Tension/compression testing machines — Verification and calibration of the force-measuring system.*

3 Information and requirements to be agreed and to be documented

3.1 General

For compliance with the standard, both the definitive requirements specified throughout the standard and the following documented items shall be satisfied.

3.2 Information to be supplied by the purchaser

3.2.1 Fastening system specified by purchaser

If the purchaser specifies the fastening system to be used, the following information shall be supplied and fully documented:

- a) the rail fastening system to be used (including the rail pad and any insulators) and whether its components are to be supplied with the sleeper;
- b) the nominal track gauge;
- c) the rail profile to be used;
- d) the nominal rail inclination;
- e) the maximum static and dynamic rail seat reactions and the maximum lateral force to be supported (see annex B);
- f) any specific requirements to ensure that installation of the sleepers and track maintenance can be undertaken effectively using the procedures available to the purchaser;
- g) any specific requirements for the packaging and protection of sleepers in transit;
- h) whether an electrical resistance test is required and the minimum resistance to be achieved.

3.2.2 Fastening system not specified by purchaser

If the purchaser does not specify the fastening system to be used, the following information shall be supplied and fully documented:

- a) whether the fastening system is to be supplied with the sleeper as an assembled unit;
- b) the nominal track gauge and the acceptable variation;
- c) the rail profile to be used;
- d) the nominal rail inclination and its acceptable variation;
- e) the maximum static and dynamic rail seat reaction, and the maximum lateral force to be supported (see annex B);
- f) any specific requirements to ensure that installation of the sleepers and track maintenance can be undertaken effectively using the procedures available to the purchaser;
- g) any specific requirements for the packaging and protection of sleepers in transit;
- h) whether an electrical resistance test is required and the minimum resistance to be achieved.

3.3 Information to be supplied by the manufacturer when tendering to supply

The following information shall be supplied by the manufacturer and fully documented:

- a) a dimensioned and toleranced drawing of the sleeper that is to be supplied;
 - b) the sleeper mass;
 - c) a statement of how the manufacturer will ensure that all sleepers meet the requirements of this specification. Sufficient detail, including the grade of steel, shall be provided to enable the purchaser or a third party to verify that the manufacturer is adhering to the stated method;
- NOTE Advice on achieving a consistent and verifiable performance is given in annex A.
- d) the results of the cyclic loading tests specified in 5.1;
 - e) the results of the sleeper lateral resistance measurements specified in 5.2;
 - f) if electrical isolation of the rail from the sleeper is required, the results of the electrical resistance test specified in 5.3;
 - g) the method by which any specific requirements of the purchaser in relation to installation of the sleepers in track and the subsequent maintenance of the track have been met [3.2.1f)];
 - h) where the purchaser has no specific packaging or protection arrangements, the method of packaging which will be used, including stack size;
 - i) if the purchaser has specified the fastening system, the maximum and minimum track gauge and rail inclination possible.

4 Sleeper dimension

The soffit width shall be such that the ballast pressure under a force equal to the maximum static rail seat reaction shall not exceed 0.5 MN/m^2 , assuming this load to be uniformly distributed over a length of 0.8 m, unless otherwise specified by the purchaser (see B.5.1). To ensure that this can be achieved, the sleeper soffit shall be continuous for at least 450 mm on either side of the rail seat centre line except for small apertures necessary for fastening attachment.

5 Type approval tests

5.1 Cyclic loading resistance

The cyclic loading resistance determined in accordance with annex C shall be not less than 2.4 times the dynamic rail seat reaction [see 3.2.1e)].

This test shall be repeated when there is any change in the sleeper design or manufacturing process which might affect fatigue performance.

NOTE The results of the tests required by annex C are reported in terms of the total vertical load, i.e. twice the rail seat reaction. An additional factor of 1.2 has been applied to allow for the potential loss of section in service through corrosion.

5.2 Lateral resistance

The lateral resistance of the sleeper in a ballast box containing **uncompacted** ballast shall be not less than 4.5 kN when tested in accordance with annex D.

5.3 Electrical resistance

If the rail is to be electrically insulated from the sleeper, the resistance of the assembly shall be tested in accordance with annex E.

6 Marking

Sleepers shall be durably marked with the following information:

- a) the identification mark of the manufacturer;
- b) the last two figures of the year of manufacture;
- c) the sleeper type.

The marking shall be clearly visible with the sleeper installed in track.

Annex A (informative)

Advice on achieving and verifying product consistency

A.1 General

Subclause 3.3c) requires the manufacturer to submit to the purchaser a statement of the means to ensure that the performance requirements of this specification are consistently achieved.

It is recommended that the primary route to product performance and consistency is control of materials and of the production process. Areas where particular attention should be paid are given in A.2 to A.5 below.

Verification by test, for example the measurement of critical dimensions, is always necessary but the frequency of such testing may be relaxed as confidence in the control of the production process grows.

Repetition of the tests undertaken prior to tender to demonstrate the product's performance is only necessary if the design, materials or the production process is changed from that used to produce the sleepers tested to provide the data reported in accordance with clause 3.

A.2 Quality assurance

In order that adherence to the procedures used to ensure consistency can be verified, it is necessary that they can be documented. This is best achieved through the implementation of a formal quality system. It is recommended that:

- the sleeper designer should operate an independently approved and audited quality system conforming to the requirements of BS EN ISO 9001;
- the sleeper manufacturer should operate an independently approved and audited quality system conforming to the requirements of BS EN ISO 9002;
- all testing should be undertaken by a test house operating an independently approved and audited system procedure conforming to the requirements of BS EN ISO 9002 or BS 7501;

and that the adoption of these standards forms part of the submission.

A.3 Materials and processing

The statement should define the steel grade to be used and the steps that the supplier will take to verify the steel conforms to the specification.

EXAMPLE

“Sleepers shall be manufactured from steel conforming to EN 10025-72, grade Fe360B OPT BS: chemical composition and tensile properties shall be determined once per cast”.

The production process should also be defined.

EXAMPLE

“Sleepers shall be hot-rolled to shape with a finishing temperature of... . Spade ends will be cold formed”.

A.4 Attachment of rail fastenings

The fatigue strength of the sleeper will usually be crucially dependent on the method of attachment of the rail fastenings. Where a welded attachment is used, the welding process and procedure should be stated and the nature and frequency of post welding quality checks, for example magnetic particle inspection or verification of the throat thickness. The consumables to be used should be defined.

If the fastenings or their housings are to be attached by holes, the method of producing the holes (drilling, punching, etc.) should be stated; also whether de-burring will be undertaken and the checks to be made and their frequency to confirm the absence of cracks or tears in finished sleepers.

A.5 Geometry

The statement should include a demonstration (for example, drawings showing the effect of combining components at the limits of their permitted tolerance) that the requirements for gauge and rail inclination of clause 3.2.2b) and d) are met by the design, assuming nominal dimensions for the rail.

The statement should also describe the gauges or other means that will be used to verify that the key dimensions are within the required tolerances. Of particular importance are the rail seat inclination and the position of the rail fastening locating points.

The frequency with which key dimensions will be verified should be stated.

Annex B (informative)

Estimation of the maximum rail seat reactions and lateral forces

B.1 General

Where no information is available on the rail seat reactions to be expected at track irregularities, the following method of estimation is recommended.

B.2 Symbols

For the purposes of this annex the following symbols apply.

- d is the track gauge in millimetres (mm) +50 (mm);
- E is the Young's modulus for the rail in meganewtons per square metre (MN/m²);
- h_1 is the maximum cant deficiency for the vehicle concerned in millimetres (mm);
- h^* is the height of vehicle centre of gravity above rail top in millimetres (mm);
- I is the moment of inertia (second moment of area) of the rail (m⁴);
- k is the uniformly distributed force required to cause a uniform unit track deflection in meganewtons per metre, per metre of track (MN/m/m);
- K_{t2} is the wheel force required to cause unit deflection of the track in meganewtons per metre (MN/m);
- M is the unsprung mass of vehicle, per wheel in kilograms (kg);
- P_0 is the static wheel force in kilonewtons (kN);
- P_0' is the static wheel force in kilonewtons (kN);
- P_2 is the dynamic wheel force at top of track irregularity characterised by a dip angle of 2α , in kilonewtons (kN);
- q is the sleeper spacing in metres (m);
- R_d is the dynamic rail seat reaction in kilonewtons (kN);
- R_s is the static rail seat reaction in kilonewtons (kN);
- V is the train speed in metres per second (m/s);
- 2α is the the effective dip angle, measured in radians of the worst expected track top irregularity, i.e. the external angle between the two lines tangent to the rail top at the irregularity;

$$\beta = 4\sqrt{\left(\frac{k}{4EI}\right)}$$

B.3 Vehicles

Identify the vehicles having:

- the maximum static wheel load;
- the maximum vehicle speed;
- the maximum vehicle unsprung mass (per axle);
- the maximum height of the centre of gravity of any vehicle;
- the maximum cant deficiency;

which are expected to run on tracks equipped with the sleeper.

B.4 Dynamic wheel-rail force

For each of the vehicles identified in **B.3**, calculate the wheel-rail force perpendicular to the rail head as enhanced by curving P_0' in kilonewtons (kN) using the equation:

$$P_0' = P_0 \left(1 + \frac{2h_1 h^*}{d^2} \right)$$

Calculate the dynamic wheel-rail force P_2 , in kilonewtons (kN) at a track top irregularity from the equation:

$$P_2 = P_0' + 2\alpha V \sqrt{MK_{t2}}$$

NOTE 1 For usage in the UK a dip angle of 0.02 radians has been customarily assumed for bolted track and 0.01 radians for continuously welded track.

NOTE 2 For heavy section rails (46 kg/m linear mass or greater) and stone-ballasted track, the following empirical equation may be used for K_{t2} :

$$K_{t2} = 0.9 \left(\frac{P_0'}{q} \right)^{0.75}$$

Procedure: Use P_0' (as shown) to obtain a first estimate of P_2 , then use this value of P_2 to re-calculate K_{t2} and obtain a final value of P_2 .

B.5 Rail seat reactions

B.5.1 Static rail seat reaction

For each of the vehicles identified in B.3 calculate the static rail seat reaction (R_s in kN) from the equation:

$$R_s = P_0' \times 0.5q\beta$$

NOTE If steel sleepers of conventional design are used in conjunction with heavy section rails (46 kg/m linear mass or greater) and stone ballast, β may be estimated from the empirical equation:

$$\beta = 0.32 \left(\frac{P_0'}{q} \right)^{0.25}$$

B.5.2 Dynamic rail seat reaction

For each of the vehicles identified in B.3 calculate the dynamic rail seat reaction (R_d in kN) from the equation:

$$R_d = P_2 \times 0.5q\beta$$

NOTE If steel sleepers of conventional design are used in conjunction with heavy section rails (46 kg/m linear mass or greater) and stone ballast, β may be estimated from the equation:

$$\beta = 0.32 \left(\frac{P_2}{q} \right)^{0.25}$$

B.6 Sleeper serviceability

The highest values of R_s and R_d should be used to assess the compliance of the sleeper design with the requirements relating to ballast pressure (see clause 4) and cyclic loading (see 5.1) respectively.

B.7 Lateral force per rail seat

For UK mainline railway operations a maximum value of 35 kN may be assumed. Where no other information exists a value of 40 kN should be assumed.

Annex C (normative)

Cyclic loading test procedure

C.1 General

This procedure shall be used to determine the fatigue limit of specific sleeper designs so that their serviceability, when subjected to a specific usage, can be determined.

NOTE The test procedure used imposes both vertical and lateral forces on the rail seats.

C.2 Symbols

For the purposes of this annex the following symbols apply.

b	is the step size in kilonewtons (kN), being the difference in the force maxima applied in successive tests;
\bar{F}	is the mean fatigue limit in kilonewtons (kN);
F_m	is the maximum force in kilonewtons (kN) used in the test;
F_0	is the lowest maximum force in kilonewtons (kN) resulting in the less frequent result;
i	is the force level (i is the 0 for F_0) in kilonewtons (kN);
n	is the total number of the less frequent result (failure or run-out);
n_i	is the number of the less frequent events at the i th force level above F_0 ;
s	is the standard deviation of the fatigue limit in kilonewtons (kN);
z	is the number of stress levels above F_0 .

C.3 Apparatus

C.3.1 *Sleeper support pads*, rubber or another polymeric material, with the following characteristics:

- compliance, when loaded uniformly, in the range 0.025 mm/kN to 0.035 mm/kN;
- length of at least 800 mm;
- width greater than the full width of the sleeper soffit;
- thickness no more than 0.25 times the soffit width.

C.3.2 *Mounting blocks*, steel, the top face of which geometrically conforms to that of the sleeper soffit.

C.3.3 *Rail pads*, having a stiffness of at least 150 kN/mm.

C.4 Test arrangement

Load and support the sleeper as shown in Figures C.1 and C.2. The angle of the thrust arms shall be established with the maximum test load applied.

Position the support pads (C.3.1) so that they support the sleeper as far as the spade end radius. The pads themselves shall be supported by steel blocks (C.3.2). Rail pads (C.3.3) shall be interposed between the rail foot and the rail seat of the sleeper.

NOTE It is recommended that the stiffness of the support pads is verified dynamically at the start of each test.

C.5 Force measurement

Measure the force applied using a fatigue rated load cell verified to BS EN ISO 7500-1:1999, Class 1.0.

C.6 Test end point

A “run-out” is a test in which, after 5×10^6 cycles, no crack longer than 3 mm can be found by magnetic particle inspection in accordance with BS 6072:1981.

A “failure” is a test in which a crack longer than 3 mm is detected either visually, or by magnetic particle inspection in accordance with BS 6072:1981, at any stage in the test up to the point at which 5×10^6 cycles have been applied.

Each test will result in either a run-out or a failure.

C.7 Test procedure

Apply cyclic forces to the sleeper at a frequency not exceeding 10 Hz. Use a sinusoidal or triangular waveform. Keep the ratio of the minimum to the maximum applied force at or below 0.1. Maintain the indicated force maximum within 2 % of its intended value.

NOTE If the pads overheat the frequency of the tests should be reduced.

Stop the test when either a crack becomes visible or 5×10^6 force cycles have been applied. If 5×10^6 cycles have been applied, use magnetic particle inspection in accordance with BS 6072:1981 to facilitate the detection of cracks.

In the first test, apply a maximum force (F_m) corresponding to the estimated mean fatigue limit.

- If the test ends in a failure reduce the maximum force applied in the next test by $0.05F_m$.
- If the test ends in a run-out increase the maximum force applied in the next test by $0.05F_m$.

After each subsequent test that ends in a failure, reduce the maximum force applied in the next test by $0.05F_m$.

After each subsequent test ends in a run-out, increase the maximum force applied in the next test by $0.05F_m$.

Continue testing until either:

- a) results are available for at least three stress range levels with results of both types, i.e. both a failure and a runout, obtained at an intermediate test level. Ten results shall be obtained; or
- b) at least six results are obtained which alternate between failure and run-out at two neighbouring stress levels.

C.8 Test record

The following shall be recorded:

- the maximum force applied in each test;
- whether the result was a failure or a run-out;
- if the result was a failure, the crack location;
- date of test;
- laboratory performing test;
- sleeper type;
- identification marks on the sleepers tested.

C.9 Data analysis

Calculate the mean fatigue limit, \bar{F} in kN/mm² using the equation:

$$\bar{F} = F_0 + b \left(\frac{A}{n} \pm 0.5 \right)$$

where

$$b = 0.05 F_m$$

and

$$A = \sum_{i=0}^z i n_i$$

Use +0.5 in the formula for the mean fatigue limit if the less frequent event is a run-out and -0.5 if the less frequent event is a failure.

Calculate the standard deviation s in kilonewtons (kN) using the formula:

$$s = 1.62b \left(\frac{Bn - A^2}{n^2} + 0.029 \right)$$

where

$$B = \sum_{i=0}^z i^2 n_i$$

This formula holds if the standard deviation is greater than $0.533b$. If this condition is not met then the standard deviation is small and shall be deemed acceptable.

If the exceptional situation defined in C.7 occurs, the mean fatigue limit (\bar{F}) may be taken as the average of the highest force level at which run-outs occur and the lowest force level at which failures occur. Under these circumstances the higher and lower force levels represent approximately the 95 % confidence limits for the estimation of the mean of the population. For the purposes of defining the lower admissible fatigue threshold the standard deviation may be taken as less than $b/2$. This is a conservative estimate as the observed result has greater probability with smaller standard deviation, however more accurate determination of the standard deviation requires testing at more levels to confirm a lower value with statistical confidence.

Example

An example of the analysis of data from a fatigue test using the staircase method.

The type of results to be expected are exemplified in the table below.

Load kN	1	2	3	4	5	6	7	8	9	10	i	n_i	$i n_i$	$i^2 n_i$
230			X								2	1	2	4
220		O		X				X			1	2	2	2
210	O				X		O		O		0	1	0	0
200						O								
											n	4		
											A		4	
											B			6

Failures (X) 4 less frequent event

Run-outs (O) 5

The lowest load range at which a failure occurs is 210 kN. As failure is the less frequent event, the form of equation to be used for the mean is:

$$\bar{F} = F_0 + b \left(\frac{A}{n} - 0.5 \right)$$

$$\bar{F} = 210 + 10 \left(\frac{4}{4} - 0.5 \right) = 215 \text{ kN}$$

The standard deviation is:

$$s = 1.62b \left(\frac{Bn - A^2}{n^2} + 0.029 \right)$$

$$s = 1.62 \times 10 \left(\frac{6 \times 4 - 4^2}{4^2} + 0.029 \right) = 8.57 \text{ kN}$$

C.10 Cyclic loading resistance

The cyclic loading resistance shall be taken as the mean minus two standard deviations value of the maximum force applied at the fatigue limit

NOTE It is implicit in the test method described above that the ratio of the maximum lateral force applied to the sleeper to the maximum dynamic rail seat reaction is constant and approximately 0.38. This is based on the ratio of the lateral and vertical sleeper forces (L/V) expected to be generated by a two axle wagon with poor curving performance and a nominal axle load approaching 250 kN, traversing a 400 m radius curve of a poor vertical geometry. This represents the most severe usage expected in UK mainline railway operation. Thus the test provides results of direct relevance to UK applications.

For other applications, other ratios of L/V may be appropriate and in these cases the test results obtained above need to be adjusted to allow for this.

In the event of the range of L/V values differing from those included in the fatigue test specification, the supplier and purchaser may agree on the compatibility between the test results and their use for the given application based on a review of the duty for which the sleepers are intended. This review may conclude:

- that the levels of duty are generally lower or similar to the levels envisaged by the test procedure and that no additional testing is necessary;
- the sensitivity of the failure criterion (critical stress at a critical location) to different L/V ratios requires that an additional evaluation of performance is required. This may take as its basis the use of strain measurement or calculation to predict the range of L/V and V values for which a sleeper is acceptable, or alternatively further fatigue tests, or other method agreed by the parties.

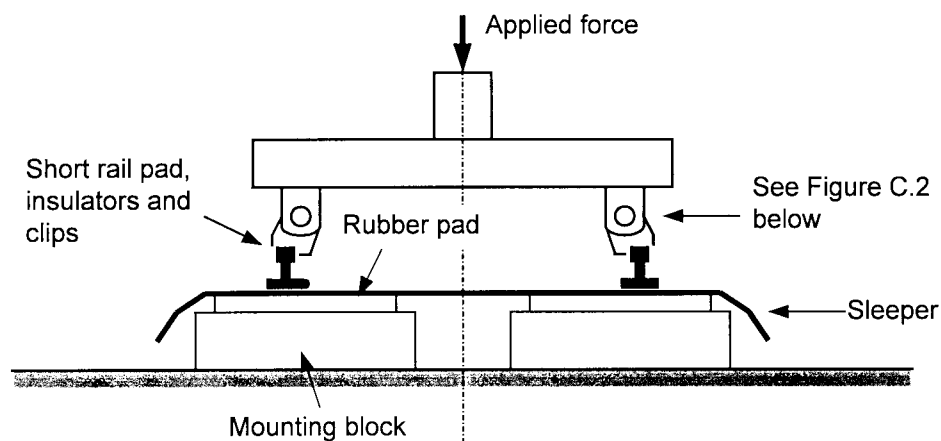
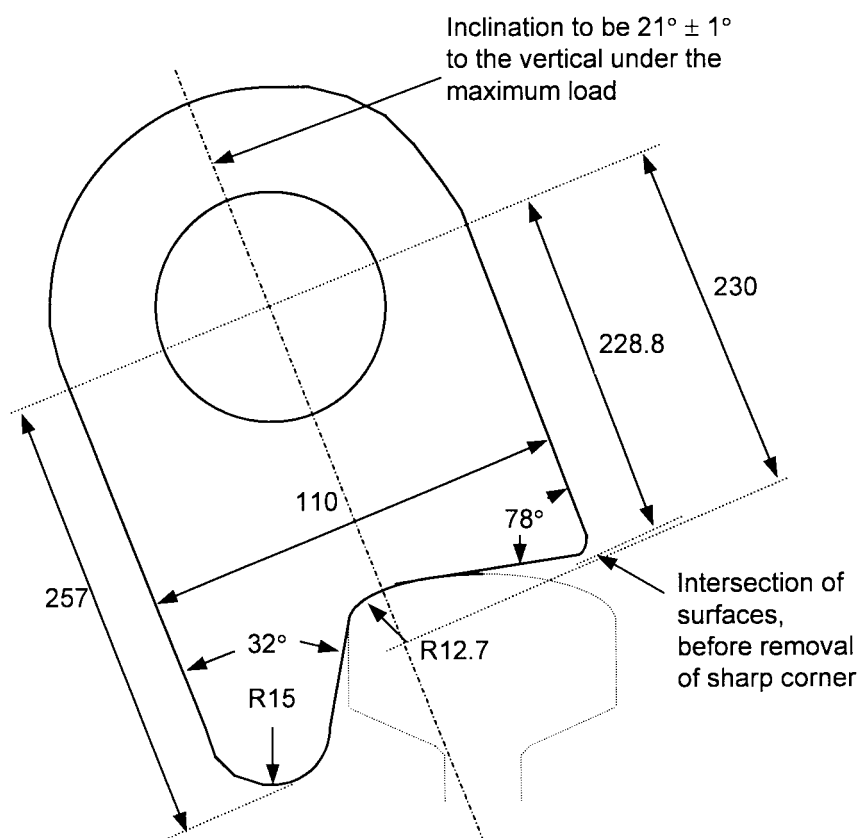

Figure C.1 — Cyclic loading test arrangement

Dimensions in millimetres



NOTE 1 Recommended surface hardness of thrust arm where in contact with rail head: 58/60 HRC.

NOTE 2 The dimensions 257, 228.8 and 230 are minima and may be increased by equal amounts

Figure C.2 — Detail of thrust arm

Annex D (normative)

Method of determining sleeper lateral resistance

Undertake the test in a ballast box with the dimensions shown in Figure D.1; the box width shall be at least 600 mm greater than the maximum width of the sleeper

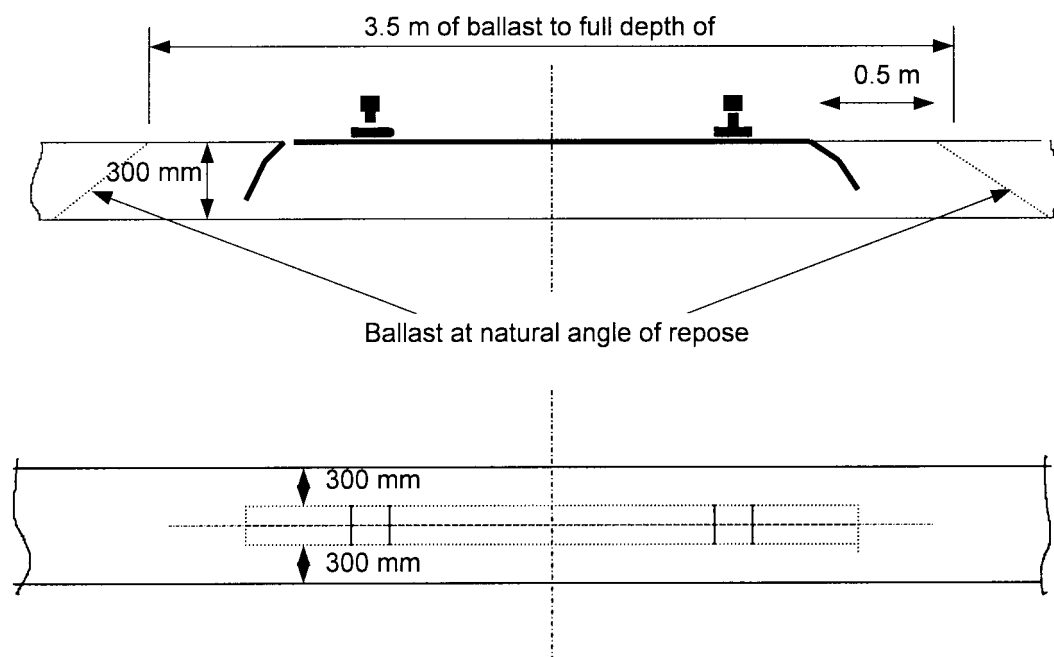

Figure D.1 — Ballast box dimensions

The ballast shall conform to the requirements of annex F.

The test sleeper, assembled with all pads, insulators and fastenings and stub rails of the relevant profile, of lengths equal to the appropriate sleeper spacing, shall be tamped or vibrated into the ballast to ensure that the sleeper is filled with ballast. The top surfaces of the test sleeper and the ballast shall be flush with the top of the box. Remove ballast beyond the sleeper ends to produce the profile shown in Figure D.1.

NOTE Alternatively shorter stub rails could be used with additional mass provided to achieve the equivalent overall weight.

Move the sleeper parallel to its longitudinal axis through a distance of 30 mm at a rate of (10 ± 2) mm/min and measure the force applied at displacements of 25 mm and 30 mm using a load cell verified to BS EN ISO 7500-1. The force application shall be via the rail fastening.

Remove the sleeper, disturb the ballast throughout the box using a fork and repeat the test sequence six times. The sleeper's lateral resistance is the lowest quartile value of the average of the force measured at 25 mm and 30 mm displacement.

Annex E (normative)

Method of measuring electrical resistance

E.1 Principle

The current flowing between two short lengths of rail fastened to a sleeper is measured whilst the whole sleeper and fastenings are sprayed with water at a controlled rate. Correction is made for the conductivity of the water.

E.2 Test piece

A sleeper shall be assembled with all pads, insulators and fastenings and short lengths of rail on both rail seats. The rails shall extend at least as far as the edge of the sleeper.

E.3 Water

A water supply at a pressure of 1 kN/m² is required, having a known conductivity in the range 20 mS/m to 80 mS/m at a temperature of (15 ± 5) °C measured in accordance with BS EN 27888.

E.4 Spray equipment

The equipment shall be set up as shown in Figure E.1. It incorporates 4 nozzles.

The nozzles shall have a diameter of (3.6 ± 0.4) mm and a spray cone of 100° to 125°. A means of controlling and measuring the flow of water to each nozzle is required.

NOTE Systems in which the spray frame moves parallel to the rails during the test may be used provided that the mean position of the frame is centred over the sleeper and the amplitude of movement does not exceed 0.5 m.

E.5 Procedure

The test shall be carried out under cover and protected from rain and draughts in a room which is ventilated and has an air temperature of 15 °C to 30 °C. Support the sleeper, which shall be surface dry, on two electrically insulating blocks, not less than 50 mm thick, directly beneath the spray frame.

Spray water at a rate of 8 l/min from each nozzle for 2 min. Allow the assembly to drain and dry for 24 h. Clean a zone on each rail head. Apply an alternating voltage of 40 V RMS at a frequency of 50 Hz to 60 Hz between the two rails then spray again for 2 min. Measure the RMS current flowing during spraying and for not less than 10 min after spraying has ceased.

Record the maximum value. Estimate the value for a water conductivity of 33 mS/m from the equation:

$$i_{33} = i_{\max} \left(\frac{33}{c} \right)$$

where

- i_3 is the the estimated maximum current flow with a water conductivity of 33 mS/m;
- i_{\max} is the measured maximum current flow;
- c is the conductivity of the water used in mS/m.

Repeat the test on two other test pieces.

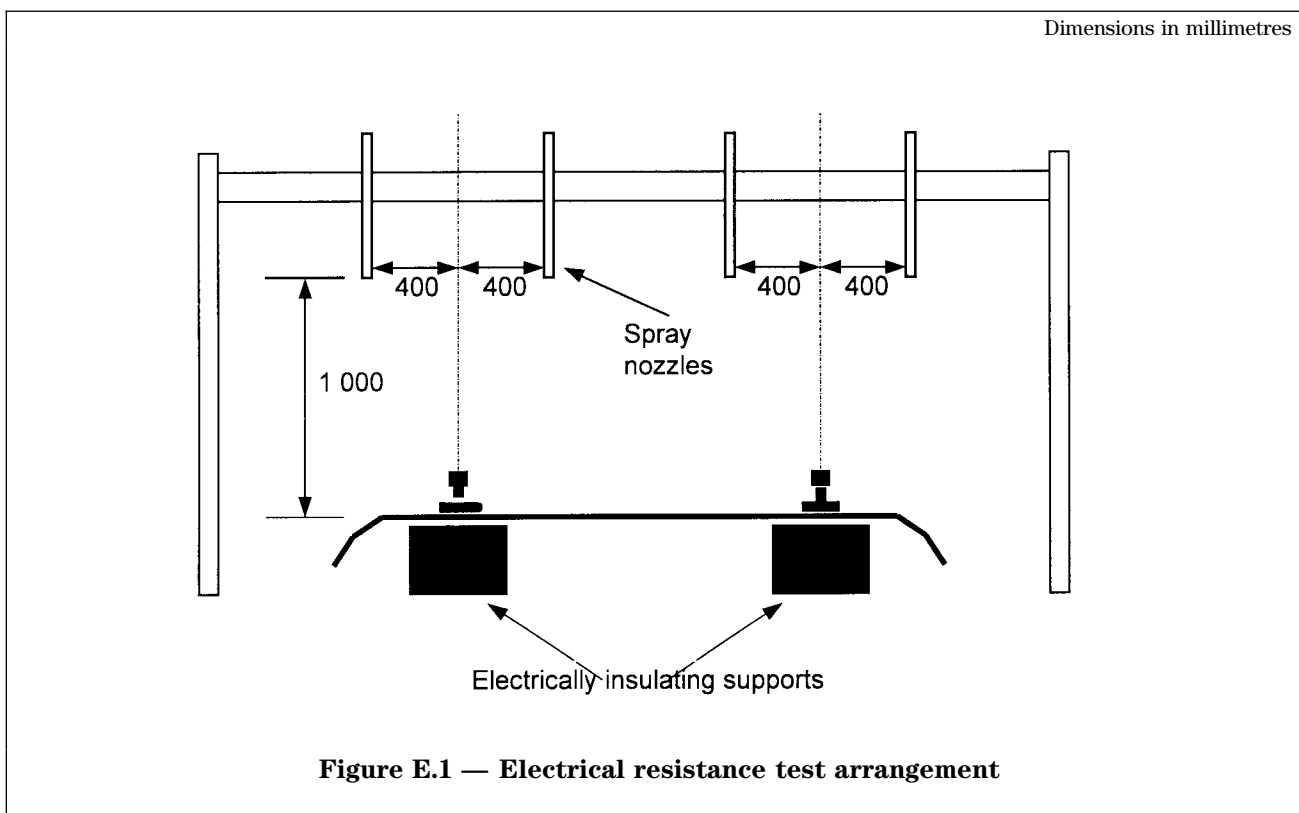

Annex F (normative)

Specification for ballast

F.1 Material

The ballast shall be hard, durable, natural stone of a quality which satisfies the requirements of **F.2** and **F.3**. The ballast shall be angular in shape, with all dimensions nearly equal. The ballast shall be free from dust, chemical contamination, and cohesive particles.

F.2 Dimensions

The ballast shall have a consistent mixture of sizes mainly between 50 mm and 28 mm to conform to the limits of Table F.1.

Table F.1 — Ballast sizes

Square mesh sieve mm	Cumulative % by weight passing BS sieve
63	100
50	100 to 97
37.5	65 to 35
28	20 to 0
14	2 to 0
1.18	0.8 to 0

The sieve test shall be as specified in BS 812-103.1:1985.

F.3 shape

F.3.1 Flakiness index

The flakiness index shall not exceed 40 % as measured by the test specified in BS 812-105.1:1989.

F.3.2 Elongation index

The elongation index shall not exceed 50 % as measured by the test specified in BS 812-105.2:1990.

Bibliography

BS 7501:1989, *General criteria for the operation of testing laboratories.*

BS EN ISO 9001:1994, *Quality systems — Model for quality assurance in design, development, production, installation and servicing.*

BS EN ISO 9002:1994, *Quality systems — Model for quality assurance in production installation or servicing.*

BSI — British Standards Institution

BSI is the independent national body responsible for preparing British Standards. It presents the UK view on standards in Europe and at the international level. It is incorporated by Royal Charter.

Revisions

British Standards are updated by amendment or revision. Users of British Standards should make sure that they possess the latest amendments or editions.

It is the constant aim of BSI to improve the quality of our products and services. We would be grateful if anyone finding an inaccuracy or ambiguity while using this British Standard would inform the Secretary of the technical committee responsible, the identity of which can be found on the inside front cover. Tel: 020 8996 9000. Fax: 020 8996 7400.

BSI offers members an individual updating service called PLUS which ensures that subscribers automatically receive the latest editions of standards.

Buying standards

Orders for all BSI, international and foreign standards publications should be addressed to Customer Services. Tel: 020 8996 9001. Fax: 020 8996 7001.

In response to orders for international standards, it is BSI policy to supply the BSI implementation of those that have been published as British Standards, unless otherwise requested.

Information on standards

BSI provides a wide range of information on national, European and international standards through its Library and its Technical Help to Exporters Service. Various BSI electronic information services are also available which give details on all its products and services. Contact the Information Centre. Tel: 020 8996 7111. Fax: 020 8996 7048.

Subscribing members of BSI are kept up to date with standards developments and receive substantial discounts on the purchase price of standards. For details of these and other benefits contact Membership Administration. Tel: 020 8996 7002. Fax: 020 8996 7001.

Copyright

Copyright subsists in all BSI publications. BSI also holds the copyright, in the UK, of the publications of the international standardization bodies. Except as permitted under the Copyright, Designs and Patents Act 1988 no extract may be reproduced, stored in a retrieval system or transmitted in any form or by any means – electronic, photocopying, recording or otherwise – without prior written permission from BSI.

This does not preclude the free use, in the course of implementing the standard, of necessary details such as symbols, and size, type or grade designations. If these details are to be used for any other purpose than implementation then the prior written permission of BSI must be obtained.

If permission is granted, the terms may include royalty payments or a licensing agreement. Details and advice can be obtained from the Copyright Manager. Tel: 020 8996 7070.