

Fans for general purposes —

Part 4: Dimensions

ICS 23.120

Committees responsible for this British Standard

The preparation of this British Standard was entrusted to Technical Committee MCE/17 Industrial fans, upon which the following bodies were represented:

Electricity Association
 Fan Manufacturers' Association
 Federation of Environmental Trade Associations
 HEVAC Association
 Ministry of Defence
 National Engineering Laboratory
 Power Generation Contractors' Association (BEAMA Ltd.)

This British Standard, having been prepared under the direction of the Engineering Sector Board, was published under the authority of the Standards Board and comes into effect on 15 January 1997

© BSI 11-1998

The following BSI references relate to the work on this standard:
 Committee reference MCE/17
 Draft for comment 94/706547 DC

ISBN 0 580 26376 2

Amendments issued since publication

Amd. No.	Date	Comments

Contents

	Page
Committees responsible	Inside front cover
National foreword	ii
<hr/>	
Introduction	1
1 Scope	1
2 Normative references	1
3 Definitions, symbols and abbreviations	1
4 Required characteristics	2
<hr/>	
Figure 1 — Impeller of a centrifugal fan	2
Figure 2 — Impeller of an axial-flow fan	2
Figure 3 — Impeller of a mixed-flow fan	2
Figure 4 — Circular flanges	4
Figure 5 — Rectangular flanges — Dimensions	7
<hr/>	
Table 1 — Fan sizes	2
Table 2 — Circular flanges — Dimensions for general purpose fans	5
Table 3 — Circular flanges — Dimensions for heavy duty fans	6
Table 4 — Rectangular flanges — Dimensions	8
Table 5 — A series of rectangular outlets based on the R20 series — Aspect ratios, k_p	9
Table 6 — A series of rectangular outlets based on the R20 series — Aspect ratios, k_g	10
<hr/>	
List of references	Inside back cover
<hr/>	

National foreword

This Part of BS 848 has been prepared by Technical Committee MCE/17 and is identical with ISO 13351:1996 *Industrial fans — Dimensions*, published by the International Organization for Standardization (ISO). ISO 13351 was prepared by Technical Committee ISO/TC 117 in which the United Kingdom played an active part.

Cross-references

Publication referred to	Corresponding British Standard
ISO 3:1973	BS 2045:1965 <i>Preferred numbers</i> (Technically equivalent)
(ISO 497:1973)	

A British Standard does not purport to include all the necessary provisions of a contract. Users of British Standards are responsible for their correct application.

Compliance with a British Standard does not of itself confer immunity from legal obligations.

Summary of pages

This document comprises a front cover, an inside front cover, pages i and ii, pages 1 to 10, an inside back cover and back cover.

This standard has been updated (see copyright date) and may have had amendments incorporated. This will be indicated in the amendment table on the inside front cover.

Introduction

This International Standard gives details of circular and rectangular flanges as well as specifying “fan size designation”. For circular flanges, the values specified in ISO 6580:1981, *General purpose industrial fans — Circular flanges — Dimensions* are retained for the next five years in parallel with those given in Table 2 of this International Standard.

Though not constraining a manufacturer’s choice of flange details, this International Standard provides the opportunity for interchangeability and therefore a reduction in technical obstacles to free trading.

Throughout this International Standard, the principal dimensions are based on the rounded values of “preferred” numbers given in ISO 497.

1 Scope

This International Standard specifies size designations for industrial fans and specifies dimensions for the circular and rectangular flanges of general purpose industrial fans as defined in 3.1.1. It does not apply to cross-flow fans, or fan appliances used for household or similar applications.

For circular flanges, this International Standard provides two different flange series, one for standard casing thicknesses and a second for heavy duty fans as used on board sea-going vessels or in heavy industry.

In order not to restrict fan designs unduly, only the pitch diameter, hole numbers and hole diameters are standardized. Flange thickness as well as internal and external flange diameters can be chosen freely within the limits of good engineering practice.

2 Normative references

The following standards contain provisions, which, through reference in this text, constitute provisions of this International Standard. At the time of publication, the editions indicated were valid. All standards are subject to revision, and parties to agreement based on this International Standard are encouraged to investigate the possibility of applying the most recent editions of the standards indicated below. Members of IEC and ISO maintain registers of currently valid International Standards.

ISO 3:1973, *Preferred numbers — Series of preferred numbers*.

ISO 497:1973, *Guide to the choice of preferred numbers and of series containing more rounded values of preferred numbers*.

ISO 13349:—¹⁾, *Industrial fans — Terminology*.

3 Definitions, symbols and abbreviations

3.1 Definitions

for the purposes of this International Standard, the definitions given in ISO 13349 and the following definitions apply

3.1.1 general purpose industrial fan

fan for which the flange dimensions conform to those given in Figure 4 and Table 2

3.1.2 heavy duty fan

fan for which the flange dimensions are greater and conform to those given in Figure 4 and Table 3

3.1.3 nominal impeller tip diameter, D

diameter of the impeller tip on which the design of the fan is based

3.2 symbols and abbreviations

for the purposes of this International Standard, the following symbols and abbreviations apply:

D	nominal impeller tip diameter (see Figure 1, Figure 2 and Figure 3)
D_R	actual impeller tip diameter (see Figure 1, Figure 2 and Figure 3)
d_1	pitch circle diameter
d_2	hole diameter
d_3	bolt diameter
d_4	washer diameter
e	casing thickness
g	hole offset
l	arc length between bolt holes
N	number of holes
α	a angle between bolt holes

¹⁾ To be published.

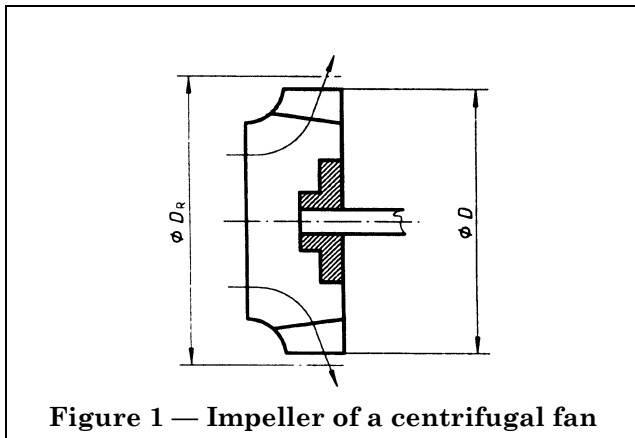

Figure 1 — Impeller of a centrifugal fan

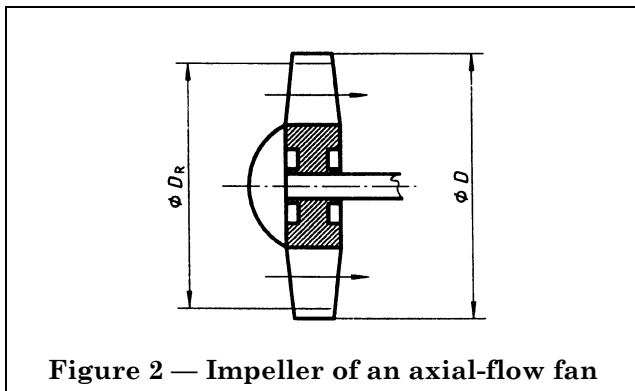

Figure 2 — Impeller of an axial-flow fan

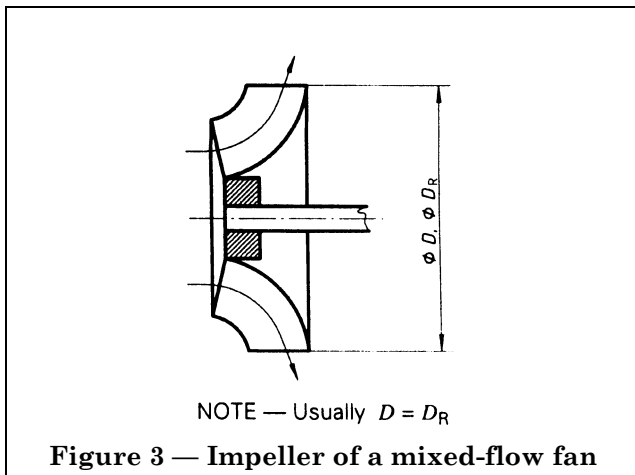

Figure 3 — Impeller of a mixed-flow fan

4 Required characteristics

4.1 General

This International Standard adopts the Renard R 20 Series as given in ISO 497 as the nominal dimensions for impeller tip diameters, inside diameters of circular flanges and the inside lengths of the sides of rectangular flanges. It takes into account the maximum casing thicknesses likely to be used for general purpose industrial fans as well as typical manufacturing tolerances representative of “good practice”.

The dimensions of circular and rectangular flanges are given in sizes which correspond to nominal diameters from 100 mm to 2 000 mm. In many cases, in the smaller sizes, below about 200 mm, flange details are determined by the customer’s specification. However, where this is not the case, then this International Standard shall be used.

4.2 Designation of fan size

Fan size shall be designated by the nominal impeller tip diameter as defined in 3.1.3.

This International Standard uses the R 20 Series (see ISO 3) for the fan size designation (nominal impeller tip diameter, D), in the range 100 mm to 2 000 mm, as shown in Table 1. For impeller tip diameters greater than 2 000 mm, the numbers may be selected from the R 20, R 40 or R 80 series.

Table 1 — Fan sizes

Dimensions in millimetres

Nominal impeller tip diameter D^a		
<u>100</u>	280	<u>800</u>
112	<u>315</u>	900
<u>125</u>	355	<u>1 000</u>
140	<u>400</u>	1 120
<u>160</u>	450	<u>1 250</u>
180	<u>500</u>	1 400
<u>200</u>	560	<u>1 600</u>
224	<u>630</u>	1 800
<u>250</u>	710	<u>2 000</u>

^a R 10 series numbers are underlined.

4.3 Circular flange characteristics

The smallest practical pitch circle diameter can be related to the inside diameter of the fan casing, the casing thickness, the size of the weld fillet or bend radius at the junction of the flange and the casing and the normal washer diameter.

This International Standard accepts that the number and diameter of bolts or screws cannot be established on a theoretical basis. Practical experience of satisfactory service, optimum cost of installation and manufacture as well as dimensional tolerances of production are the most important considerations.

The number of flange holes is divisible by four to permit the orientation of cylindrical cased fans to positions at 90°. The holes are disposed equally each side of the centrelines of the fan. This permits a flange to be divided in half should a split casing be required. It also allows better access to the fixings on the remote side of a fan in a confined installation.

Should an intermediate fan size be required, then the R 40 series shall be used to obtain the nominal inside diameter. The flange details shall be interpreted from the next larger R 20 size.

In exceptional circumstances when even smaller increments of fan size are required, it is suggested that the R 80 series be used.

4.4 Rectangular flange characteristics

The objective of the system is to provide a maximum of freedom of choice of rectangular dimensions, using standardized flange dimensions and standardized locations and sizes of bolt holes throughout the range of fan outlet sizes.

The system is applied by selecting standard bolt hole locations from Table 4 for each of the two dimensions of the fan outlet.

Table 5 and Table 6 show a series of rectangular outlets based on the R 20 series for two alternate methods of determining aspect ratio.

No recommendations are given for the size of angle to be used in the lap-welded design, the choice being determined by the hole offset dimension, g , and the ability to apply a tightening spanner to the nut and bolt specified. For certain aspect ratios other than 1, there are selections where unequal flanges could result from the system (see note 2 of Figure 5). If unequal flanges are undesirable, then equal flange dimensions and bolt sizes may be selected to correspond with the dimensions for the longer of the two sides, but retaining the pitch between the bolt holes to correspond to each outlet side dimension. The offset dimension, g , must remain unaltered to maintain the dimensional integrity of the hole positions.

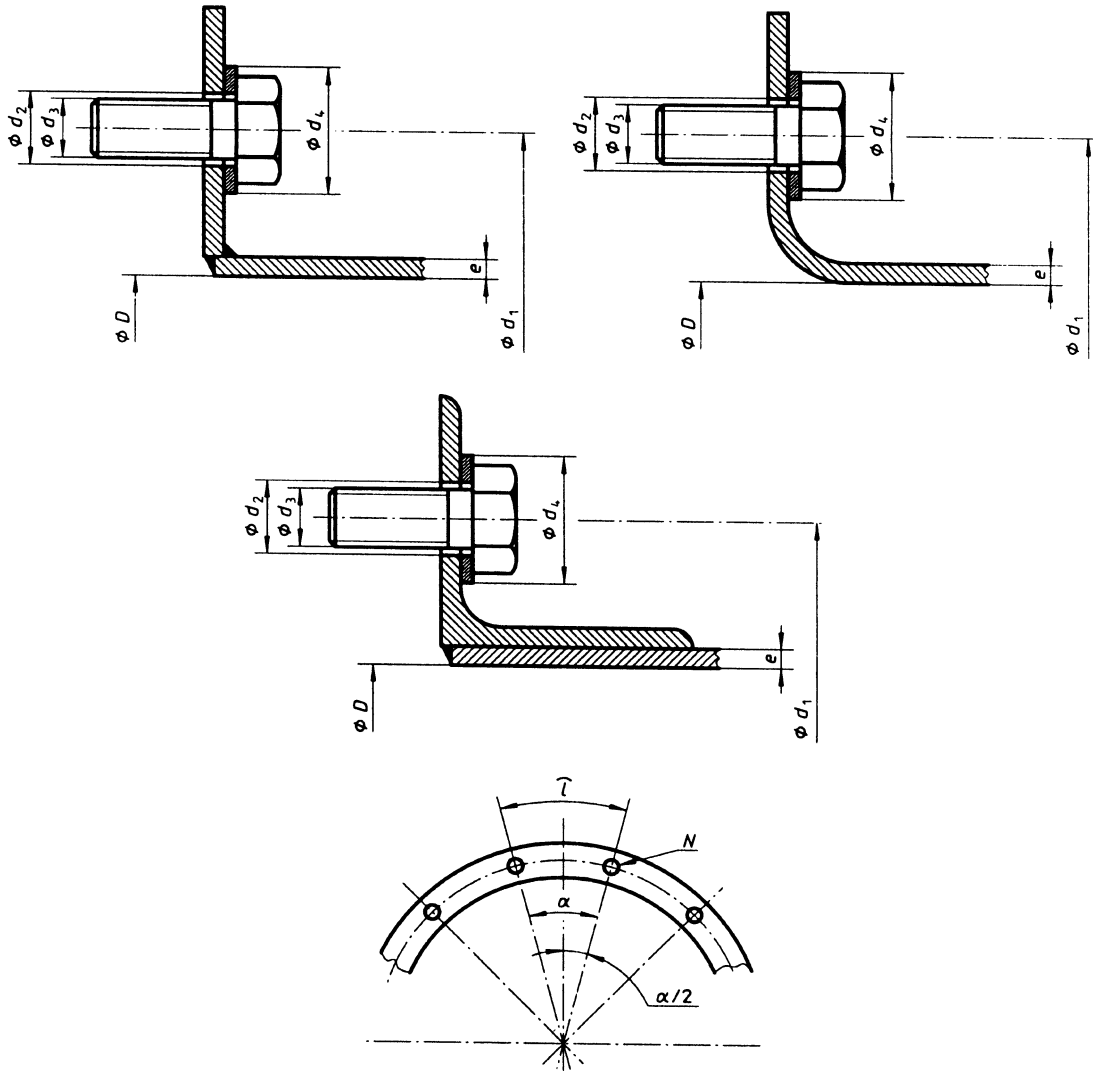

Figure 4 — Circular flanges

Table 2 — Circular flanges — Dimensions for general purpose fans

Dimensions in millimetres

D	d_1	$\frac{d_1 - D}{2}$	Number of holes N	α degrees	l	d_2	d_3	d_4^a	e^a
100	139	19,5	4	90	109	9,5	M8	17	$1,5 \leq e \leq 6$
112	151	19,5	4	90	119	9,5	M8	17	$1,5 \leq e \leq 6$
125	165	20	4	90	130	9,5	M8	17	$1,5 \leq e \leq 6$
140	182	21	8	45	71	11,5	M10	21	$1,5 \leq e \leq 6$
160	200	20	8	45	79	11,5	M10	21	$1,5 \leq e \leq 6$
180	219	19,5	8	45	86	11,5	M10	21	$1,5 \leq e \leq 6$
200	241	20,5	8	45	95	11,5	M10	21	$1,5 \leq e \leq 6$
224	265	20,5	8	45	104	11,5	M10	21	$1,5 \leq e \leq 6$
250	292	21	8	45	115	11,5	M10	21	$1,5 \leq e \leq 6$
280	332	26	8	45	130	11,5	M10	21	$1,5 \leq e \leq 6$
315	366	25,5	8	45	144	11,5	M10	21	$1,5 \leq e \leq 6$
355	405	25	8	45	159	11,5	M10	21	$1,5 \leq e \leq 6$
400	448	24	12	30	117	11,5	M10	21	$1,5 \leq e \leq 6$
450	497	23,5	12	30	130	11,5	M10	21	$1,5 \leq e \leq 6$
500	551	25,5	12	30	144	11,5	M10	21	$1,5 \leq e \leq 6$
560	629	34,5	16	22,5	124	14	M12	24	$2 \leq e \leq 6$
630	698	34	16	22,5	137	14	M12	24	$2 \leq e \leq 6$
710	775	32,5	16	22,5	152	14	M12	24	$2,5 \leq e \leq 6$
800	869	34,5	24	15	113	14	M12	24	$2,5 \leq e \leq 6$
900	958	29	24	15	125	14	M12	24	$3 \leq e \leq 6$
1 000	1 067	33,5	24	15	140	14	M12	24	$3 \leq e \leq 6$
1 120	1 200	40	32	11,25	118	18	M16	30	$4 \leq e \leq 6$
1 250	1 337	43,5	32	11,25	131	18	M16	30	$4 \leq e \leq 6$
1 400	1 475	37,5	32	11,25	145	18	M16	30	$5 \leq e \leq 6$
1 600	1 675	37,5	40	9	132	18	M16	30	$5 \leq e \leq 6$
1 800	1 875	37,5	40	9	147	18	M16	30	6
2 000	2 073	36,5	40	9	163	18	M16	30	6

^a Given for information.

Table 3 — Circular flanges — Dimensions for heavy duty fans

Dimensions in millimetres

D	d_1	$\frac{d_1 - D}{2}$	Number of holes N	α degrees	l	d_2	d_3	d_4^a	e^a
250	325	37,5	12	30	85	14,5	M12	24	$8 \leq e \leq 10$
280	355	37,5	12	30	93	14,5	M12	24	$8 \leq e \leq 10$
315	390	37,5	12	30	102	14,5	M12	24	$8 \leq e \leq 10$
355	430	37,5	16	22,5	84	14,5	M12	24	$8 \leq e \leq 10$
400	475	37,5	16	22,5	93	14,5	M12	24	$8 \leq e \leq 10$
450	525	37,5	20	18	82	14,5	M12	24	$8 \leq e \leq 10$
500	575	37,5	20	18	90	14,5	M12	24	$8 \leq e \leq 10$
560	650	45	20	18	102	18,5	M16	30	$8 \leq e \leq 10$
630	720	45	20	18	113	18,5	M16	30	$8 \leq e \leq 10$
710	800	45	20	18	126	18,5	M16	30	$8 \leq e \leq 10$
800	890	45	24	15	116	18,5	M16	30	$8 \leq e \leq 10$
900	990	45	24	15	130	18,5	M16	30	$8 \leq e \leq 10$
1 000	1 090	55	28	12,85	122	18,5	M16	30	$8 \leq e \leq 10$
1 120	1 230	55	28	12,85	138	24	M20	37	$8 \leq e \leq 10$
1 250	1 360	55	28	12,85	153	24	M20	37	$8 \leq e \leq 10$
1 400	1 510	55	32	11,25	148	24	M20	37	$8 \leq e \leq 10$
1 600	1 710	55	36	10	149	24	M20	37	$8 \leq e \leq 10$
1 800	1 910	55	40	9	150	24	M20	37	$8 \leq e \leq 10$

^a Given for information.

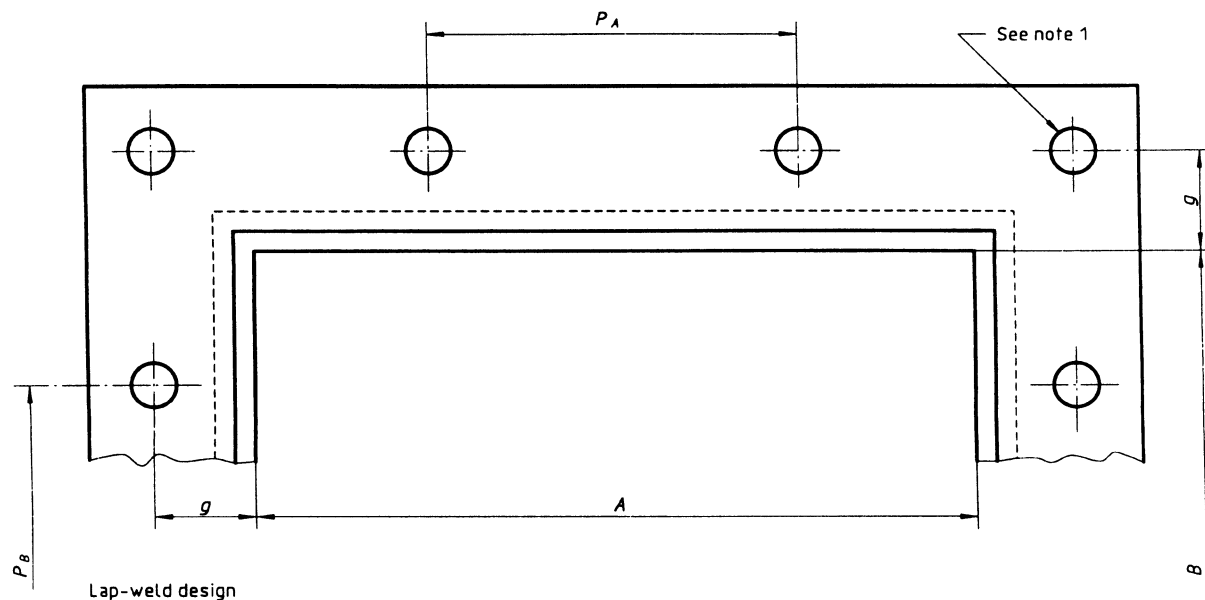

Lap-weld design

Hole locations

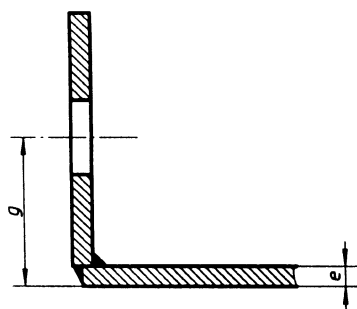

Fabricated flange design

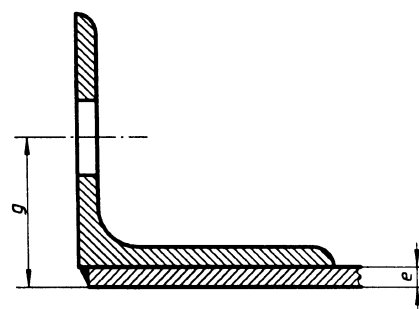

Lap-weld design

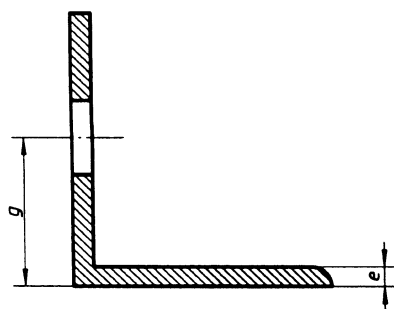

Butt flange design

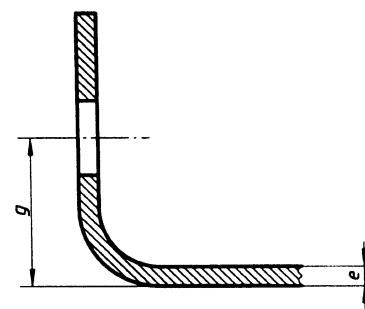

Rolled flange design

Alternative mounting designs

NOTES

- 1 Optional corner holes. Position defined by dimension g .
- 2 For certain aspect ratios other than 1, there are selections where unequal-sized holes would result from the system. If unequal-sized holes are undesirable, then equal hole and bolt sizes may be selected to correspond with the dimensions of the longer of the two sides, but retaining the pitch between the bolt to correspond to each outlet side dimension.

Figure 5 — Rectangular flanges — Dimensions

Table 4 — Rectangular flanges — Dimensions

Dimensions in millimetres

Fan outlet	Pitch	No. of holes per side <i>N</i>		<i>d</i> ₃	<i>d</i> ₂	<i>g</i>	<i>e</i> ^a max.
Inside casing <i>A</i> or <i>B</i>	<i>P</i> _A or <i>P</i> _B	With corner holes	Without corner holes				
100	71	4	2	M6	7	19	2
112	71	4	2	M6	7	19	2
125	71	4	2	M6	7	19	2
140	71	4	2	M6	7	19	2
160	100	4	2	M6	7	19	2
180	100	4	2	M6	7	19	2
200	100	4	2	M6	7	19	2
224	100	4	2	M6	7	19	2
250	125	4	2	M8	10	19	3
280	125	4	2	M8	10	19	3
315	125	5	3	M8	10	19	3
355	125	5	3	M8	10	19	3
400	125	5	3	M8	10	19	3
450	125	6	4	M10	12	32	5
500	125	6	4	M10	12	32	5
560	125	7	5	M10	12	32	5
630	125	7	5	M10	12	32	5
710	125	8	6	M10	12	32	5
800	125	9	7	M10	12	32	5
900	125	9	7	M10	12	32	5
1 000	125	10	8	M12	14	32	5
1 120	125	11	9	M12	14	37	5
1 250	125	12	10	M12	14	37	5
1 400	125	12	10	M12	14	37	5
1 600	125	13	11	M12	14	37	5
1 800	125	15	13	M12	14	37	5
2 000	125	16	14	M12	14	37	5

^a Given for information.

Table 5 — A series of rectangular outlets based on the R 20 series — Aspect ratios, k_p
 [(see footnote 2)]

		Short side mm												
		100	112	125	140	160	180	200	224	250	280	315	355	400 ^a
		k_p^b												
Long side mm	100	1												
	112	0,9	1											
	125	0,8	0,9	1										
	140	0,71	0,8	0,9	1									
	160	0,63	0,71	0,8	0,9	1								
	180	0,56	0,63	0,71	0,8	0,9	1							
	200	0,5	0,56	0,63	0,71	0,8	0,9	1						
	224	0,45	0,5	0,56	0,63	0,71	0,8	0,9	1					
	250	0,4	0,45	0,5	0,56	0,63	0,71	0,8	0,9	1				
	280		0,4	0,45	0,5	0,56	0,63	0,71	0,8	0,9	1			
	315			0,4	0,45	0,5	0,56	0,63	0,71	0,8	0,9	1		
	355				0,4	0,45	0,5	0,56	0,63	0,71	0,8	0,9	1	
	400					0,4	0,45	0,5	0,56	0,63	0,71	0,8	0,9	1
	450	1					0,4	0,45	0,5	0,56	0,63	0,71	0,8	0,9
	500	0,9	1					0,4	0,45	0,5	0,56	0,63	0,71	0,8
	560	0,8	0,9	1					0,4	0,45	0,5	0,56	0,63	0,71
	630	0,71	0,8	0,9	1					0,4	0,45	0,5	0,56	0,63
	710	0,63	0,71	0,8	0,9	1					0,4	0,45	0,5	0,56
	800	0,56	0,63	0,71	0,8	0,9	1					0,4	0,45	0,5
	900	0,5	0,56	0,63	0,71	0,8	0,9	1					0,4	0,45
1 000	0,45	0,5	0,56	0,63	0,71	0,8	0,9	1					0,4	
1 120	0,4	0,45	0,5	0,56	0,63	0,71	0,8	0,9	1					
1 250		0,4	0,45	0,5	0,56	0,63	0,71	0,8	0,9	1				
1 400			0,4	0,45	0,5	0,56	0,63	0,71	0,8	0,9	1			
1 600				0,4	0,45	0,5	0,56	0,63	0,71	0,8	0,9	1		
1 800					0,4	0,45	0,5	0,56	0,63	0,71	0,8	0,9	1	
		k_p^b												
		460	500	560	620	710	800	900	1 000	1 120	1 250	1 400	1 600	1 800
		Short side mm												
NOTE Approximations based on usual "rounded" sizes.														
^a Continued on bottom line.														
^b $k_p = \frac{\text{Short side}}{\text{Long side}}$														

Table 6 — A series of rectangular outlets based on the R 20 series — Aspect ratios, k_g
 [(see footnote 2)]

		Short side mm												
		100	112	125	140	160	180	200	224	250	280	315	355	400 ^a
		k_g^b												
Long side mm	100	1												
	112	1,12	1											
	125	1,25	1,12	1										
	140	1,4	1,25	1,12	1									
	160	1,6	1,4	1,25	1,12	1								
	180	1,8	1,6	1,4	1,25	1,12	1							
	200	2	1,8	1,6	1,4	1,25	1,12	1						
	224	2,24	2	1,8	1,6	1,4	1,25	1,12	1					
	250	2,5	2,24	2	1,8	1,6	1,4	1,25	1,12	1				
	280		2,5	2,24	2	1,8	1,6	1,4	1,25	1,12	1			
	315			2,5	2,24	2	1,8	1,6	1,4	1,25	1,12	1		
	355				2,5	2,24	2	1,8	1,6	1,4	1,25	1,12	1	
	400					2,5	2,24	2	1,8	1,6	1,4	1,25	1,12	1
	450	1					2,5	2,24	2	1,8	1,6	1,4	1,25	1,12
	500	1,12	1					2,5	2,24	2	1,8	1,6	1,4	1,25
	560	1,25	1,12	1					2,5	2,24	2	1,8	1,6	1,4
	630	1,4	1,25	1,12	1					2,5	2,24	2	1,8	1,6
	710	1,6	1,4	1,25	1,12	1					2,5	2,24	2	1,8
	800	1,8	1,6	1,4	1,25	1,12	1					2,5	2,24	2
	900	2	1,8	1,6	1,4	1,25	1,12	1					2,5	2,24
1 000	2,24	2	1,8	1,6	1,4	1,25	1,12	1					2,5	
1 120	2,5	2,24	2	1,8	1,6	1,4	1,25	1,12	1					
1 250		2,5	2,24	2	1,8	1,6	1,4	1,25	1,12	1				
1 400			2,5	2,24	2	1,8	1,6	1,4	1,25	1,12	1			
1 600				2,5	2,24	2	1,8	1,6	1,4	1,25	1,12	1		
1 800					2,5	2,24	2	1,8	1,6	1,4	1,25	1,12	1	
		k_g^b												
		450	500	560	630	710	800	900	1 000	1 120	1 250	1 400	1 600	1 800
		Short side mm												

NOTE Approximations based on usual "rounded" sizes.

^a Continued on bottom line.

^b $k_g = \frac{\text{Long side}}{\text{Short side}}$

List of references

See national foreword.

BSI — British Standards Institution

BSI is the independent national body responsible for preparing British Standards. It presents the UK view on standards in Europe and at the international level. It is incorporated by Royal Charter.

Revisions

British Standards are updated by amendment or revision. Users of British Standards should make sure that they possess the latest amendments or editions.

It is the constant aim of BSI to improve the quality of our products and services. We would be grateful if anyone finding an inaccuracy or ambiguity while using this British Standard would inform the Secretary of the technical committee responsible, the identity of which can be found on the inside front cover. Tel: 020 8996 9000. Fax: 020 8996 7400.

BSI offers members an individual updating service called PLUS which ensures that subscribers automatically receive the latest editions of standards.

Buying standards

Orders for all BSI, international and foreign standards publications should be addressed to Customer Services. Tel: 020 8996 9001. Fax: 020 8996 7001.

In response to orders for international standards, it is BSI policy to supply the BSI implementation of those that have been published as British Standards, unless otherwise requested.

Information on standards

BSI provides a wide range of information on national, European and international standards through its Library and its Technical Help to Exporters Service. Various BSI electronic information services are also available which give details on all its products and services. Contact the Information Centre. Tel: 020 8996 7111. Fax: 020 8996 7048.

Subscribing members of BSI are kept up to date with standards developments and receive substantial discounts on the purchase price of standards. For details of these and other benefits contact Membership Administration. Tel: 020 8996 7002. Fax: 020 8996 7001.

Copyright

Copyright subsists in all BSI publications. BSI also holds the copyright, in the UK, of the publications of the international standardization bodies. Except as permitted under the Copyright, Designs and Patents Act 1988 no extract may be reproduced, stored in a retrieval system or transmitted in any form or by any means – electronic, photocopying, recording or otherwise – without prior written permission from BSI.

This does not preclude the free use, in the course of implementing the standard, of necessary details such as symbols, and size, type or grade designations. If these details are to be used for any other purpose than implementation then the prior written permission of BSI must be obtained.

If permission is granted, the terms may include royalty payments or a licensing agreement. Details and advice can be obtained from the Copyright Manager. Tel: 020 8996 7070.