

# Fans for general purposes —

## Part 7: Specifications for balancing and vibration

ICS 21.120.40; 23.120

## National foreword

This British Standard reproduces verbatim ISO 14694:2003 and implements it as the UK national standard.

The UK participation in its preparation was entrusted to Technical Committee MCE/17, Industrial fans, which has the responsibility to:

- aid enquirers to understand the text;
- present to the responsible international/European committee any enquiries on the interpretation, or proposals for change, and keep the UK interests informed;
- monitor related international and European developments and promulgate them in the UK.

A list of organizations represented on this committee can be obtained on request to its secretary.

### Cross-references

The British Standards which implement international publications referred to in this document may be found in the *BSI Catalogue* under the section entitled “International Standards Correspondence Index”, or by using the “Search” facility of the *BSI Electronic Catalogue* or of British Standards Online.

This publication does not purport to include all the necessary provisions of a contract. Users are responsible for its correct application.

**Compliance with a British Standard does not of itself confer immunity from legal obligations.**

### Summary of pages

This document comprises a front cover, an inside front cover, the ISO title page, pages ii to v, a blank page, pages 1 to 39 and a back cover.

The BSI copyright date displayed in this document indicates when the document was last issued.

### Amendments issued since publication

Amd. No.	Date	Comments

This British Standard was published under the authority of the Standards Policy and Strategy Committee on 14 May 2003

© BSI 14 May 2003

ISBN 0 580 41702 6

INTERNATIONAL  
STANDARD

**ISO**  
**14694**

First edition  
2003-03-15

---

---

**Industrial fans — Specifications for  
balance quality and vibration levels**

*Ventilateurs industriels — Spécifications pour l'équilibrage et les  
niveaux de vibration*



Reference number  
ISO 14694:2003(E)



# Contents

Page

Foreword .....	iv
Introduction .....	v
1 Scope .....	1
2 Normative references .....	2
3 Terms and definitions .....	2
4 Symbols and units .....	7
5 Purpose of the test .....	8
6 Balance and vibration application categories (BV categories) .....	9
7 Balancing .....	10
7.1 General .....	10
7.2 Balance quality grade .....	10
7.3 Calculation of permissible residual unbalance .....	10
8 Fan vibration .....	11
8.1 Measurement requirements .....	11
8.2 Fan support system .....	15
8.3 Fan vibration limits for tests in manufacturer's work-shop .....	15
8.4 Fan vibration limits for operation <i>in situ</i> .....	15
9 Other rotating components .....	16
10 Instruments and calibration .....	17
10.1 Instruments .....	17
10.2 Calibration .....	17
11 Documentation .....	17
11.1 Balance .....	17
11.2 Fan vibration .....	17
11.3 Certificates .....	18
Annex A (informative) Relationship of vibration displacement, velocity and acceleration for sinusoidal motion .....	20
Annex B (informative) Assembly practices for balancing in a balancing machine .....	22
Annex C (informative) Sources of vibrations .....	24
Annex D (informative) Equation of vibration .....	30
Annex E (informative) Vibration and supports .....	32
Annex F (informative) Out of balance and bearing reactions .....	33
Annex G (informative) Condition monitoring and diagnostic guidelines .....	36
Annex H (informative) Suggested relaxation of specified grades and levels .....	37
Bibliography .....	38

## Foreword

ISO (the International Organization for Standardization) is a worldwide federation of national standards bodies (ISO member bodies). The work of preparing International Standards is normally carried out through ISO technical committees. Each member body interested in a subject for which a technical committee has been established has the right to be represented on that committee. International organizations, governmental and non-governmental, in liaison with ISO, also take part in the work. ISO collaborates closely with the International Electrotechnical Commission (IEC) on all matters of electrotechnical standardization.

International Standards are drafted in accordance with the rules given in the ISO/IEC Directives, Part 2.

The main task of technical committees is to prepare International Standards. Draft International Standards adopted by the technical committees are circulated to the member bodies for voting. Publication as an International Standard requires approval by at least 75 % of the member bodies casting a vote.

Attention is drawn to the possibility that some of the elements of this document may be the subject of patent rights. ISO shall not be held responsible for identifying any or all such patent rights.

ISO 14694 was prepared by Technical Committee ISO/TC 117, *Industrial fans*.

## Introduction

ISO 14694 is a part of a series of standards covering important aspects of fans which affect their design, manufacture and use. This series includes ISO 5801, ISO 5802, ISO 12499, ISO 13347, ISO 13348, ISO 13349, ISO 13350, ISO 13351, ISO 14695 and CEN/BTS 2/AH 17.

This International Standard addresses the needs of both users and manufacturers of fan equipment for a technically accurate but uncomplicated set of information on the subjects of balance precision and vibration levels.

Vibration is recognized as an important parameter in the description of the performance of fans. It gives an indication of how well the fan has been designed and constructed and can forewarn of possible operational problems. These problems may be associated with inadequacies of support structures and machine deterioration, etc.

Although alternative standards exist which deal with vibration of machines generally (e.g. ISO 10816), they currently have limitations because of their universal nature, when considering a specific family of machines such as fans, with installed powers below 300 kW.

Vibration measurements may therefore be required for a variety of reasons of which the following are the most important:

- a) design/development evaluations;
- b) in situ testing;
- c) as information for a condition-monitoring or machinery health programme (ISO 14695:2003, Annex C gives recommended measuring positions for machinery health measurement);
- d) to inform the designer of supporting structures, foundations, ducting systems, etc., of the residual vibration which will be transmitted by the fan into the structure;
- e) as a quality assessment at the final inspection stage.

**NOTE** All the information which can be obtained from tests conducted in accordance with this International Standard (see Clause 10 of ISO 14695:2003) is neither necessary nor appropriate for quality-grading purposes.

Whilst an open inlet/open outlet test may be useful as a quality guide, this International Standard recognizes that the vibration of a fan will be dependent upon the aerodynamic duty specified, which determines the rotational speed and position on the fan.

This International Standard should be read in conjunction with ISO 10816-1, ISO 10816-3 and ISO 14695 which describe the methods to be used and the positions of the transducers. When information is required on vibration transmitted to ducting connections or foundations, then this is especially important. The gradings included are such as are generally recommended for commercially available fans.

It is important to remember that vibration testing can be extremely expensive, sometimes considerably in excess of the fan's initial cost. Only when the functioning of the installation may be affected should discrete frequency or band limitations be imposed. The number of test points should also be limited according to the usage envisaged. Readings at the fan bearings are of most importance and for normal quality gradings should be sufficient.





# Industrial fans — Specifications for balance quality and vibration levels

## 1 Scope

This International Standard gives specifications for vibration and balance limits of fans for all applications except those designed solely for air circulation, for example, ceiling fans and table fans. However, it is limited to fans of all types installed with a power of less than 300 kW or to a commercially available standard electric motor with a maximum power of 355 kW (following an R20 series). For fans of greater power than this, the applicable limits are those given in ISO 10816-3. Where the fans in an installation have varying powers both above and below 300 kW, and have been the subject of a single contract, then the manufacturer and purchaser shall agree on the appropriate standard to be used. This should normally be based on the majority of units.

Vibration data may be required for a variety of purposes as detailed in Clause 5.

The International Standard recognizes that vibrational measurements may be recorded as velocity, acceleration or displacement either in absolute units or in decibels above a given reference level. The magnitude of vibration measurements may be affected by assembly practices at balancing machines (see Annex B). The preferred parameter is, however, the velocity, in millimeters per second (mm/s). As the conventions vary in different parts of the world, both r.m.s. (root mean square) and peak-to-peak or peak values are given. It should also be remembered that a fan and its parts may be considered as a spring-mass system. An understanding of this fact helps to resolve most vibrational problems (see Annex D).

Account has also been taken of the fact that factory tests are usually conducted with the fan unconnected to a ducting system, such that its aerodynamic duty may be considerably different from that during normal operation. It may also be supported on temporary foundations of different mass and stiffness to those used in situ. Accordingly, such tests are specified with vibration measured “filter-in”. In situ tests are specified “filter-out” and as such represent a measure of overall vibration severity.

This International Standard covers fan equipment with rigid rotors, generally found in: commercial heating, ventilating and air conditioning, industrial processes, mine/tunnel ventilation and power-generation applications. Other applications are not specifically excluded. Excluded are installations which involve severe forces, impacts or extreme temperatures. Any or all portions of this International Standard, or modifications thereof, are subject to agreement between the parties concerned.

Fan-equipment foundations and installation practices are beyond the scope of this International Standard. Foundation design and fan installation are not normally the responsibilities of the fan manufacturer. It is fully expected that the foundations upon which the fan is mounted will provide the support and stability necessary to meet the vibration criteria of the fan as it is delivered from the factory.

Other factors, such as impeller cleanliness, aerodynamic conditions, background vibration, operation at speeds other than those agreed upon, and maintenance of the fan, affect the fan-vibration levels but are beyond the scope of this International Standard.

This International Standard is intended to cover only the balance or vibration of the fan and does not take into account the effect of fan vibration on personnel, equipment or processes.

## 2 Normative references

The following referenced documents are indispensable for the application of this document. For dated references, only the edition cited applies. For undated references, the latest edition of the referenced document (including any amendments) applies.

ISO 254, *Belt drives — Pulleys — Quality, finish and balance*

ISO 1940-1:1986, *Mechanical vibration — Balance quality requirements of rigid rotors — Part 1: Determination of permissible residual unbalance*

ISO 1940-1:—<sup>1</sup>), *Mechanical vibration — Balance quality requirements of rigid rotors — Part 1: Specification and verification of balance tolerances*

ISO 4863:1984, *Resilient shaft couplings — Information to be supplied by users and manufacturers*

ISO 5348:1998, *Mechanical vibration and shock — Mechanical mounting of accelerometers*

ISO 5801:1997, *Industrial Fans — Performance testing using standardized airways*

ISO 7919-1, *Mechanical vibration of non-reciprocating machines — Measurements on rotating shafts and evaluation criteria — Part 1: General guidelines*

ISO 10816-3:1998, *Mechanical vibration — Evaluation of machine vibration by measurements on non-rotating parts — Part 3: Industrial machines with nominal power above 15 kW and nominal speeds between 120 r/min and 15 000 r/min when measured in situ*

ISO 13348:—<sup>2</sup>), *Industrial fans — Specification of technical data and verification of performance*

ISO 14695:2003, *Industrial fans — Method of measurement of fan vibration*

## 3 Terms and definitions

For the purposes of this document, the following terms and definitions apply.

**3.1 vibration severity**  
generic term that designates a value, or set of values, such as a maximum value, average or r.m.s. value, or other parameter that is descriptive of the vibration

NOTE 1 The vibration severity may refer to instantaneous values or to average values.

NOTE 2 Adapted from ISO 2041:1990, definition 2.42.

**3.2 axis of rotation**  
instantaneous line about which a body rotates

NOTE 1 If the bearing are anisotropic, there is no stationary axis of rotation.

NOTE 2 In the case of rigid bearings, the axis of rotation is the shaft axis, but if the bearings are not rigid, this axis of rotation is not necessarily the shaft axis.

NOTE 3 Adapted from ISO 1925:2001, definition 1.4.

---

1) To be published. (Revision of ISO 1940-1:1986)

2) To be published.

**3.3****balancing**

procedure by which the mass distribution of a rotor is checked and, if necessary, adjusted to ensure that the residual unbalance or the vibration of the journals and/or forces on the bearings at a frequency corresponding to service speed are within specified limits

NOTE 1 Balancing of fan impellers is achieved by the process of adding (or removing) weight in a plane or planes on the impeller in order to move the centre of gravity towards the axis of rotation. This will reduce the unbalance forces.

NOTE 2 Adapted from ISO 1925:2001, definition 4.1.

**3.4****balance quality grade**

(rigid rotors) measure for classification which is the product of the specific unbalance and the maximum service angular velocity of the rotor, expressed in millimetres per second

NOTE 1 Commonly used grades in ISO 1940-1 refer to the vibration that would result if that rotor operated in free space i.e. balance grade 6,3 corresponds to a shaft vibration of 6,3 mm/s, peak velocity, at the operating speed of the rotor.

NOTE 2 Adapted from ISO 1925:2001, definition 3.16.

**3.5****displacement****relative displacement**

vector quantity that specifies the change of position of a body, or particle, with respect to a reference frame

NOTE 1 The reference frame is usually a set of axes at a mean position or a position of rest. In general, the velocity can be represented by a rotation vector, a translation vector, or both.

NOTE 2 A displacement is designated as relative displacement if it is measured with respect to a reference frame other than the primary reference frame designated in the given case. The relative displacement between two points is the vector difference between the displacements of the two points.

NOTE 3 Adapted from ISO 2041:1990, definition 1.1.

**3.6****displacement measurements**

vibration values that describe the motion of the rotating-shaft surface relative to the static bearing housing

See ISO 7919-1.

**3.7****electrical runout**

certain errors which may be introduced into runout measurements when using non-contacting sensors

NOTE 1 Such errors may arise from residual magnetism or electrical inhomogeneity in the measured component or other effects which affect the calibration of the sensor.

NOTE 2 This total measured variation in the apparent location of a ferrous-shaft surface during a complete slow rotation is determined by an eddy-current probe system. This measurement may be affected by variations in the electrical/magnetic properties of the shaft material as well as variations in the shaft surface itself.

NOTE 3 Adapted from ISO 1925:2001, definition 2.19.

**3.8****fan application category**

descriptive grouping used to describe fan applications, their appropriate Balance Quality Grades and Recommended Vibration Levels

**3.9**  
**fan vibration level**

vibration amplitude at the fan bearings expressed in units of velocity or displacement

**3.10**  
**filter**

device for separating oscillations on the basis of their frequency

NOTE 1 It introduces relatively small attenuation to wave oscillations in one or more frequency bands and relatively large attenuation to oscillations of other frequencies.

NOTE 2 Adapted from ISO 2041:1990, definition B.14.

**3.11**  
**filter-in**  
**sharp**

vibration measured only at a frequency of interest

**3.12**  
**filter-out**  
**broad pass**

vibration measured in a wide frequency range

NOTE This is sometimes called "overall" vibration.

**3.13**  
**flexible support**

fan support system designed so that the first natural frequency of the support is well below the operating speed of the fan

NOTE Often this involves compliant elastic elements between the fan and the supporting structure. This condition is achieved by suspending the machine on a spring or by mounting on an elastic support (springs, rubber, etc.). The natural oscillation frequency of the suspension and machine is typically less than 25 % of the frequency corresponding to the lowest speed of the machine under test.

**3.14**  
**foundation**

structure that supports a mechanical system

NOTE 1 It may be fixed in a specified reference frame or it may undergo a motion that provides excitation for the supported system.

NOTE 2 For fans, these are the components on which the fan is mounted and which provide the necessary support. Fan foundations must have sufficient mass and rigidity to avoid vibration amplification.

NOTE 3 Adapted from ISO 2041:1990, definition 1.23.

**3.15**  
**frequency**  
**cyclic frequency**

the reciprocal of the fundamental period

NOTE 1 The unit of frequency is the Hertz (Hz) which corresponds to one cycle per second.

NOTE 2 In the fan industry, it is also common to use the number of cycles occurring per minute (CPM).

NOTE 3 Adapted from ISO 2041:1990, definition 2.24.

**3.16**  
**in situ**

refers to operation at the final installation site

**3.17****mechanical run-out**

total actual variation in the location of a shaft surface during a complete slow rotation as determined by a stationary measuring device (such as a dial indicator)

**3.18****journal**

that part of a rotor which is supported radially and/or guided by a bearing in which it rotates

NOTE Adapted from ISO 1925:2001, definition 2.4.

**3.19****overall fan vibration**

See definition 3.12

**3.20****peak value****peak magnitude****positive (negative) peak value**

maximum value of a vibration during a given interval

NOTE 1 A peak-value vibration is usually taken as the maximum deviation of that vibration from the mean value. A positive peak value is the maximum positive deviation and a negative peak value is the maximum negative deviation.

NOTE 2 Peak displacement, velocity or acceleration readings refer to the value occurring at the maximum deviation from zero or the stationary value (see Annex A).

NOTE 3 Adapted from ISO 2041:1990, definition 2.34.

**3.21****peak-to-peak value (of a vibration)**

⟨vibration⟩ algebraic difference between the extreme values of the vibration

NOTE 1 In industrial practice, peak-to-peak amplitudes refer to the total range travelled in one cycle. Peak-to-peak readings apply to displacements only (see Annex A).

NOTE 2 Adapted from ISO 2041:1990, definition 2.35.

**3.22****root-mean-square value****r.m.s. value**

⟨set of numbers⟩ square root of the average of their squared values

NOTE 1 The r.m.s. value of a set of numbers can be represented as follows:

$$\text{r.m.s. value} = \left( \frac{\sum x_n^2}{N} \right)^{1/2}$$

where the subscript  $n$  refers to the  $n^{\text{th}}$  number, of which there are a total of  $N$ .

⟨single-valued function,  $f(t)$ , over an interval between  $t_1$  and  $t_2$ ⟩ square root of the average of the squared values of the function over the interval

NOTE 2 The r.m.s. value of a single-valued function,  $f(t)$ , over an interval between equal to  $t_1$  and  $t_2$  is equal to

$$\text{r.m.s. value} = \left( \frac{\int_{t_1}^{t_2} f(t)^2 dt}{t_2 - t_1} \right)^{1/2}$$

NOTE 3 In vibration theory, the mean value of the vibration is equal to zero. In this case, the r.m.s. value is equal to the standard deviation, and the mean-square value is equal to the variance ( $\sigma^2$ ).

NOTE 4 For true sinusoidal motion the r.m.s. value is equal to 0,707 times the peak value.

NOTE 5 Adapted from ISO 2041:1990, definition A.37.

### 3.23 residual unbalance

#### final unbalance

unbalance of any kind that remains after balancing

NOTE Adapted from ISO 1925:2001, definition 3.10.

### 3.24 rigid support

fan support system designed so that the first natural frequency of the system is well above the operating speed of the fan

NOTE The rigidity of a foundation is a relative quantity. It must be considered in conjunction with the rigidity of the machine-bearing system. The ratio of bearing-housing vibration to foundation vibration is a characteristic quantity for the evaluation of foundation flexibility influences. A foundation may be rigid and of sufficient mass if the vibration amplitude of the foundation (in any direction) near the machine's feet or base frame is less than 25 % of the maximum amplitude that is measured at the adjacent bearing housing in any direction.

### 3.25 speed, design

maximum rotational speed, measured in revolutions per minute (r/min), for which the fan is designed to operate

### 3.26 speed, service

rotational speed, measured in revolutions per minute (r/min), for which a rotor operates in its final installation or environment

### 3.27 triaxial set

orientations of the vibration transducer for vibration-amplitude measurements

NOTE A triaxial set refers to a set of three readings taken in three mutually perpendicular (normally horizontal, vertical and axial) directions.

### 3.28 trim balancing

correction of small residual unbalances in a rotor, often *in situ*

NOTE 1 The balance process may make minor correction in unbalance which become necessary as a result of the fan assembly and/or installation process.

NOTE 2 Adapted from ISO 1925:2001, definition 4.27.

### 3.29 unbalance

condition which exists in a rotor when vibration force or motion is imparted to its bearings as a result of centrifugal forces

NOTE 1 The term unbalance is sometimes used as a synonym for amount of unbalance, or unbalance vector.

NOTE 2 The term imbalance is sometimes used in place of unbalance, but this is deprecated.

NOTE 3 Unbalance is usually measured by the product of the mass of the rotor times the distance between its centre of gravity and its centre of rotation in a plane. In general practice unbalance values are reported as

- peak-to-peak displacement, in micrometres ( $\mu\text{m}$ ) or millimetres (mm);
- velocity — r.m.s. or peak, in millimetres per second (mm/s);
- acceleration — r.m.s. or peak, in metres per second squared ( $\text{m/s}^2$ ).

NOTE 4 Adapted from ISO 1925:2001, definition 3.1.

### 3.30

#### velocity

#### relative velocity

vector that specifies the time-derivative of displacement

NOTE 1 The reference frame is usually a set of axes at a mean position or a position of rest. In general, the velocity can be represented by a rotation vector, a translation vector, or both.

NOTE 2 A velocity is designated as relative velocity if it is measured with respect to a reference frame other than the primary reference frame designated in a given case. The relative velocity between two points is the vector difference between the velocities of the two points.

NOTE 3 Adapted from ISO 2041:1990, definition 1.2.

### 3.31

#### vibration

variation with time of the magnitude of a quantity which is descriptive of the motion or position of a mechanical system, when the magnitude is alternately greater and smaller than some average value or reference

NOTE 1 Vibration may be thought of as the alternating mechanical motion of an elastic system, components of which are amplitude, frequency and phase. In general practice, vibration values are reported as:

- peak-to-peak displacement, in micrometres ( $\mu\text{m}$ ) or millimetres (mm);
- velocity — r.m.s. or peak, in millimetres per second (mm/s);
- acceleration — r.m.s. or peak, in metres per second squared ( $\text{m/s}^2$ ).

NOTE 2 Adapted from ISO 2041:1990, definition 2.1.

### 3.32

#### vibration spectrum

description of the vibration in terms of the amplitudes of its components versus frequency

### 3.33

#### vibration transducer

device designed to be attached to a mechanical system for measurement of vibration

NOTE It converts the vibratory energy into a proportional electronic signal that can be displayed or otherwise processed.

## 4 Symbols and units

For the purposes of this International Standard, the following symbols and units shall be used.

Symbol	Description	Unit
$a$	Instantaneous vibration acceleration	$\text{m/s}^2$
$a_0$	Reference vibration acceleration	$\text{m/s}^2$
$A_{\text{peak}}$	Vibration acceleration amplitude of peak	$\text{m/s}^2$ or $g$ (1 $g = 9,806\ 65\ \text{m/s}^2$ )
$A_{\text{r.m.s.}}$	r.m.s. vibration acceleration amplitude	$\text{m/s}^2$ or $g$ (1 $g = 9,806\ 65\ \text{m/s}^2$ )
$A_{\text{dB}}$	r.m.s. vibration acceleration level above a reference of $10^{-6}\ \text{m/s}^2$	dB
	$A_{\text{dB}} = 20 \log_{10} \left( \frac{A_{\text{r.m.s.}}}{10^{-6}} \right)$	
$d$	Instantaneous vibration displacement	$\mu\text{m}$ , mm or m
$D$	Peak-to-peak vibration-displacement amplitude	$\mu\text{m}$ or mm
$D_{\text{r.m.s.}}$	r.m.s. vibration-displacement amplitude	$\mu\text{m}$ or mm
$e_{\text{per}}$	Specific unbalance	$\mu\text{m}$ or g-mm/kg
$f$	Frequency = $\omega/2\pi$	Hz
$G$	Balance quality grade	—
$m$	Rotor mass	kg
$n$	Rotational frequency	r/s
$N$	Rotational frequency (rotor service speed)	r/min
$t$	Time	s
$T$	Period of vibration	s
$U_{\text{per}}$	Permissible residual unbalance (moment)	g-mm
$v$	Instantaneous vibration velocity	$\mu\text{m/s}$ or mm/s or m/s
$V_0$	Reference vibration velocity	$\mu\text{m/s}$ , mm/s or m/s
$V_{\text{peak}}$	Vibration velocity of peak	$\mu\text{m/s}$ , mm/s or m/s
$V_{\text{r.m.s.}}$	Overall root-mean-square velocity	mm/s or m/s
$V_{\text{dB}}$	r.m.s. vibration velocity above a reference level of $10^{-9}\ \text{m/s}$	dB
	$V_{\text{dB}} = 20 \log_{10} \left( \frac{V_{\text{r.m.s.}}}{10^{-9}} \right)$	
$\omega$	Angular velocity of impeller	$\text{rad}\cdot\text{s}^{-1}$

## 5 Purpose of the test

Before carrying out any vibration test, the purpose for which information is required should be clearly defined and agreed between the parties concerned.

The most important reasons for carrying out a vibration test are as follows:

- a) design/development evaluations (see Annex D);



- b) as a quality assessment at the final inspection stage (see 8.3 and Annex D);
- c) *in situ* testing for comparison with factory measurement to determine support/ductwork connection adequacy (see Annex E);
- d) as baseline and trend information for a condition-monitoring or machinery health programme (see Annex G);
- e) to inform the designer of associated supporting structures, foundations, ducting systems, etc. of the residual vibration which will be transmitted by the fan into the associated structure.

Readings may be recorded as overall linear response levels, in octave bands, in 1/3 octave bands, or as a narrow band (discrete) analysis. The amount of information to be presented is dependent on the category of fan, as defined in Clause 6, and the purposes for which the information is to be used.

## 6 Balance and vibration application categories (BV categories)

The design/structure of a fan and its intended application are important criteria for categorizing the many types of fans in terms of applicable and meaningful balance grades and vibration levels.

Table 1 has been compiled to provide categories into which fans may be placed for the purpose of classifying the type of application with respect to acceptable balance and vibration limits.

**Table 1 — Fan-application categories**

Application	Examples	Limits of driver power kW	Fan-application category, BV
Residential	Ceiling fans, attic fans, window AC	≤ 0,15	BV-1
		> 0,15	BV-2
HVAC and agricultural	Building ventilation and air conditioning; commercial systems	≤ 3,7	BV-2
		> 3,7	BV-3
Industrial process and power generation, etc.	Baghouse, scrubber, mine, conveying, boilers, combustion air, pollution control, wind tunnels	≤ 300	BV-3
		> 300	See ISO 10816-3
Transportation and marine	Locomotive, trucks, automobiles	≤ 15	BV-3
		> 15	BV-4
Transit/tunnel	Subway emergency ventilation, tunnel fans, garage ventilation, Tunnel Jet Fans	≤ 75	BV-3
		> 75	BV-4
		none	BV-4
Petrochemical process	Hazardous gases, process fans	≤ 37	BV-3
		> 37	BV-4
Computer-chip manufacture	Clean rooms	none	BV-5

NOTE 1 This standard is limited to fans below approximately 300 kW. For fans above this power refer to ISO 10816-3. However, a commercially available standard electric motor may be rated at up to 355 kW (following an R20 series as specified in ISO 10816-1). Such fans will be accepted in accordance with this International Standard.

NOTE 2 This Table does not apply to the large diameter (typically 2 800 mm to 12 500 mm diameter) lightweight low-speed axial flow fans used in air-cooled heat exchangers, cooling towers, etc. The balance quality requirements for these fans shall be G 16 and the fan-application category shall be BV-3.

The fan manufacturer will typically identify the appropriate fan-application category based on the type of equipment and power requirement. The purchaser of a fan impeller or rotor may be interested only in the balance grade (see Table 2). The purchaser of a complete fan assembly may be interested in one or more of the following: the balance grade (Table 2), vibration in the factory (Table 4), vibration *in situ* (Table 5). Typically, one BV category will apply to all the considerations. However, a purchaser may request a BV category different from the one listed for the application, noting that this may affect the contract price. In most cases, the BV category, the balance quality grade and all acceptable vibration limits must be agreed upon as part of the contract for the fan equipment. In the event that no such agreement can be reached, or is not a part of the contract, then fans purchased according to this International Standard shall meet the vibration limits given in Table 4 (assembled fans) or the residual unbalance requirements in Table 2 (disassembled fans).

The purchaser may contract for a particular mounting arrangement to be used for factory testing of an assembled fan in order to match the planned *in situ* mounting. If no pre-arrangement exists, the fan may be mounted either rigidly or flexibly for the test, regardless of the planned *in situ* mounting.

## 7 Balancing

### 7.1 General

The fan manufacturer is responsible for balancing the fan-impeller assembly to acceptable commercial standards. This International Standard is based on ISO 1940-1. Balancing is generally performed on highly sensitive purpose-built, balancing machines which permit accurate assessment of residual unbalance.

### 7.2 Balance quality grade

The following balance quality grades apply to fan impellers. A fan manufacturer may include other rotating components (shaft, coupling, sheave/pulley, etc.) in the rotating assembly being balanced. In addition, balance of individual components may be required. See references ISO 4863 and ISO 254 for balance requirements for couplings and pulleys.

Table 2 — Balance quality grades

Fan-application category	Balance quality grade for rigid rotors/impeller
BV-1	G 16
BV-2	G 16
BV-3	G 6,3
BV-4	G 2,5
BV-5	G 1,0

NOTE In fan application category BV-1, there may be some extremely small fan rotors weighing less than 224 g. In such cases, residual unbalance may be difficult to determine accurately. The fabrication process should ensure reasonably equal weight distribution about the axis of rotation.

### 7.3 Calculation of permissible residual unbalance

G grades as given in Table 1 are balance quality grades and are derived from the product of the relationship  $e_{\text{per}} \times \omega$ , in millimetres per second, where  $e_{\text{per}}$  is the permissible residual unbalance, and  $\omega$  is the angular velocity of the impeller.

Thus,

- specific unbalance, in micrometres ( $\mu\text{m}$ ) or in grams millimetres per kilogram ( $\text{g}\cdot\text{mm}/\text{kg}$ );

$$e_{\text{per}} = \frac{G}{\omega} \times 10^3$$

- permissible residual unbalance (moment), in grams millimetres ( $\text{g}\cdot\text{mm}$ );

$$U_{\text{per}} = m \times e_{\text{per}}$$

- angular velocity of impeller, in radians per second ( $\text{rad}/\text{s}$ );

$$\omega = 2\pi \times N/60$$

In most applications, the permissible residual unbalance in each of two correction planes can be set at  $U_{\text{per}}/2$  (see Annex F). Whenever possible, the fan impeller should be mounted on the shaft that will be used in operation. If a mandrel is used, care should be taken to avoid eccentricity due to a loose hub-to-mandrel fit (see Annex B).

Calculation of residual unbalance shall comply with 6.2.3 of ISO 1940-1:—, and measurement shall comply with Clause 8.

## 8 Fan vibration

### 8.1 Measurement requirements

#### 8.1.1 General

Figures 1 to 4 illustrate some of the possible locations and directions for taking vibration readings on each fan bearing. Other positions may be relevant for the measurement of vibration at foundations or fan flanges (see ISO 14695). The values shown in Table 4 are based on readings taken perpendicular to the axis of rotation. The number and location of the readings to be taken during shop or *in situ* operation is at the discretion of the fan manufacturer or by agreement with the purchaser. It is recommended that measurements be taken on the impeller shaft bearings. When this is not possible, the pickup shall be mounted in the shortest direct mechanical path between the transducer and the bearing. Transducers shall not be mounted on unsupported panels, the fan housing, guards, flanges or elsewhere on the fan when a continuous mechanical path cannot be obtained, unless required for giving information on vibration transmitted to ducting and/or foundations (see ISO 14695 and ISO 5348).

Horizontal readings shall always be taken in a radial direction at right angles to the fan shaft. Vertical readings shall always be taken at a right angle relative to the fan shaft and at right angles from the horizontal reading. Axial readings shall always be taken parallel to the shaft (rotor) axis.

#### 8.1.2 Seismic readings

All vibration values in this International Standard are seismic readings which represent the motion of the bearing housing.

Observations to be taken shall include readings taken with accelerometer or velocity-type instruments. Particular attention should be given to ensure that the vibration-sensing transducer is correctly mounted without looseness, rocking, or resonance. The size and weight of the transducer and its mounting system should not be so large that its presence affects the vibration-response characteristics of the fan significantly. Variables associated with transducer mounting and variations in instrument calibration can lead to variations in measurements of  $\pm 10\%$  of the values given herein.

### 8.1.3 Displacement readings

The user and manufacturer may agree to measure shaft displacement within the sleeve-bearing oil film by means of proximity probe systems.

Such systems measure the relative motion between the rotating shaft surface and the static bearing housing. Clearly, the allowable displacement amplitude must be limited to a value less than the diametral clearance of the bearing. This internal clearance varies as a function of the bearing size, the radial/axial loading, the bearing type, and the axis of interest (i.e., some designs have an elliptical bore with larger clearance in the horizontal axis than the vertical axis). Therefore it is not the intent of this International Standard to establish discrete shaft-displacement limits for all sleeve bearings and fan applications. However, the following guideline is recommended for shaft-displacement limits. The values shown in Table 3 are the percentage of the total available clearance within the bearing in each axis.

**Table 3 — Percentage of total available clearance within the bearing in each axis**

Condition	Maximum recommended displacement as a percentage of available diametral clearance (any axis)
<b>Start-up/ Satisfactory</b>	less than + 25 % NOTE Contact the bearing supplier to obtain the available diametral and axial clearances within the particular sleeve bearing being used.
<b>Alarm level</b>	+ 50 %
<b>Shut-down level</b>	+ 70 %

This measurement involves the apparent motion of the shaft surface. Measurements are affected not only by vibration of the shaft, but also by any mechanical run-out of the shaft surface if the shaft is bent or out-of-round. The magnetic/electrical properties of the shaft material at the point of measurement also affect the electrical run-out of the shaft as measured by a proximity probe. The combined mechanical and electrical probe-track run-out of the shaft material at the point of measurement should not exceed 0,012 5 mm peak-to-peak or 25 % of the start-up/satisfactory vibration displacement value, whichever is greater. This run-out should be determined during a slow roll speed test (25 r/min to 400 r/min), when the unbalance forces on the rotor are negligible. Special shaft preparation may be required to achieve satisfactory run-out measurement. Proximity probes should be mounted directly in the bearing housing whenever possible.

The levels given shall apply to the design duty only. When the fan is designed for a variable speed drive, higher levels are possible at other speeds due to unavoidable resonances.

When fans are supplied with variable vanes then the levels shall apply to the condition when the vane control is fully open. It should be noted that, especially at large angles between the vanes and the entry airflow axis, flow separation may occur leading to higher vibration levels.

Fans for installation categories B and D (see ISO 5801 and ISO 13348) shall be tested with an inlet and/or outlet duct having a length of at least two mean duct diameters (see also Annex C).

**EXAMPLE** Recommended guidelines for nominal 150 mm diameter sleeve bearing having a horizontal internal clearance of 0,33 mm

Limits of relative shaft vibration:

- start-up/satisfactory =  $(0,25 \times 0,33 \text{ mm}) = 0,082 5 \text{ mm peak-to-peak}$
- alarm =  $(0,50 \times 0,33 \text{ mm}) = 0,165 \text{ mm peak-to-peak}$
- shut-down =  $(0,70 \times 0,33 \text{ mm}) = 0,231 \text{ mm peak-to-peak}$

Combined mechanical and electrical run-out of the shaft at the point of vibration measurement:

- a) 0,012 5 mm
- b)  $0,25 \times 0,082 5 \text{ mm} = 0,020 6 \text{ mm}$

Choose the greater of the two values: 0,020 6 mm.

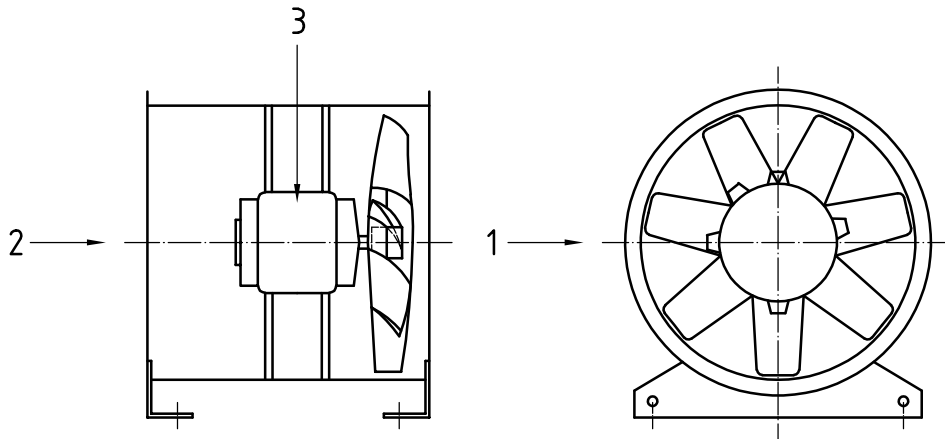

**Key**

- 1 horizontal
- 2 axial
- 3 vertical

**Figure 1 — Three-axis pickup locations for horizontally mounted axial fan**

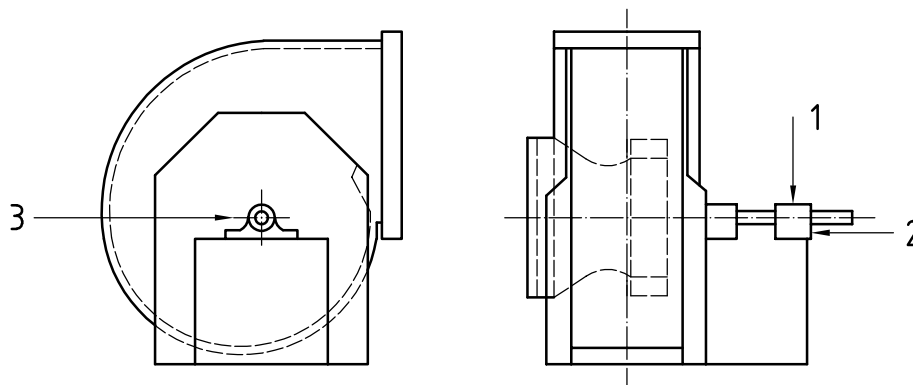

**Key**

- 1 vertical
- 2 axial
- 3 horizontal

**Figure 2 — Three-axis pickup locations for a SWSI centrifugal fan**

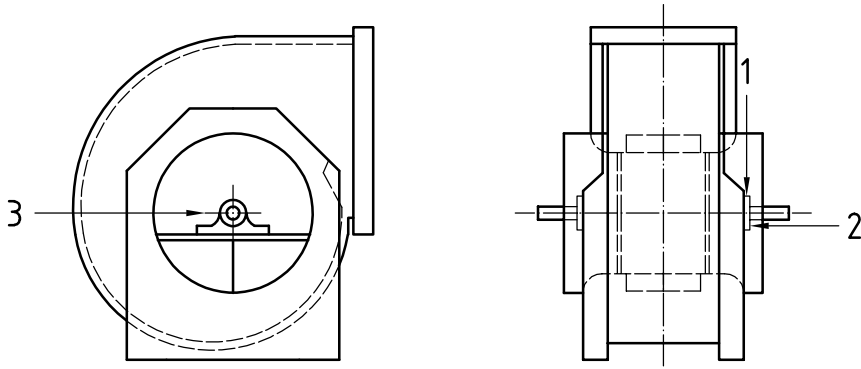

**Key**

- 1 vertical
- 2 axial
- 3 horizontal

**Figure 3 — Three-axis pickup locations for a DWDI centrifugal fan**

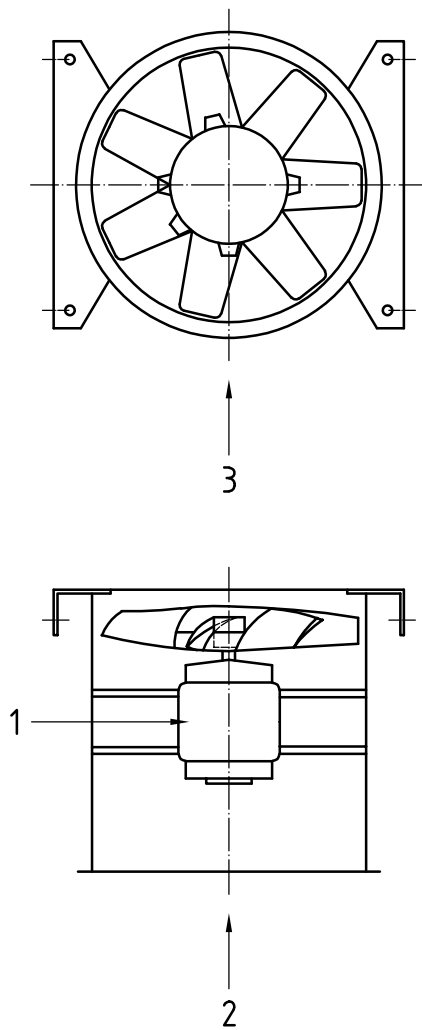

**Key**

- 1 vertical
- 2 axial/vertical
- 3 horizontal

**Figure 4 — Three-axis pickup locations for a vertically mounted axial fan**

## 8.2 Fan support system

Fan installations are classified for vibration severity according to their support flexibility. To be classified as rigidly supported, the fan and support system should have a fundamental (lowest) natural frequency above the running speed. To be classified as flexibly supported, the fan and support system should have a fundamental frequency below the running speed. Generally, a large well-designed concrete foundation will result in a rigid support, whereas a fan mounted on vibration isolators will be classified as flexibly supported. Fans mounted on a steel framework can be in either category, depending on the structural design. In case of doubt, analysis or tests may be required to determine the fundamental natural frequency. Note that, in some cases, a fan could be classified as rigidly supported in one measurement direction and flexibly supported in another.

## 8.3 Fan vibration limits for tests in manufacturer's work-shop

The vibration limits shown in Table 4 apply to assembled fan units. The values shown are velocity, in millimetres per second (mm/s). Filter-In, at fan rotational frequency and are to be taken at the fan bearings.

**Table 4 — Vibration-levels limit for test in manufacturer's work-shop**

Fan application category	Rigidly mounted mm/s		Flexibly mounted mm/s	
	Peak	r.m.s.	Peak	r.m.s.
BV-1	12,7	9,0	15,2	11,2
BV-2	5,1	3,5	7,6	5,6
BV-3	3,8	2,8	5,1	3,5
BV-4	2,5	1,8	3,8	2,8
BV-5	2,0	1,4	2,5	1,8

NOTE 1 Refer to Annex A for conversion of velocity units to displacement or acceleration units for filter-in readings.

NOTE 2 The r.m.s. values given in this Table are preferred. They are rounded to a R20 series as specified in ISO 10816-1. Peak values are widely used in North America. Being made up of a number of sinusoidal wave forms, these do not necessarily have an exact mathematical relationship with the r.m.s. values. They may also depend to some extent on the instrument used.

NOTE 3 The values in this Table refer to the design duty of the fan and its design rotational speed and with any inlet guide vanes "full-open". Values at partial load conditions should be agreed between the manufacturer and user, but should not exceed 1,6 times the values given.

## 8.4 Fan vibration limits for operation *in situ*

The *in situ* vibration level of any fan is not solely dependent on the balance grade. Installation factors, the mass and stiffness of the supporting system, will influence the *in situ* vibration level [22]. Therefore, fan vibration level *in situ* is not the responsibility of the fan manufacturer unless specified in the purchase contract.

The vibration levels in Table 5 are guidelines for acceptable operation of fans in the various application categories. The values shown are for filter-out measurements taken on the bearing housings, and are velocities measured in millimetres per second (mm/s).

The vibration-severity level of newly commissioned fans should be at or below the "start-up" level. As operation of the fan increases with time, it is expected that the vibration level will increase due to wear and other accumulated effects. In general, an increase in vibration is reasonable and safe as long as the level does not reach "alarm."

If the vibration-severity level increases to the "alarm" level, investigation should be initiated immediately to determine the cause of the increase and action taken to correct it. Operation at this condition should be carefully monitored and limited to the time required to develop a programme for correcting the cause of the increased vibration.

If the vibration-severity level increases to the “shut-down” level, corrective action should be taken immediately or the fan should be shut down. Failure to reduce the shut-down level vibration to the acceptable recommended level could lead to bearing failure, cracking of rotor parts and fan-housing structural welds, and ultimately, a catastrophic failure.

Historical data is an important factor when considering the vibration severity of any fan installation. A sudden change in the vibration level may indicate the need for prompt inspection or maintenance. These values should be evaluated and adjusted for each fan installation based on operational or historical data. Transitory changes in vibration level that result from relubrication or maintenance should not be used for evaluating the condition of equipment.

**Table 5 — Seismic vibration limits for tests conducted *in situ***

Condition	Fan-application category	Rigidly mounted mm/s		Flexibly mounted mm/s	
		Peak	r.m.s.	Peak	r.m.s.
Start-up	BV-1	14,0	10	15,2	11,2
	BV-2	7,6	5,6	12,7	9,0
	BV-3	6,4	4,5	8,8	6,3
	BV-4	4,1	2,8	6,4	4,5
	BV-5	2,5	1,8	4,1	2,8
Alarm	BV-1	15,2	10,6	19,1	14,0
	BV-2	12,7	9,0	19,1	14,0
	BV-3	10,2	7,1	16,5	11,8
	BV-4	6,4	4,5	10,2	7,1
	BV-5	5,7	4,0	7,6	5,6
Shutdown	BV-1	Note 1	Note 1	Note 1	Note 1
	BV-2	Note 1	Note 1	Note 1	Note 1
	BV-3	12,7	9,0	17,8	12,5
	BV-4	10,2	7,1	15,2	11,2
	BV-5	7,6	5,6	10,2	7,1

NOTE 1 Shutdown levels for fans in fan-application grades BV-1 and BV-2 should be established based on historical data.

NOTE 2 The r.m.s. values given in this Table are preferred. They are rounded to a R20 series as specified in ISO 10816-1. Peak values are widely used in North America. Being made up of a number of sinusoidal wave forms, these do not necessarily have an exact mathematical relationship with the r.m.s. values. They may also depend to some extent on the instrument used.

## 9 Other rotating components

Accessory rotating components which may affect fan-vibration levels include drive sheaves, belts, coupling, and motor/driver devices. When a fan is ordered from the manufacturer in a bare condition, (i.e., no drive and/or motor supplied and/or installed by the manufacturer), it is not always practical for the manufacturer to perform a final assembly test run for vibration levels. Therefore, though the impeller may have been balanced by the manufacturer, the customer is not assured of a smooth-running assembled fan until the drive and/or driver are connected to the fan shaft and the unit is tested for start-up vibration levels.

It is common for assembled fans to require trim balancing to reduce the vibration level to the start-up level. The final assembly test run is recommended for all new BV-3, BV-4 and BV-5 fan installations before commissioning for service. This will establish a baseline for future predictive maintenance efforts.

The fan manufacturer cannot be responsible for the effects of vibration of drive components added after the factory test run. For additional information on the balance quality or vibration of components, refer to the appropriate references given in Clause 2.



## 10 Instruments and calibration

### 10.1 Instruments

Instruments and balancing machines used shall meet the requirements of the task and be within current calibration. See Clause 8 of ISO 1940-1:1986. The calibration period for the instrument should be that recommended by the instrument manufacturer. Instruments shall be in good condition and suitable for the intended function for the complete duration of the test.

Personnel operating instruments shall be familiar with the instruments and shall possess enough experience to detect a possible malfunction or degradation of the instrument performance. When instruments require corrective measures or calibration, they shall be removed from service until corrective action is taken.

### 10.2 Calibration

All instruments shall be calibrated against a known standard. The complexity of the calibration may vary from a physical inspection to a complete calibration. Traceable use of a calibrated weight to determine residual unbalance such as described in 8.3 of ISO 1940-1:1986 is one accepted method of calibrating instrumentation.

## 11 Documentation

### 11.1 Balance

Written certification of the balance achieved for an individual rotor shall be provided upon request when negotiated. In such cases, it is recommended that the following information be included in the balance-certification report:

- a) balance-machine manufacturer, model number;
- b) overhung or between centres;
- c) balance method, single plane, two-plane;
- d) mass of rotating assembly;
- e) residual unbalance in each correction plane;
- f) allowable residual unbalance in each correction plane;
- g) balance quality grade required;
- h) acceptance criteria: pass/fail;
- i) balance certificate, if required.

Keeping a written record on an individual rotor is not always practical. When this is the case, the manufacturer's records or standard operating procedures shall be sufficient evidence of balance achievement.

### 11.2 Fan vibration

Written certification of the vibration level achieved for an individual fan shall be provided upon request when negotiated. In such cases, it is recommended that the following information be included in the vibration certification report:

- a) instrumentation used;
- b) attachment of transducer;

- c) fan operating point (volume flow rate, pressure, power);
- d) fan operating speed;
- e) flexible or rigid mount;
- f) description of measurements:
  - 1) position and axis,
  - 2) units of measure used and reference levels,
  - 3) frequency, bandwidth, filter-in or filter-out.
- g) allowable vibration level(s);
- h) measured vibration level(s);
- i) acceptance criteria: pass/fail;
- j) vibration certificate if requested.

Keeping a written record on an individual fan is not always practical. When this is the case, the manufacturer's records or standard operating procedures shall be sufficient evidence of vibration level achievement.

### **11.3 Certificates**

Figure 5 gives an example of a Balance Vibration Certificate. It is for illustrative purposes only and any other certificate which includes the necessary information outlined in 11.1 and/or 11.2 is acceptable.

**Certificate of balance/vibration**

Work order No.		Customer order No.	
Fan type		Customer	
Description		Fan serial No.	
Drawing No.		Specification	
Impeller diameter			
Impeller rotation speed			
Electrical supply	V    φ    Hz		

This is to certify that the above item has been balanced to within the permitted residual unbalance which complies with grade G of ISO 1940-1 and is in accordance with the requirements of ISO 14694 and ISO 14695.

For position of transducers see sketch.

Balance    Filtered readings    Filter bandwidth    \_\_\_\_\_ Hz

Transducer position	Velocity	mm/s	<input type="checkbox"/>	Rotational	Hz	<input type="checkbox"/>	Balance grade
	Peak		<input type="checkbox"/>	Frequency	r/min	<input type="checkbox"/>	
A							
B							

To convert from r.m.s. to peak-to-peak value, multiply by 1,4141/4  
 To convert from r.m.s. to peak value multiply by 0,707

To obtain displacement in μm peak =  $\frac{V_{\text{peak-to-peak}} \times 60\,000}{2X \times r/\text{min}}$

Sketch

Vibration    (Overall readings)

Mode	Transducer position			
	1	2	3	4

All readings are vibrational displacement/velocity/acceleration

Units are μm peak-to-peak                      mm/s r.m.s.                      m/s<sup>2</sup> r.m.s.

mm/s peak                                              m/s<sup>2</sup> peak

V<sub>dB</sub> reference level 10<sup>-9</sup> m/s                      A<sub>dB</sub> reference level 10<sup>-6</sup> m/s<sup>2</sup>

Fan mounting  Free     Rubber A/V                       Spring A/V     Suspended   

EQUIPMENT    Transducers    \_\_\_\_\_

Analyser    \_\_\_\_\_

Tested by    \_\_\_\_\_    Sign for and on behalf of    \_\_\_\_\_

Date    \_\_\_\_\_

**Figure 5 — Example of report form for balancing and vibration**

## Annex A (informative)

### Relationship of vibration displacement, velocity and acceleration for sinusoidal motion

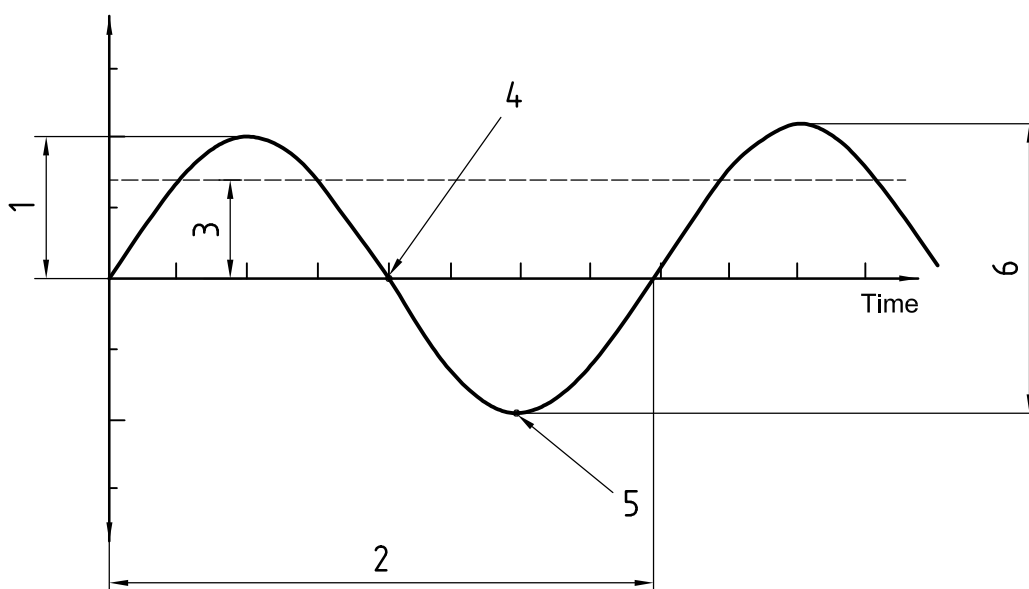

#### Key

- 1 displacement
- 2 period (amount of time to complete one cycle)
- 3 r.m.s
- 4 peak velocity (when displacement = 0)
- 5 peak acceleration (when displacement is at peak)
- 6 peak-to-peak displacement

**Figure A.1**

Generally, there is no simple relationship between broad-band acceleration, velocity and displacement; nor is there between peak (o-p), peak-to-peak (p-p) root mean square (r.m.s.) and average values of vibration. However, when the vibration is totally or predominantly at a single frequency (e.g. due to residual unbalance) or it is measured "filter-in", then the following relationships exist, independent of the system of units involved:

$$V_{\text{r.m.s.}} = \frac{V_{\text{peak}}}{\sqrt{2}}$$

$$A_{\text{r.m.s.}} = \frac{A_{\text{peak}}}{\sqrt{2}}$$

$$D_{\text{r.m.s.}} = \frac{D_{\text{peak-to-peak}}}{2 \times \sqrt{2}}$$

The following relationships also exist, expressed in the SI system of units:

Displacement	$D_{\text{peak-to-peak}}$ , in millimetres;
Velocity	$V_{\text{peak}}$ , in millimetres per second;
Acceleration	$A_{\text{peak}}$ , in metres per second squared ( $1 g = 9,806\ 65 \text{ m/s}^2$ );
Frequency	$f$ , in Hertz;

**Relationship equations**

EXAMPLE 0,10 mm, peak-to-peak, at 1 800 r/min (30 Hz)

$$V_{\text{peak}} = \pi \cdot f \cdot D_{\text{peak-to-peak}}$$

$$V_{\text{peak}} = \pi \times (30) \times (0,10) = 9,42 \text{ mm/s}$$

$$A_{\text{peak}} = \frac{2 \cdot (\pi f)^2 D_{\text{peak-to-peak}}}{1000 \cdot g}$$

$$A_{\text{peak}} = \frac{2 \times (\pi \times 30)^2 \times (0,10)}{(1000) \times g} = 0,181 \text{ g}$$

$$D_{\text{peak-peak}} = \frac{V_{\text{peak}}}{\pi \cdot f}$$

$$D_{\text{peak-peak}} = \frac{9,42}{\pi \times 30} = 0,10 \text{ mm}$$

$$D_{\text{peak-peak}} = \frac{1000 \cdot g \cdot A_{\text{peak}}}{2 \cdot (\pi \cdot f)^2}$$

$$D_{\text{peak-peak}} = \frac{(1000) \times (g) \times (0,181)}{2 \times (\pi \times 30)^2} = 0,10 \text{ mm}$$

$$V_{\text{peak}} = \frac{1000 \cdot g \cdot A_{\text{peak}}}{2 \cdot \pi \cdot f}$$

$$V_{\text{peak}} = \frac{(1000) \times (g) \times (0,181)}{2 \times \pi \times 30} = 9,42 \text{ mm/s}$$

$$A_{\text{peak}} = \frac{2 \cdot \pi \cdot f \cdot V}{1000 \cdot g}$$

$$A_{\text{peak}} = \frac{2 \times \pi (30) \times (9,42)}{(1000) \times g} = 0,181 \text{ g}$$

The following relationships exist, expressed in the SI system of units:

Displacement  $D_{\text{r.m.s.}}$ , in millimetres;

Velocity  $V_{\text{r.m.s.}}$ , in millimetres per second;

Acceleration  $A_{\text{r.m.s.}}$ , in metres per second squared;

Frequency  $f$ , in hertz.

**Relationship equations**

EXAMPLE 0,035 4 mm to 1 800 r/min (30 Hz)

$$V_{\text{r.m.s.}} = 2 \cdot \pi \cdot f \cdot D_{\text{r.m.s.}}$$

$$V_{\text{r.m.s.}} = 2 \times \pi \times (30) \times (0,035 4) = 6,67 \text{ mm/s}$$

$$A_{\text{r.m.s.}} = \frac{4 \cdot (\pi f)^2 \cdot D_{\text{r.m.s.}}}{1000}$$

$$A_{\text{r.m.s.}} = \frac{4 \times (\pi \times 30)^2 \times 0,035 4}{1000} = 1,26 \text{ m/s}$$

$$D_{\text{r.m.s.}} = \frac{V}{2 \cdot \pi \cdot f}$$

$$D_{\text{r.m.s.}} = \frac{6,67}{2 \times \pi \times (30)} = 0,035 4 \text{ mm}$$

$$D_{\text{r.m.s.}} = \frac{1000 \cdot A_{\text{r.m.s.}}}{4 \cdot (\pi f)^2}$$

$$D_{\text{r.m.s.}} = \frac{1000 \times 1,26}{4 \times (\pi \times 30)^2} = 0,035 4 \text{ mm}$$

$$V_{\text{r.m.s.}} = \frac{1000 \cdot A_{\text{r.m.s.}}}{2 \cdot \pi \cdot f}$$

$$V_{\text{r.m.s.}} = \frac{1000 \times 1,26}{2 \times \pi \times (30)} = 6,67 \text{ mm/s}$$

$$A_{\text{r.m.s.}} = \frac{2 \cdot \pi \cdot f \cdot V_{\text{r.m.s.}}}{1000}$$

$$A_{\text{r.m.s.}} = \frac{2 \times \pi \times (30) \times 6,67}{1000} = 1,26 \text{ m/s}$$

## Annex B (informative)

### Assembly practices for balancing in a balancing machine

#### B.1 Directly driven fans

##### B.1.1 General

Fan impellers which are intended to be fitted directly to the shaft of an electric motor must be balanced to the same conventions to that which the electric motor has been balanced.

Electric motors complying with earlier editions of IEC 60034-14 will have been balanced with a full key attached to the shaft. This International Standard has now been revised, however, and motors produced according to the revised standard will be balanced with a half key on the shaft so as to comply with the requirements of ISO 8821. Such motors are to have the shaft marked with the letter H, to indicate that the balancing was performed using the half-key convention, and any fitments to the motor, such as fans, are also to be marked. (See ISO 8821 for further information on marking.)

##### B.1.2 Motors balanced according to the full-key convention

Fan impellers which are to be fitted to electric motors balanced to the full-key convention should be balanced on a tapered mandrel, without a key being fitted to the fan impeller.

##### B.1.3 Motors balanced according to the half-key convention

Fan impellers which are to be fitted to electric motors which have been balanced to the half-key convention can:

- a) have the keyway cut after balancing, if the impellers have a steel hub,
- b) be balanced, on a tapered mandrel, and with the keyway in the impeller filled with a half-height key, and
- c) be balanced on a mandrel, in which a keyway or keyways have been cut (see B.3) and with a full key fitted.

#### B.2 Indirectly driven fans

Wherever possible, the complete rotating assembly, including the fan wheel, shaft and pulley/coupling, should be balanced as a unit. When this is not practical, however, the impeller shall be balanced on a mandrel (see B.3) using the same convention as used for the shaft.

#### B.3 Mandrel

Mandrels are temporary shafts used for mounting fan impellers when they are being balanced. Mandrels should be

- a) kept as light as possible,

- b) handled carefully at all times and checked regularly to ensure that they are still in balance, and
- c) preferably of the tapered type, as this reduces the errors due to eccentricity caused by tolerances in the dimensions of the bore and mandrel. If using tapered mandrels, the correct distances from the balance planes to the bearings shall be employed in the computation of balance.

Should a parallel mandrel be used, then a keyway shall be cut in the mandrel and a full key fitted to transmit torque between the mandrel and fan.

Alternatively, two keyways, spaced at  $180^\circ$ , may be cut in the mandrel so that a method known as a reversal test can be used. The fan is first checked for balance using one full key and one half key to fill the other keyway in the mandrel. The fan is then rotated through  $180^\circ$  relative to the mandrel and checked again. The differential value of the two unbalance measurements represents residual unbalance in the mandrel and the universal joint drive shaft. Half the difference between the two measurements represents unbalance in the fan rotor.

## Annex C (informative)

### Sources of vibrations

#### C.1 General

There are many sources of vibration within any fan installation and some of the frequencies which occur may be directly attributable to the nature of the installation. This Annex can only deal with the more common sources of vibration which can occur on most fans. As a general rule, any looseness in the support system will cause deterioration in the vibration behaviour. Informative values are given in Table C.1.

#### C.2 Unbalance

This is the major source of vibration in fans and is characterized by the frequency of vibration equivalent to the rotational speed (1 r/s) of the machine. It is caused by the centre of the axis of rotating mass being eccentric or inclined to the axis of rotation and this may be the result of irregular distribution of rotating mass, the summation of tolerances causing the impeller to be eccentric on its shaft, the shaft being bent, or any combination of these. Vibration as a result of out of balance will be predominantly in the radial direction.

The shaft can become temporarily bent due to uneven heating, either as a result of friction between rotating and fixed components, by electrical effects (see C.6), or in the case of a static fan, due to uneven air temperatures. Permanent bends can occur as a result of changes in material properties, as a result of mistreatment, or in the case of a separately mounted fan and motor, as a result of a misaligned coupling (see C.3).

During service, an impeller could become unbalanced due to the uneven build-up of airborne contaminants. In a hostile environment, unbalance could be due to uneven erosion or corrosion of the impeller.

The effects of out of balance can be overcome by trim balancing at suitable planes, but the source of the unbalance should be determined, remedial work carried out and repeatable behaviour established, before any balancing is undertaken.

#### C.3 Misalignment

This can occur when the drive motor and the fan are separately mounted and coupled together by drive belts or a (flexible) coupling. Misalignment is sometimes characterized by a frequency of vibration coinciding typically with once and twice the rotational speed (1 and  $2 \times r/s$ ). It will be predominantly in the radial direction, when a parallel offset occurs, but when there is an angular offset, it may be dominant in an axial direction.

The misalignment of shafts mounted in series, results in an angled joint through which the shafts rotate. When rigid couplings are employed, alternating forces are introduced into the system, resulting in fatigue loads on the shafts and the couplings. The use of flexible couplings will significantly reduce these loads.

#### C.4 Aerodynamic excitation

Excitation can be caused by interaction between the impeller and stationary obstructions such as guide vanes, the cut off (centrifugal fans), motor or bearing supports, inadequate running clearances or poorly designed upstream or downstream airways. The essential feature is that some regular pattern, repeating each revolution of the impeller, is imposed on the otherwise random force fluctuations between the impeller blades and the air. Vibrations will be observed at multiples of the blade-passing frequency, i.e. the product of the rotational speed, in revolutions per second (r/s), and the blade number.



Aerodynamic stall, caused by air separation from blade surfaces and subsequent wake shedding, produces a broad-band vibration which will change in magnitude and shape with varying fan load.

Rotating aerodynamic stall is characterized by asynchronous and particularly sub-synchronous (less than  $1 \times r/s$ ) frequencies which will be unstable and not a function of rotational speed. High vibrations will be evident on the fan casing and any ducting.

Surge can occur when there is a significant mismatch in the system requirements compared to the fan capability. Its occurrence will result in impulsive inputs to the fan supports and there will be strong acoustic evidence that it is happening.

When blade vibrations occur as a result of any of the above effects, it will probably be necessary to investigate them using separate transducers rather than the vibration pick-ups in the normal positions.

### C.5 Oil whirl

Oil whirl can occur principally on pressure-lubricated sleeve or journal-type bearings and has a characteristic frequency just below half-rotational speed unless the machine is operating above its first critical speed, in which case the oil whirl will be observed at the first critical speed and is sometimes then known as resonant whirl or oil whip.

### C.6 Electrical sources

Uneven heating of the electrical rotor can lead to bending which then results in out-of-balance effects ( $1 \times r/s$ ).

In the case of induction motors, the appearance of a frequency corresponding to the number of rotor bars times the rotational speed, in revolutions per second ( $r/s$ ), signifies effects emanating from the stator bars, while conversely, a frequency corresponding to the number of stator bars times rotational speed, in revolutions per second ( $r/s$ ), signifies effects emanating from the rotor bars.

It is characteristic of many vibrations induced by electrical sources that they disappear immediately when the electrical supply is removed.

### C.7 Disturbances from belt drives

There are, in general, two types of vibration problems associated with belt drives, namely: the reaction of the belts to other disturbing forces, and vibration due to actual problems with the belts.

The former is the most common occurrence when, although the belts are vibrating, they are merely reacting to some other disturbing force, hence replacement of the belts will not cure the problem. Typical sources are excessive unbalance in the drive system, eccentric pulleys, misalignment and mechanical looseness. Thus, an analysis should be made to determine the source of the vibration before the belts are replaced.

If the belts are reacting to some disturbing force, the frequency of the belt vibration will probably be the same as the disturbing frequency. When this is the case, a stroboscopic light can be used to identify the source, since at the vibrational frequency, the source will appear stationary.

On multibelt drives, the source of the vibration can be excessively amplified if the belts are not of equal tension.

Occurrences when the belts are the source of the vibration will be due to physical defects of the belts such as cracks, hard spots, soft spots, lumps on the belt faces, pieces broken off, etc. With V belts, variation in width will cause the belt to ride up and down in the pulley grooves, creating vibration through variation in belt tension.

When the belts are actually the source of the vibration, the frequency at which this occurs will usually be some multiple (1, 2, 3 or 4 s) times the belt revolutions per unit time. The particular frequency will depend on the nature of the problem as well as the number of pulleys and idlers.

In some cases, the vibration amplitude will be unsteady. This is particularly true of multiple belt drives.

Table C.1 — Informative values

Cause of vibration (relative probability: 1 THRU 10)		Predominant frequencies										Predominant amplitude						Predominant noise					Remarks									
		C-40 %	40 %-50 %	50 %-100 %	1 × RPM	2 × RPM	Higher multiples	½ RPM	¼ RPM	Lower multiples	Odd frequencies	Very high frequency	Probable location						Low "Rumble"	Loud "roar"	Hum	Periodic "Beat"		High pitch "Whine"	Very high, loud	Very high, squeal	Ultrasonic					
													Horizontal	Vertical	Axial	Rotor shaft	Bearings	Casing										Foundation	Piping	Coupling	Phase (No. of reference marks)	
		Direct																														
Unbalance	Initial unbalance			10																										Most common cause of vibration whose amplitude is proportional to the amount of unbalance. May be aggravated by, or may produce, complications such as seal rubs, bearing failures or resonances. (Overhung rotors may show relatively high axial vibration.)		
	Shaft bow-lost parts			10																												
Misalignment looseness and distortion	Misalignment				4	5	1																							Misalignment appears as a large axial vibration. Use dial indicators or other methods for positive diagnosis. May produce friction or deflection forces which can be severe. Looseness creates many problems. A small amount may allow violent vibration. Looseness in bearings may be mistaken for oil whirl. Usually accompanied by unbalance and/or misalignment. Distortion causes vibration indirectly by generating misalignment, causing internal rubs or uneven bearing contact. Piping forces and foundation distortion often cause resonance problems. Rubs are characterized by the presence of many frequencies all over the spectrum, often ultrasonic. Produce "Hot spots" resulting in bent shaft, bearing cavitation and resonances.		
	Mechanical looseness					8	1		1																							
	Clearance induced vibration	1	8	1																												
	Foundation distortion	2			5	2				1																						
	Case distortion	1			8	½	½			5	4	1	9	1																		
	Seal rub	1	1		2	1	1			1	1	4	3	8	1	1																
	Rotor rub (axial)	2			3	1	1			1	1	4	3	7	1	2																
Piping forces				4	5	1																										



Table C.1 (continued)

Cause of vibration (relative probability: 1 THRU 10)	Predominant frequencies										Predominant amplitude						Predominant noise						Remarks														
	C-40 %	40 %-50 %	0 %-100 %	1 × RPM	2 × RPM	Higher multiples	½ RPM	¼ RPM	Lower multiples	Odd frequencies	Very high frequency	Horizontal	Probable location						Low "Rumble"	Loud "roar"	Hum	Periodic "Beat"		High pitch "Whine"	Very high, loud	Very high, squeal	Ultrasonic										
													Vertical	Axial	Rotor shaft	Bearings	Casing	Foundation										Piping	Coupling	Phase (No. of reference marks)							
Direct		Vertical		Axial		Rotor shaft		Bearings		Casing		Foundation		Piping		Coupling		Phase (No. of reference marks)		Low "Rumble"		Loud "roar"		Hum		Periodic "Beat"		High pitch "Whine"		Very high, loud		Very high, squeal		Ultrasonic			
Resonance	Resonant vibration			10							4	4	2	2	1	2	3	2	Erratic	4	4	3	3										Resonance — Only amplifies vibrations from other sources, cannot generate vibration. Can create highly dangerous situations by amplifying normal vibration in rotating machines or from pulsations in piping. May cause rotors or bearing abnormalities such as resonant whirl. Torsional vibration is not usually noticeable externally since motion is superimposed on the rotation similar to the action of a washing-machine agitator. Failures may occur without warning unless gearing is involved resulting in noise; also bearing and case vibration. Special transducers are usually required. Torsion resonant frequencies coinciding with electrical frequencies can become very serious.				
	Sub-harmonic resonance						10			3	3	4	2	2	2	2	2	2	Rocking	8	8	2	2														
	Harmonic resonance							10		4	4	2	2	1	1	2	3							4	2	4											
	Casing resonance				8	1	1			5	4	1	4	4	1	1						2	2	6													
	Support resonance				8	1	1			5	4	1	2	5	2	1						2	2	6													
	Foundation resonance				8	1	1			4	3	3	1	4	4	1						1	8	1													
	Torsional resonance				4	2	2															1	2	3	1	1											
	Miscellaneous basic causes	Bad drive belts						10 Belts			4	3	3	5	3	2				(1) - (2) Erratic	1	1	3	5													
		Reciprocating forces				3	5	2			3	6	1	5	3	1	1						8	2													
		Aero/hydro forces				2		6			2	5	4	1	4	3	2	1		(1) or Multiple	3	2	1	2	2												
		Friction-induced whirl	8	1	1						5	4	1	8	2							6	2	2													
Oil whirl										5	4	1	8	2							6	1	3				2										
Resonant whirl			10							5	4	1	2	2	2	2					6	2	2														
Dry whirl										10	4	3	3	4	2	1	1				Erratic																



## Annex D (informative)

### Equation of vibration

#### D.1 Forces causing vibration

The fan and its parts may be likened to a spring-mass system and an understanding of this fact is useful in resolving many vibrational problems. It is also of importance in revealing the causes of resonance.

Every fan will have three basic properties.

- a) Mass  $m$  measured, in kilograms. The force due to the mass of the system is an inertia force or a measure of the tendency of the body to remain at rest.
- b) Damping  $C$  is the damping force per unit velocity of a system. It is a measure of the slowing down of vibrations, and is given in newtons second per millimetre.
- c) Stiffness  $k$  is a measure of the force required to deflect part of the fan through unit distance, expressed in newtons per millimetre.

The combined effects of these restraining forces determine how a fan will respond to a given vibratory force e.g. unbalance. Thus we may state that:

$$m\ddot{e}_p + C\dot{e}_p + ke_p = M_u\omega^2 r \sin(\omega t + \phi) = M\omega^2 e \sin(\omega t - \phi_1)$$

or

$$-me_p\omega^2 \sin\omega t + Ce_p\omega \sin(\omega t + \pi/2) + ke_p = M_u\omega^2 r \sin(\omega t - \phi) = M\omega^2 e \sin(\omega t - \phi)$$

where

$e$	= Displacement of centre of gravity from centre of rotation	m;
$e_p$	= Displacement of part due to vibratory force	m;
$M$	= Mass of rotating parts	kg;
$M_u$	= Mass of residual unbalance	kg;
$r$	= Distance of unbalance from rotating centre	m;
$\phi$	= Phase angle between exciting force and actual vibration	rad;
$\omega$	= Angular velocity	rad-s;
$m$	= Total mass or mass being considered	kg.

or

Inertia force + Damping force + Stiffness force = Vibratory force

It will be seen that the three restraining forces are not working together, indeed the inertia and stiffness forces are 180° out of phase. There will be a certain frequency when they are equal and will cancel each other out. Then there will only be the damping force (which is 90° out of phase) to oppose the vibratory force.

Consider a system with no damping, then

$$-me_p \omega^2 \sin \omega t + ke_p \sin \omega t = M\omega^2 e \sin(\omega t - \phi)$$

The displacement of the system due to the vibratory force can be expressed as

$$e_p = \frac{M\omega^2 e \sin(\omega t - \phi)}{(k - m\omega^2) \sin \omega t}$$

The displacement,  $e_p$  will become infinitely large for any value of  $t$ , when the expression  $k - m\omega^2$  becomes zero, thus the critical rotational frequency  $\omega_c$  at which this occurs is

$$\omega_c = \sqrt{k/m}$$

or more specifically for fans, the critical speed  $N_c$ , in revolutions per minute (r/min), is

$$N_c = \omega_c \times 60/(2\pi) = 60/2\pi \times \sqrt{k/m}$$

This condition, known as resonance, can cause high levels of vibration, and although minimized by the optimization of damping, should be avoided by operating at a speed well away from the critical speed.

All fans, together with their supporting bases, consist of a number of different spring-mass systems, each having its own natural frequency possible with various degrees of freedom (usually simplified to six) and a different resonant frequency for each. Whilst unbalance is usually the major exciting force, there will be numerous other sources such that resonance can be a common problem. In these other cases, the force due to out-of-balance would be replaced in the equation by forces due to electromagnetic, aerodynamic or other factors, as appropriate.

## D.2 Vibration energy

The force causing the vibration of a fan has already been established as:

$$\text{Vibratory force} = M\omega^2 e \sin(\omega t - \phi)$$

Since vibration is assessed in linear terms along an axis, it is useful to express the vibratory force as a linear vector. The expression in terms of an r.m.s. value becomes:

$$\text{Linear vibratory force} = 1/\sqrt{2} M\omega^2 e$$

Similarly, the r.m.s. displacement of the rotating masses is given as  $1/\sqrt{2} e$ . Thus, the kinetic energy of the rotating masses, or the potential to induce vibratory motion, is given as the product of the applied force and the displacement due to the force i.e.:

$$\text{Vibration energy} = 1/2 M (\omega e)^2$$

From the derivation of G grades in 7.3, the expression of vibration energy can be rewritten:

$$\text{Vibration energy} = 1/2 MG^2$$

## Annex E (informative)

### Vibration and supports

An adequate support structure or base is necessary to ensure a smooth, trouble-free fan installation. A baseframe of structural steel or a reinforced concrete base is always essential to support the fan, motor and drive combination and maintain good alignment. Sometimes economies in base construction result in an inadequate support. It then becomes difficult to obtain and maintain this good alignment. This will become apparent if vibration readings always point to alignment changes, especially on doweled machines. The foundations upon which the base is installed may also affect the fan and motor vibration. Foundation resonance will occur if the structure has a natural frequency close to the fan or motor speed. This may be determined by taking vibration readings at intervals on and around the foundations, the bearing supports and the surrounding floor. Often there is a significant disparity between the amplitude of the vertical vibration and the horizontal when a resonant condition exists. The vibration will be reduced by stiffening the foundation structure or increasing the foundation mass. Whilst correcting unbalance and/or coupling misalignment will reduce the exciting force, the conditions conducive to high vibration will still exist. This means that a better balance grade and alignment than normally specified will always be required when the fan and its supporting structure are in, or near, resonance. Nevertheless, such situations are not to be recommended and the preferred solution is to increase the mass and/or stiffness of the supporting structure or concrete block.



## Annex F (informative)

### Out of balance and bearing reactions

The way in which the various unbalances may be combined and corrected is best shown by examples:

**EXAMPLE 1** A 1 000 mm, 1 800 r/min maximum axial fan impeller for a heat-transfer application weighing 25 kg is to be statically balanced by adding weight at a 180 mm radius. Within what limits should the weights be adjusted?

The G 6.3 balance quality grade is appropriate. At 30 r/s, reference to Figure F.1 (abstracted from ISO 1940-1) gives  $\Delta e = 32 \mu\text{m}$  as the maximum centre-of-gravity eccentricity. The corresponding maximum out-of-balance weight is:

$$\Delta m = \frac{\Delta e \cdot M}{r} = \frac{32 (\mu\text{m}) \times 25 (\text{kg})}{180 \text{ mm}} = 4,5 \text{ gm} = 4,4 \text{ gm}$$

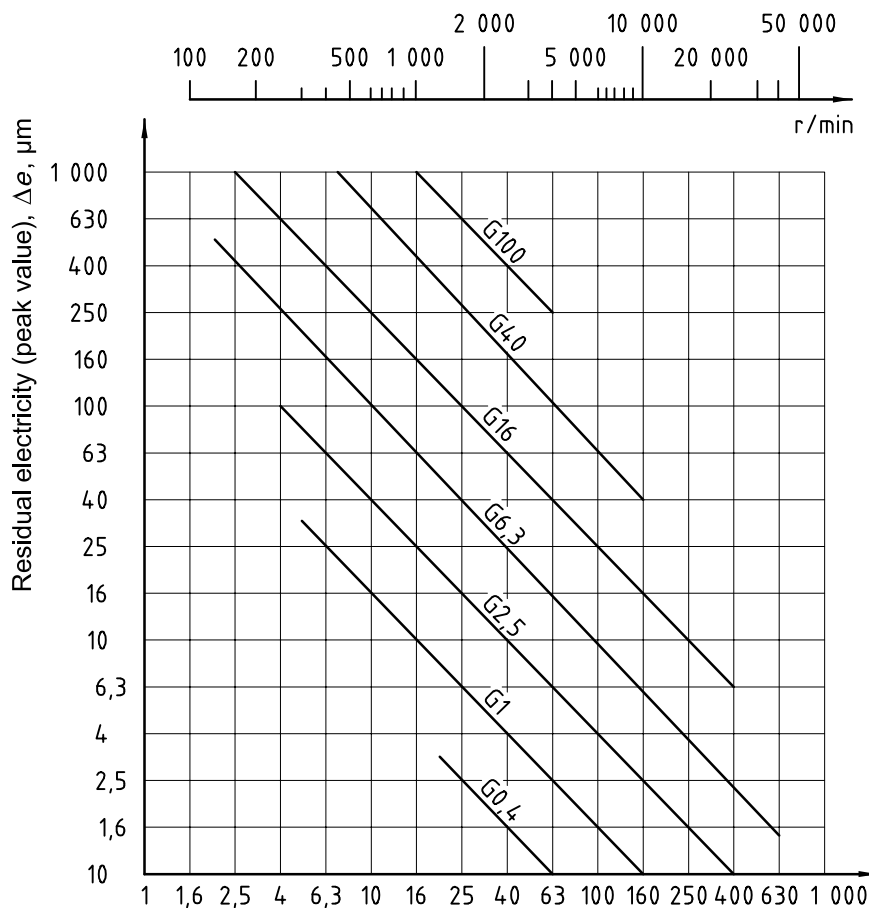

Figure F.1 — Permissible eccentricity for balance quality grades

EXAMPLE 2 Figure F.2 illustrates the operation of dynamically balancing a 250 mm diameter, 3 600 r/min maximum (60 r/s) multivane impeller weighing 2,5 kg. Two counterbalance weights are to be attached at 110 mm radius in correcting planes 150 mm apart.

Initial static unbalance: 240 gm·mm, 50 mm from one plane.

Initial couple unbalance: 120 gm·mm × 150 mm at right-angles to the static unbalance.

The 240 gm·mm static counterbalance components will be divided between the correcting planes so as to give equal and opposite couples:

$$160 \text{ gm}\cdot\text{mm} \times 50 \text{ mm} = 80 \text{ gm}\cdot\text{mm} \times 100 \text{ mm}$$

The couple counterbalance components of 120 gm·mm in each correcting plane will directly oppose the couple unbalance moments.

Combining the counterbalance vectors in each plane gives 200 gm·mm and 144 gm·mm respectively in the directions shown. These determine the following counterbalance weights:

$$\frac{200 \text{ (gm}\cdot\text{mm)}}{110 \text{ mm}} = 1,82 \text{ gm}$$

$$\frac{144 \text{ (gm}\cdot\text{mm)}}{110 \text{ mm}} = 1,31 \text{ gm}$$

EXAMPLE 3 Figure F.2 illustrates the impeller of the last example overhung from a housing weighing 1,5 kg with bearings 80 mm apart.

Suppose the impeller to have been balanced just to the G 6.3 limits, viz.  $e = 16 \mu\text{m}$  at 60 r/s both statically and dynamically.

Static unbalance:

$$\Delta e \cdot M = 2,5 \text{ (kg)} \times 16 \text{ (}\mu\text{m)} = 40 \text{ gm}\cdot\text{mm}$$

Couple unbalance:

$$\begin{aligned} \Delta mra &= \frac{\Delta e m a}{2} = \frac{2,5 \text{ (kg)} \times 16 \text{ (}\mu\text{m)} \times 150 \text{ (mm)}}{2} \\ &= 3\,000 \text{ gm}\cdot\text{mm}^2 \end{aligned}$$

Note that these are, in each case, one-sixth of the initial unbalance.

The static unbalance will produce a reaction unbalance force of 40 gm·mm which will be located half-way between the bearings. These two opposite forces, 140 mm apart, will produce a couple unbalance of  $40 \times 140 = 5\,600 \text{ gm}\cdot\text{mm}^2$  to be resisted by the bearings.

Units expressed in gm·mm, except those indicated on the drawing

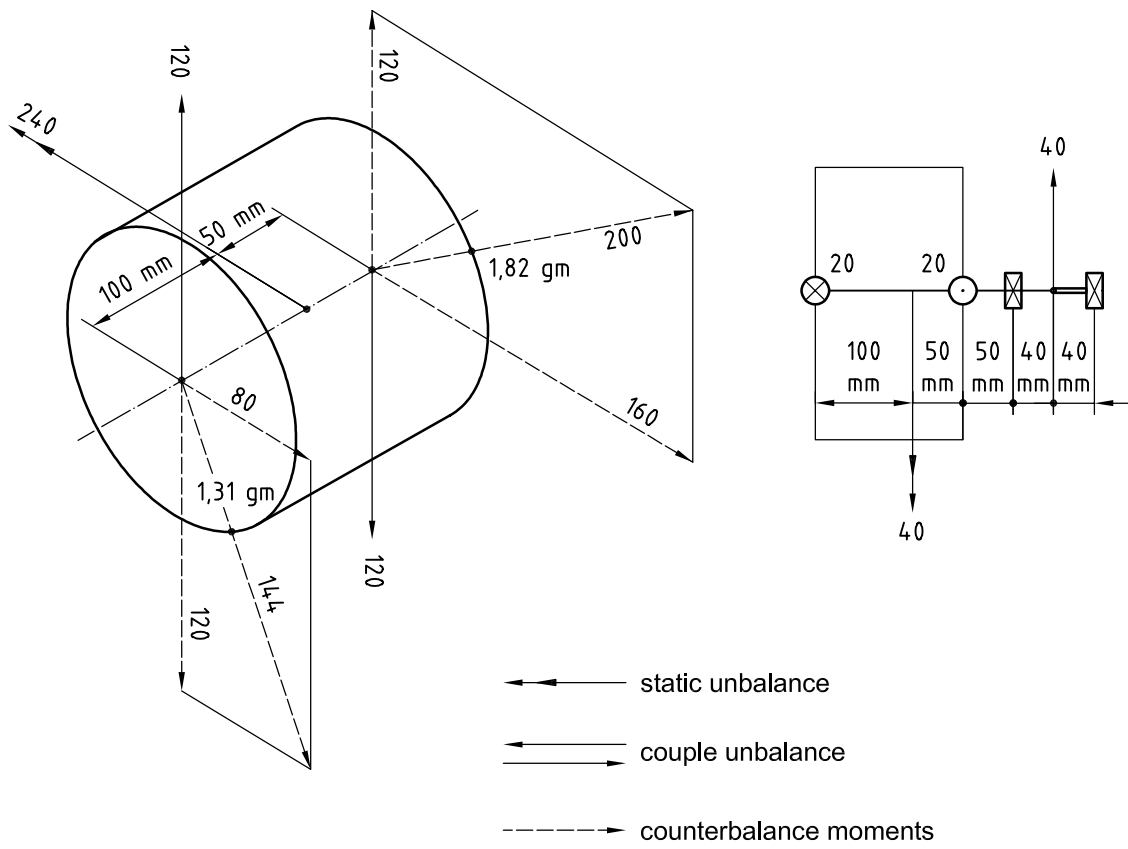

Figure F.2 — Example of dynamic balance correction

## Annex G (informative)

### Condition monitoring and diagnostic guidelines

The basic principle of condition monitoring is to monitor a suitable measurement, so that any upward trend can be detected and taken as an indication that a problem exists. Condition monitoring is appropriate when faults develop slowly and when the deterioration is reflected in a measurable physical property.

Fan vibration, which is the result of physical defects, can be monitored on a regular basis and, when an increase in level is noted, a more frequent monitoring and detailed analysis can be made. In this way, a vibration-frequency analysis can identify the cause of a vibration anomaly, so that corrections can be prescribed and scheduled long before the fault becomes serious. An accepted indication that remedial action is required is when the monitored levels exceed the normal level by a factor of 1,6, or 4 dB.

There are several basic steps to implementing a condition-monitoring schedule, and these can be summarized as follows.

- a) Identify the fan's condition and normal, acceptable vibration level. Note that this will probably be different from the factory test owing to differences in mounting etc.;
- b) Select vibration measurement points;
- c) Determine the interval for measurements;
- d) Establish a data-recording system;
- e) Establish criteria for assessing the fan's condition; vibration limits, trends, experience from similar machines.

As the majority of fans are running well away from any critical speeds, vibration levels should not significantly change due to any small load/speed changes, but it is important to note that the limits given are for the maximum speed of the fan in cases where the speed is variable. If the maximum speed cannot be attained within the vibration limits, it may indicate the presence of a serious problem which should be investigated.

Some diagnostic guidelines, which are given in Annex C, have been based on previous experience and are intended to be used in logical progression to investigate a fault.

Evaluation zone boundaries as given in ISO 10816-1 may be used to permit a qualitative assessment of the vibration of a given fan and provide guidelines for future action.

It should be expected that the vibration level of new fans will be less than the limits given in Tables 3, 4 and 5. These correspond to Zone A limits when applicable. The recommended limits for alarms and shutdown have been based on historical information for the particular types of fan.

## **Annex H**

(informative)

### **Suggested relaxation of specified grades and levels**

It is recognized that it would be unnecessary for a manufacturer to accurately balance an impeller for a client who would accept a lower quality of balance and vibration. Although not within the scope of this International Standard, higher values could be used by agreement between the manufacturer and the client. It is suggested that the permissible balance levels be those in Table 4, increased by a factor of 2,4, and the vibration levels be those in Table 5, increased by a factor of 1,6.

## Bibliography

- [1] ISO 1925:2001, *Mechanical vibration — Balancing — Vocabulary*
- [2] ISO 2041:1990, *Vibration and shock — Vocabulary*
- [3] ISO 2953:1985, *Balancing machines — Description and evaluation*
- [4] ISO 2954:1975, *Mechanical vibration of rotating and reciprocating machinery — Requirements for instruments for measuring vibration severity*
- [5] ISO 5802, *Industrial fans — Performance testing in situ*
- [6] ISO 8821:1989, *Mechanical vibration — Balancing — Shaft and fitment key convention*
- [7] ISO 7919-1:1996, *Mechanical vibration of non-reciprocating machines — Measurement on rotating shafts and evaluation criteria — Part 1: General guidelines*
- [8] ISO 10816-1:1995, *Mechanical vibration — Evaluation of machine vibration by measurements on non-rotating parts — Part 1: General guidelines*
- [9] ISO 11342:1998, *Mechanical vibration — Methods and criteria for the mechanical balancing of flexible rotors*
- [10] ISO 12499, *Industrial fans — Mechanical safety of fans — Guarding*
- [11] ISO 13347 (all parts), *Industrial fans — Determination of fan sound power level under standardized laboratory conditions*
- [12] ISO 13349, *Industrial fans — Vocabulary and definitions of categories*
- [13] ISO 13350, *Industrial fans — Performance testing of jet fans*
- [14] ISO 13351, *Industrial fans — Dimensions*
- [15] IEC 60034-14:1996, *Rotating electrical machines — Part 14: Mechanical vibration of certain machines with shaft heights 56 mm and higher — Measurement, evaluation and limits of vibration*
- [16] ANSI/AMCA 204-96, *Balance Quality and Vibration Levels for Fans*
- [17] Professor JANS TRAMPE BROCH, *Mechanical Vibration and Shock Measurements* Bruel & Kjaer Ltd 1972
- [18] RANDALL R.B., *Frequency Analysis*, Bruel & Kjaer Ltd 1977
- [19] *Advanced Audio — Visual Customer Training Instruction Manual — IRD Mechanical Ltd*
- [20] Paper 1064-82, *Routine Vibration Testing of Fans*, W.T.W. Cory, Air Movement & Control Association Inc.
- [21] Paper 2839-96 - AMCA Standard 204, *Balance Quality and Vibration Levels for Fans*, H. Leslie Gutzwiller Air Movement & Control Association International
- [22] CORY, W.T.W., *Overview of condition monitoring methods with emphasis on industrial fans — Proceedings of the Institution of Mechanical Engineers Vol. 205, 1991*

- [23] AMCA Publication 202, *Trouble shooting*
- [24] CEN/BTS 2/AH 17<sup>3)</sup> *Industrial Fans — Safety requirement*

---

3) To be published.

---

---

## **BSI — British Standards Institution**

BSI is the independent national body responsible for preparing British Standards. It presents the UK view on standards in Europe and at the international level. It is incorporated by Royal Charter.

### **Revisions**

British Standards are updated by amendment or revision. Users of British Standards should make sure that they possess the latest amendments or editions.

It is the constant aim of BSI to improve the quality of our products and services. We would be grateful if anyone finding an inaccuracy or ambiguity while using this British Standard would inform the Secretary of the technical committee responsible, the identity of which can be found on the inside front cover.  
Tel: +44 (0)20 8996 9000. Fax: +44 (0)20 8996 7400.

BSI offers members an individual updating service called PLUS which ensures that subscribers automatically receive the latest editions of standards.

### **Buying standards**

Orders for all BSI, international and foreign standards publications should be addressed to Customer Services. Tel: +44 (0)20 8996 9001.  
Fax: +44 (0)20 8996 7001. Email: [orders@bsi-global.com](mailto:orders@bsi-global.com). Standards are also available from the BSI website at <http://www.bsi-global.com>.

In response to orders for international standards, it is BSI policy to supply the BSI implementation of those that have been published as British Standards, unless otherwise requested.

### **Information on standards**

BSI provides a wide range of information on national, European and international standards through its Library and its Technical Help to Exporters Service. Various BSI electronic information services are also available which give details on all its products and services. Contact the Information Centre.  
Tel: +44 (0)20 8996 7111. Fax: +44 (0)20 8996 7048. Email: [info@bsi-global.com](mailto:info@bsi-global.com).

Subscribing members of BSI are kept up to date with standards developments and receive substantial discounts on the purchase price of standards. For details of these and other benefits contact Membership Administration.  
Tel: +44 (0)20 8996 7002. Fax: +44 (0)20 8996 7001.  
Email: [membership@bsi-global.com](mailto:membership@bsi-global.com).

Information regarding online access to British Standards via British Standards Online can be found at <http://www.bsi-global.com/bsonline>.

Further information about BSI is available on the BSI website at <http://www.bsi-global.com>.

### **Copyright**

Copyright subsists in all BSI publications. BSI also holds the copyright, in the UK, of the publications of the international standardization bodies. Except as permitted under the Copyright, Designs and Patents Act 1988 no extract may be reproduced, stored in a retrieval system or transmitted in any form or by any means – electronic, photocopying, recording or otherwise – without prior written permission from BSI.

This does not preclude the free use, in the course of implementing the standard, of necessary details such as symbols, and size, type or grade designations. If these details are to be used for any other purpose than implementation then the prior written permission of BSI must be obtained.

Details and advice can be obtained from the Copyright & Licensing Manager.  
Tel: +44 (0)20 8996 7070. Fax: +44 (0)20 8996 7553.  
Email: [copyright@bsi-global.com](mailto:copyright@bsi-global.com).