

CONFIRMED
DECEMBER 2007

Methods for

Analysis and testing of coal and coke —

Part 108: Tests special to coke —

Section 108.2 Determination of Micum
and Irsid indices

Committees responsible for this British Standard

The preparation of this British Standard was entrusted by the Solid Mineral Fuels Standards Policy Committee (SFC/-) to Technical Committee SFC/3, upon which the following bodies were represented:

British Cement Association
 British Coal Corporation
 British Gas plc
 British Steel Industry
 Electricity Industry in United Kingdom
 GAMBICA (BEAMA Ltd.)
 Institute of British Foundrymen
 Institute of Petroleum
 Power Generation Contractors' Association (BEAMA Ltd.)

This British Standard, having been prepared under the direction of the Solid Mineral Fuels Standards Policy Committee, was published under the authority of the Standards Board and comes into effect on 31 January 1992

© BSI 08-1999

The following BSI references relate to the work on this standard:
 Committee reference SFC/3
 Draft for comment 90/56254 DC

ISBN 0 580 20176 7

Amendments issued since publication

Amd. No.	Date	Comments

Contents

	Page
Committees responsible	Inside front cover
Foreword	ii
1 Scope	1
2 Definitions	1
3 Principle	1
4 Apparatus	1
5 Sampling and size analysis	3
6 Preparation of test portion	3
7 Procedure	3
8 Expression of results	4
9 Precision	4
10 Test report	4
Figure 1 — Cylindrical steel drum and tray	2
Table 1 — Precision	4
Publication(s) referred to	Inside back cover

Foreword

This Section of BS 1016 has been prepared under the direction of the Solid Mineral Fuels Standards Policy Committee. Part 108 is a revision of the 1980 edition of BS 1016-13, which will be withdrawn when Sections 108.5 and 108.6 are published. This Section replaces 4.3 of BS 1016-13:1980, from which the principal changes are as follows.

- a) The test sample is now dried, if necessary, so that its moisture content is lower than 5 % (*m/m*).
- b) The sieving of the test portion after rotation in the drum is now carried out using only those test sieves corresponding to the indices to be determined.
- c) The Irsid test is now specified as a separate test involving 500 continuous revolutions of the drum, instead of being an additional test involving a further 400 revolutions after a Micum test (100 revolutions) has been completed.

Part 108 is a further Part numbered under a scheme for rationalizing and restructuring BS 1016. The new series, when complete, will begin with Part 100, which will include a general introduction. The earlier series of Parts is as follows, with the new Part numbers (which will be given to revisions when they are published) in parentheses.

- *Part 1: Total moisture of coal* (Part 101);
- *Part 2: Total moisture of coke* (Part 102);
- *Part 5: Gross calorific value of coal and coke* (Part 105);
- *Part 6: Ultimate analysis of coal* (Part 106);
- *Part 7: Ultimate analysis of coke* (Part 106);
- *Part 8: Chlorine in coal and coke* (Part 106);
- *Part 9: Phosphorus in coal and coke* (Part 106);
- *Part 10: Arsenic in coal and coke* (Part 106);
- *Part 11: Forms of sulphur in coal* (Part 106);
- *Part 14: Analysis of coal ash and coke ash* (Part 114);
- *Part 15: Fusibility of coal ash and coke ash* (Part 113);
- *Part 16: Methods for reporting results* (Part 100);
- *Part 17: Size analysis of coal* (Part 109);
- *Part 18: Size analysis of coke* (Part 110);
- *Part 20: Determination of Hardgrove grindability index of hard coal* (Part 112);
- *Part 21: Determination of moisture-holding capacity of hard coal* (Part 103).

The following Parts in the new series have been published or are in preparation.

- *Part 104: Proximate analysis;*
- *Part 107: Caking and swelling properties of coal;*
- *Part 108: Tests special to coke;*
- *Part 111: Determination of abrasion index of coal.*

Part 108 is divided into six Sections as follows.

- *Section 108.1: Determination of shatter indices;*
- *Section 108.2: Determination of Micum and Irsid indices;*
- *Section 108.3: Determination of bulk density (small container);*
- *Section 108.4: Determination of bulk density (large container);*
- *Section 108.5: Determination of density and porosity¹⁾;*
- *Section 108.6: Determination of critical air blast¹⁾.*

¹⁾ In preparation.

This Section is related to ISO 556:1980, published by the International Organization for Standardization (ISO). The principal differences are as follows.

- 1) ISO 556 also describes tests using a larger drum (the “full-Micum drum”).
- 2) ISO 556 recommends the use of certain test sieves with aperture sizes which are different from those specified in this Section of BS 1016.
- 3) ISO 556 specifies a full size analysis of the test portion after rotation in the drum, instead of using only those test sieves corresponding to the indices to be determined.
- 4) ISO 556 describes the Irsid test as an additional test involving a further 400 revolutions of the drum after a Micum test (100 revolutions) has been completed, instead of being a separate test involving 500 continuous revolutions.

WARNING NOTE. This British Standard does not necessarily detail all the precautions necessary to comply with the requirements of the Health and Safety at Work etc. Act 1974 or the Control of Substances Hazardous to Health Regulations 1988. Attention should be paid to any appropriate precautions and the method should be operated only by trained personnel.

A British Standard does not purport to include all the necessary provisions of a contract. Users of British Standards are responsible for their correct application.

Compliance with a British Standard does not of itself confer immunity from legal obligations.

Summary of pages

This document comprises a front cover, an inside front cover, pages i to iv, pages 1 to 4, an inside back cover and a back cover.

This standard has been updated (see copyright date) and may have had amendments incorporated. This will be indicated in the amendment table on the inside front cover.

1 Scope

This Section of BS 1016 describes methods for determining the strength of coke by the Micum and Irsid tests. It is applicable to coke having a nominal top size greater than 20 mm.

NOTE The titles of the publications referred to in this standard are listed on the inside back cover.

2 Definitions

For the purposes of this Section of BS 1016 the following definitions apply.

2.1

micum indices

the percentages of a specially prepared sample of coke remaining on a test sieve of 40 mm nominal size of openings (nominal aperture size) (round hole) and passing a test sieve of 10 mm nominal size of openings (round hole), denoted by M_{40} and M_{10} respectively, after the sample has been subjected to 100 revolutions by a specified procedure in a rotating drum

NOTE Other indices, e.g. M_{60} , M_{20} , may be reported if required.

2.2

irsid indices

the percentages of a specially prepared sample of coke remaining on a test sieve of 40 mm nominal size of openings (nominal aperture size) (round hole) and passing a test sieve of 10 mm nominal size of openings (round hole), denoted by I_{40} and I_{10} respectively, after the sample has been subjected to 500 revolutions by a specified procedure in a rotating drum

NOTE Other indices, e.g. I_{20} , may be reported in addition to, or in place of, I_{40} if required.

3 Principle

A test portion taken from the coke above 20 mm particle size and of known size distribution is subjected to mechanical stresses in a rotating drum for 100 revolutions (Micum test) or 500 revolutions (Irsid test). The mass of coke which is then retained on each of two or more test sieves of different aperture sizes is determined.

4 Apparatus

4.1 Cylindrical steel drum, having the following dimensions (see Figure 1).

Internal length: 500 ± 2 mm

Internal diameter: $1\ 000 \pm 5$ mm

The drum shall be made of 10 mm steel plate. Except for the lifting flights, the internal curved surface of the drum shall be smooth and uninterrupted.

NOTE 1 The drum should preferably be of welded construction and should be replaced if the wall thickness is reduced to less than 5 mm due to wear.

Four lifting flights, each 500 mm long, made of 100 mm by 50 mm by 10 mm thick steel angle, shall be welded or bolted to the full length of the internal curved surface of the drum, parallel to the axis of the drum and spaced at 90° intervals so as to divide the periphery into four equal arcs. The narrower flange of each lifting flight shall be in contact with the curved surface and shall point in the direction opposite to that of the driven rotation of the drum.

NOTE 2 The lifting flights should be replaced when the wider flanges have worn down to 95 mm.

The drum shall have an opening, not less than 500 mm wide, in the curved surface along its full length. This opening shall be fitted with a cover, the inner portion of which shall be made of 10 mm steel plate, of the same curvature as the drum and of the same size as the opening, so that when the cover is in position the inside face shall be approximately flush with the internal surface of the drum.

The cover shall have an outer framework of 50 mm by 10 mm steel strip, overlapping the inner portion by 25 mm all round. It shall be possible to fasten the cover securely by four bolts through holes at the corners of the outer framework. Housing for the bolts shall be provided by a strip of steel, 28 mm by 16 mm, welded to each end plate of the drum. The outer framework of the cover shall be fitted with two handles and also with a sponge rubber gasket, to form a dustproof seal when the cover is in position. The additional mass due to the framework, handles etc. shall be balanced by a plate welded on the outside of the opposite arc of the drum.

The drum shall be fitted with two stub axles which shall be not less than 50 mm in diameter and not less than 250 mm in length, mounted on bearings to give a clearance of 230 mm to 300 mm below the drum to allow the removal of the coke from the drum. To facilitate emptying, it shall be possible to rotate the drum in either direction by hand. The drum shall be capable of being driven at 25 ± 1 r/min (a rotational frequency of 0.417 ± 0.017 Hz) by suitable pulleys or gearing. A revolution counter shall be connected to the drum.

NOTE 3 The revolution counter may also be connected to the motor so that the latter is automatically switched off after 100 or 500 revolutions.

4.2 Tray, approximately 1 500 mm by 600 mm by 150 mm deep, made of a suitable abrasion- and wear-resistant material, for receiving the coke on discharge. The wall at one end shall be inclined at 45° to facilitate emptying.

NOTE Galvanized sheet, 1.22 mm thick, is a suitable material for the tray.

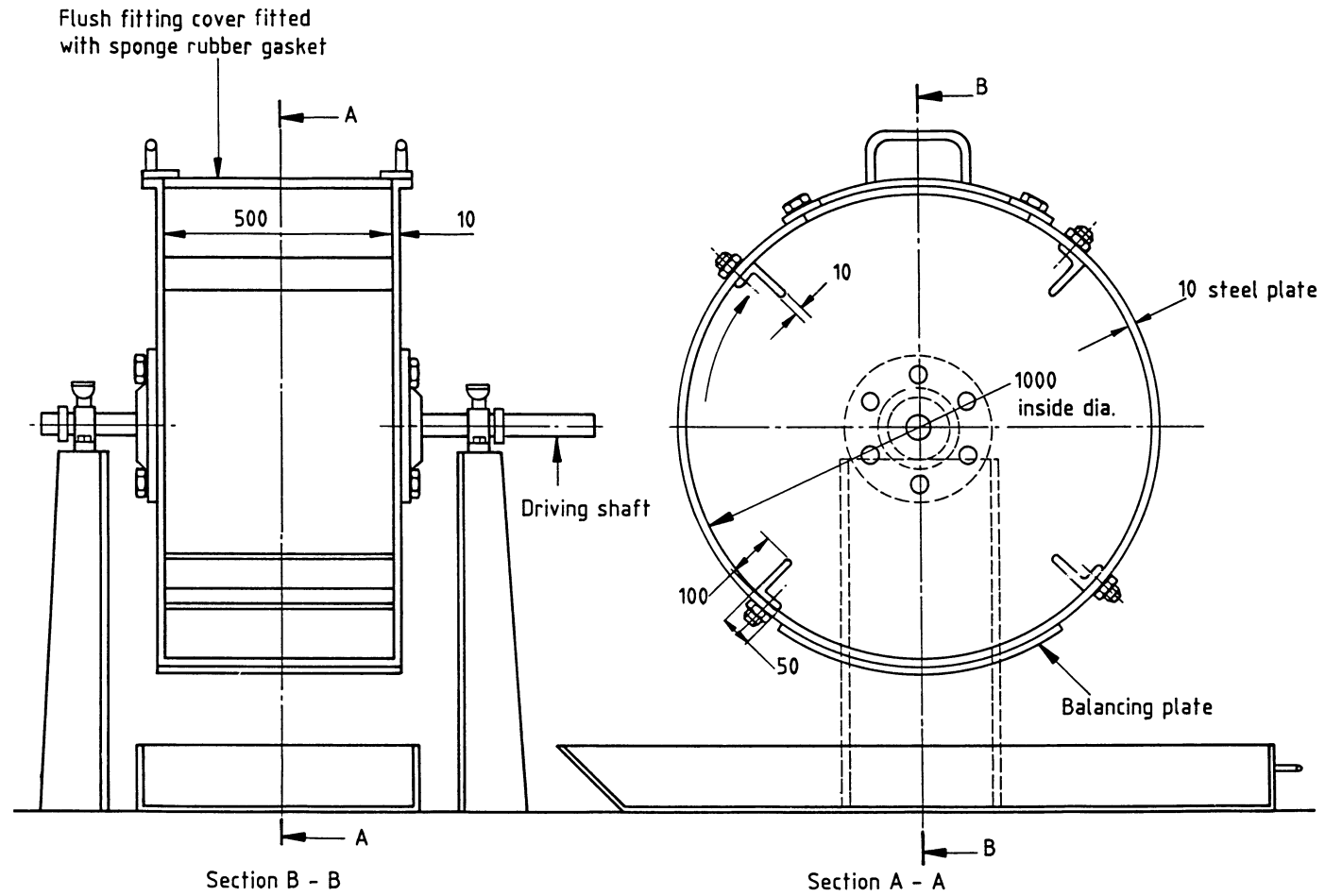

All dimensions are in millimetres.

Figure 1 — Cylindrical steel drum and tray

4.3 Test sieves, of perforated plate, round hole, complying with BS 410 and of nominal aperture sizes 200, 180, 160, 140, 120, 100, 80, 60, 50, 40, 30, 20 and 10 mm. The sieve plates shall be 600 mm square and shall be mounted in hardwood frames armoured with angle plates to reduce wear. When the wear on any aperture exceeds 2 % of its nominal size, the aperture shall be blanked off or the test sieve changed.

NOTE For the larger sizes of foundry coke, ring gauges may be used instead of test sieves.

4.4 Weighing machine, with a capacity of not less than 25 kg, capable of weighing to the nearest 10 g.

5 Sampling and size analysis

Take two gross samples for physical testing in accordance with BS 1017-2. Prepare one of these samples for the determination of moisture content in accordance with BS 1017-2 and carry out the determination in accordance with BS 1016-2. If the moisture content is higher than 5 % (*m/m*), dry the other sample sufficiently to reduce the moisture content to lower than 5 % (*m/m*). Use this second sample for the remainder of the test.

Carry out a size analysis on the sample using a set of test sieves (4.3) of successive aperture size, the largest aperture size being that on which not more than 5 % (*m/m*) of the sample remains. Hand-place the coke on the sieves of aperture size down to and including 40 mm. For the smaller aperture sizes, carry out sieving by hand-shaking. If the quantity of coke remaining on a sieve after 100 movements is such that it would cover more than 75 % of the sieve area, divide it into two or more portions and hand-shake each portion separately.

Weigh each size fraction, to the nearest 10 g, using the weighing machine (4.4) and place each fraction in a separate pile or container. Record the masses retained on the individual sieves as cumulative percentages.

6 Preparation of test portion

Constitute a 25.0 ± 0.1 kg test portion containing all fractions of coke greater than 20 mm in size in approximately the same proportions as they are present in the gross sample. Prepare the test portion by taking at random from each of the separate size fractions of coke (see clause 5), down to and including the 20 mm to 30 mm fraction, an appropriate mass, weighed to the nearest 10 g using the weighing machine (4.4).

NOTE 1 The simplest way of achieving this is to calculate the cumulative mass of coke required in each of these size fractions in the test portion, so as to correspond to the proportions in the gross sample. Then, starting with the fraction with the largest particle size, select pieces of coke and place them in a weighed container until the required cumulative mass for each size fraction has been obtained.

NOTE 2 When testing larger sizes of coke it is recommended that the test portion be constituted from all size fractions of coke greater than 60 mm in size.

7 Procedure

7.1 Micum test (100 revolutions)

7.1.1 Determination

Transfer the test portion (see clause 6) into the clean and empty drum (4.1), taking care to minimize breakage of the coke. Secure the cover on the drum. Rotate the drum at a constant 25 ± 1 r/min (a rotational frequency of 0.417 ± 0.017 Hz) for 100 revolutions. Allow the dust to settle for 1 min, remove the cover and empty the contents of the drum into the tray (4.2). Using the test sieves (4.3) corresponding to the indices to be determined, sieve all the contents of the tray by hand-placing the coke on the sieves of aperture size down to and including 40 mm and by hand-shaking for the smaller aperture sizes.

NOTE Mechanical sieving may be used for size fractions with a maximum particle size of less than 40 mm if it can be demonstrated that the result of the sieving will be the same as that achieved by hand sieving.

Cumulatively weigh the size fractions, to the nearest 10 g, using the weighing machine (4.4), noting the mass corresponding to each size.

7.1.2 Validity of determination

For the determination to be valid, the total mass of the size fractions (see 7.1.1) shall not differ from the original mass of the test portion by more than 150 g. If the difference exceeds this limit, repeat the determination.

7.2 Irsid test (500 revolutions)

7.2.1 Determination

Carry out the test as described in 7.1.1 but rotate the drum at a constant 25 ± 1 r/min for 500 revolutions (instead of 100 revolutions).

7.2.2 Validity of determination

For the determination to be valid, the total mass of the size fractions (see 7.2.1) shall not differ from the original mass of the test portion by more than 250 g. If the difference exceeds this limit, repeat the determination.

8 Expression of results

8.1 Micum test

The Micum index M_{10} is given by the following equation:

$$M_{10} = \frac{(m_1 + m_2)}{m_3} \times 100$$

where

m_1 is the mass of coke (after rotation in the drum) passing the sieve of aperture size 10 mm;

m_2 is the mass of material lost during the determination;

m_3 is the mass of the test portion.

The Micum index M_x , corresponding to a sieve of aperture size x mm, is given by the following equation:

$$M_x = \frac{m_4}{m_3} \times 100$$

where

m_3 is the mass of the test portion;

m_4 is the cumulative mass of coke (after rotation in the drum) retained on all sieves of aperture size equal to or greater than x mm.

Report the results to the nearest 0.1 unit.

8.2 Irsid test

Calculate the Irsid index I_{10} from the same equation given for M_{10} in 8.1. Similarly, calculate other Irsid indices from the equation given for M_x in 8.1.

Report the results to the nearest 0.1 unit.

9 Precision

9.1 General

The precision of the tests can vary considerably depending on the index determined and the actual strength of the coke. The values for repeatability quoted in 9.2 are given only as examples.

9.2 Repeatability

The results of duplicate determinations, carried out at different times in the same laboratory by the same operator with the same apparatus on representative portions constituted from the size fractions of the same gross sample, should not differ by more than the values given in Table 1.

Table 1 — Precision

Index	Repeatability (units)	Reproducibility
M_{40}	5.0	See 9.3
M_{10}	1.5	See 9.3
I_{40}	7.0	See 9.3
I_{10}	7.0	See 9.3

9.3 Reproducibility

No value for reproducibility can be quoted for determinations carried out in different laboratories since the transport of coke samples involves the risk of breakage and thus alteration of the size distribution and the Micum and Irsid indices.

10 Test report

The test report shall include the following:

- a complete identification of the sample;
- the reference to the method used, i.e. BS 1016-108.2:1992;
- the minimum particle size of the smallest size fraction used to prepare the test portion if greater than 20 mm (see note 2 to clause 6);
- the results expressed in accordance with clause 8;
- any unusual features noted during the determination;
- any operation not included in this standard, or regarded as optional.

Publication(s) referred to

BS 410, *Specification for test sieves.*

BS 1016, *Methods for analysis and testing of coal and coke.*

BS 1016-2, *Total moisture of coke.*

BS 1017, *Methods for sampling of coal and coke.*

BS 1017-2, *Sampling of coke.*

ISO 556, *Coke (greater than 20 mm in size) — Determination of mechanical strength²⁾.*

²⁾ Referred to in the foreword only.

BSI — British Standards Institution

BSI is the independent national body responsible for preparing British Standards. It presents the UK view on standards in Europe and at the international level. It is incorporated by Royal Charter.

Revisions

British Standards are updated by amendment or revision. Users of British Standards should make sure that they possess the latest amendments or editions.

It is the constant aim of BSI to improve the quality of our products and services. We would be grateful if anyone finding an inaccuracy or ambiguity while using this British Standard would inform the Secretary of the technical committee responsible, the identity of which can be found on the inside front cover. Tel: 020 8996 9000. Fax: 020 8996 7400.

BSI offers members an individual updating service called PLUS which ensures that subscribers automatically receive the latest editions of standards.

Buying standards

Orders for all BSI, international and foreign standards publications should be addressed to Customer Services. Tel: 020 8996 9001. Fax: 020 8996 7001.

In response to orders for international standards, it is BSI policy to supply the BSI implementation of those that have been published as British Standards, unless otherwise requested.

Information on standards

BSI provides a wide range of information on national, European and international standards through its Library and its Technical Help to Exporters Service. Various BSI electronic information services are also available which give details on all its products and services. Contact the Information Centre. Tel: 020 8996 7111. Fax: 020 8996 7048.

Subscribing members of BSI are kept up to date with standards developments and receive substantial discounts on the purchase price of standards. For details of these and other benefits contact Membership Administration. Tel: 020 8996 7002. Fax: 020 8996 7001.

Copyright

Copyright subsists in all BSI publications. BSI also holds the copyright, in the UK, of the publications of the international standardization bodies. Except as permitted under the Copyright, Designs and Patents Act 1988 no extract may be reproduced, stored in a retrieval system or transmitted in any form or by any means – electronic, photocopying, recording or otherwise – without prior written permission from BSI.

This does not preclude the free use, in the course of implementing the standard, of necessary details such as symbols, and size, type or grade designations. If these details are to be used for any other purpose than implementation then the prior written permission of BSI must be obtained.

If permission is granted, the terms may include royalty payments or a licensing agreement. Details and advice can be obtained from the Copyright Manager. Tel: 020 8996 7070.