

13 A plugs, socket-outlets, adaptors and connection units —

Part 1: Specification for rewirable and non-rewirable 13 A fused plugs

ICS 29.120.30

Committees responsible for this British Standard

The preparation of this British Standard was entrusted by the Power Electrical Engineering Standards Policy Committee (PEL/-) to Technical Committee PEL/23, upon which the following bodies were represented:

ASTA Certification Services
 Association of Consulting Engineers
 Association of Control Manufacturers [TACMA (BEAMA Ltd.)]
 Association of Manufacturers of Domestic Electrical Appliances
 British Electrical Systems Association (BEAMA Ltd.)
 British Electrotechnical Approvals Board
 British Plastics Federation
 Consumer Policy Committee of BSI
 Department of Health
 Department of Trade and Industry (Consumer Safety Unit, CA Division)
 BEAMA Installation
 Electricity Association
 Electronic Components Industry Federation
 Institution of Electrical Engineers
 Lighting Association
 Lighting Industry Federation Ltd.
 National Inspection Council for Electrical Installation Contracting

The following bodies were also represented in the drafting of the standard, through subcommittees and panels:

British Cable Makers' Confederation
 British Radio and Electronic Equipment Manufacturers' Association
 Consumers' Association
 ERA Technology Ltd.
 Institute of Trading Standards Administration
 Institution of Incorporated Executive Engineers
 National Standards Authority of Ireland
 Royal Society for the Prevention of Accidents

This British Standard, having been prepared under the direction of the Power Electrical Engineering Standards Policy Committee, was published under the authority of the Standards Board and comes into effect on 15 February 1995

© The British Standards Institution 2012
 Published by BSI Standards Limited 2012

First published as BS 1363, September 1967
 Second edition, August 1984
 Third edition as Part 1, February 1995

The following BSI references relate to the work on this British Standard:
 Committee reference PEL/23
 Drafts for comment
 88/30090 DC
 11/30203492 DC

Amendments issued since publication

Amd. No.	Date	Comments
9541	July 1997	
14539	9 October 2003	
17435	30 November 2007	See Foreword.
A4	31 May 2012	See Foreword.
C1	30 November 2012	See Foreword.

Contents

	Page
Committees responsible	Inside front cover
Foreword	iii
<hr/>	
1 Scope	1
2 Conditions of use	1
3 Terms and definitions	1
4 General	5
5 General conditions for type testing	5
6 Classification	6
7 Marking and labelling	6
8 Clearances, creepage distances and solid insulation	8
9 Accessibility of live parts	11
10 Provision for earthing	12
11 Terminals and terminations	13
12 Construction of plugs	15
13 <i>(Not used)</i>	22
14 Resistance to ageing and to humidity	22
15 Insulation resistance and electric strength	23
16 Temperature rise	23
17 Breaking capacity of switches incorporated in fused plugs	25
18 Normal operation of switches	25
19 Connection of flexible cords and cord anchorage	25
20 Mechanical strength	27
21 Screws, current-carrying parts and connections	28
22 Resistance to heat	29
23 Resistance to abnormal heat, fire and tracking	29
24 Resistance to excessive residual stresses and to rusting	30
25 Electrical and thermal stress on clamp type (screwless) terminals	31
26 Overload tests	31
<hr/>	
Annex A (normative) The construction and calibration of a calibrated link	32
Annex B (normative) Measurement of clearances and creepage distances	33
Annex C (normative) Determination of the Comparative Tracking Index (CTI) and Proof Tracking Index (PTI)	38
Annex D (normative) Relation between rated impulse withstand voltage, rated voltage and Overvoltage Category	38
Annex E (normative) Pollution degree	29
Annex F (normative) Impulse voltage test	39
Annex G (informative) Specific structure of BS EN 50525 and its derivation from British Standards and from HD 21 and HD 22	41
<hr/>	
Figure 1 — Test pin	42
Figure 2a) — Apparatus for mechanical strength test on resilient covers	43
Figure 2b) — Hardwood block for Figure 2a)	44
Figure 4a) — Dimensions and disposition of pins	45
Figure 4b) — Concave shrinkage allowance for ISODs	47
Figure 5 — Gauge for plug pins	49
Figure 6 — Apparatus for testing plug cover fixing screws	50
Figure 7 — Mounting plate	50
Figure 8 — Plug pin deflection test apparatus for resilient plugs	51
Figure 9 — Apparatus for abrasion test on insulating sleeves of plug pins	52

	Page
Figure 10 — Apparatus for pressure test at high temperatures	53
Figure 11 — GO gauge for socket-outlet	54
Figure 17a) — Test apparatus for temperature rise test	55
Figure 17b) — Dummy front plate for temperature rise test	56
Figure 18 — Apparatus for flexing test	57
Figure 19 — Solid link for test on fuse clips	58
Figure 20 — Tumbling barrel	59
Figure 23 — Apparatus for pressure test	60
Figure 24 — <i>Figure deleted</i>	61
Figure 28 — Calibrated link	62
Figure 29 — Calibration of calibrated link	63
Figure 32 — Apparatus for tests on plug pins	64
Figure 33 — Apparatus for torsion test on pins	65
<hr/>	
Table 1 — Schedule of tests	5
Table 2 — Rated current and maximum fuse rating in normal use, and load for flexing and cord grip tests related to size of flexible cord	8
Table 3a — Torque values for screws and nuts	12
Table 3b — Actuator test force	21
Table 4 — Permitted temperature rises	24
Table 5 — <i>Not used</i>	25
Table 6 — Connection of flexible cords	27
Table 7 — Application of glow-wire test	30
Table 8 — Minimum clearances for basic insulation	9
Table 9 — Minimum creepage distances for basic insulation	10
Table 10 — Withstand voltages for insulation types	11
Table B.1 — Minimum values of width X	33
Table D.1 — Rated impulse withstand voltage for plugs energized directly from the low voltage mains	38
Table F.1 — Test voltages for verifying clearances at sea level	40
<hr/>	
List of references	66
<hr/>	

Foreword

This part of BS 1363 is published by BSI Standards Limited, under licence from The British Standards Institution. It has been prepared by Technical Committee PEL/23. This part of BS 1363, together with BS 1363-2:1995, supersedes BS 1363:1984.

BS 1363-1:1995+A4:2012 supersedes BS 1363-1:1995 (incorporating Amendments Nos. 1:1997, 2:2003 and 3:2007), which, however, remains current and will be withdrawn on 31 May 2015.

The start and finish of text introduced or altered by Amendment No. 3 and Amendment No. 4, respectively is indicated in the text by tags $\boxed{A_3}$ $\langle A_3 \rangle$ and $\boxed{A_4}$ $\langle A_4 \rangle$ respectively. Text introduced or altered by Amendment No. 1 and by Amendment No. 2 is not tagged. The start and finish of text introduced or altered by Corrigendum No. 1 is indicated in the text by tags $\boxed{C_1}$ $\langle C_1 \rangle$. Minor editorial corrections are not tagged.

BS 1363 comprises four parts covering the following.

- *Part 1: Rewirable and non-rewirable 13 A fused plugs;*
- *Part 2: Switched and unswitched socket-outlets;*
- *Part 3: Adaptors;*
- *Part 4: 13 A fused connection units: switched and unswitched.*

NOTE In order to prevent confusion with BS 1363:1984, the figure and clause numbers have been retained.

BS 6500, which is called up in this part of BS 1363, has been superseded by BS EN 50525. In the transition period up until 31 December 2012 flexible cords to either standard may be used. After that date all cords have to be to the relevant part of BS EN 50525.

The structure of BS EN 50525 and its derivation from British Standards and HD 21 and HD 22 is set out in BS EN 50525-1:2011, National Annex NA. This is reproduced in Annex G for the convenience of users of this part of BS 1363.

This publication does not purport to include all the necessary provisions of a contract. Users are responsible for its correct application.

Compliance with a British Standard cannot confer immunity from legal obligations.

Attention is drawn to Statutory Instrument 1768, 1994.

Summary of pages

This document comprises a front cover, an inside front cover, pages i to iv, pages 1 to 66, an inside back cover and a back cover.

The BSI copyright notice displayed in this document indicates when the document was last issued.

1 Scope

This part of BS 1363 specifies requirements for 13 A fused plugs having insulating sleeves on line and neutral pins, for household, commercial and light industrial purposes, with particular reference to safety in normal use. The plugs are suitable for the connection of portable appliances, sound-vision equipment, luminaires, etc. in a.c. circuits only, operating at voltages not exceeding 250 V r.m.s. at 50 Hz.

Requirements are specified for plugs incorporating a fuse link complying with BS 1362:1973. The plugs may be rewirable or non-rewirable complete with flexible cord. Two categories of plugs are specified covering normal and rough use. ^{A4} Rewirable plugs are intended for use with flexible cords complying with BS 6500:2000, or equivalent cords to the relevant part of BS EN 50525 (see Annex G), having conductor cross-sectional areas from 0.5 mm² to 1.5 mm² inclusive. ^{A4}

NOTE 1 See 19.1.

Non-rewirable plugs are intended for use with flexible cords having conductor cross-sectional areas not exceeding 1.5 mm².

NOTE 2 See 19.4.

This standard also applies to non-rewirable 13 A plugs which have the brass earth pin replaced with a similarly dimensioned protrusion made of insulating material designated as an insulated shutter opening device (ISOD) designed to operate the shutter mechanism of a socket-outlet conforming to BS 1363-2.

^{A4} Plugs containing devices other than switches and indicator lamps are outside the scope of this part of BS 1363. ^{A4}

^{A3} NOTE 3 Brass can be copper, phosphor-bronze or other metal at least equivalent with regard to its conductivity, resistance to abrasion and resistance to corrosion. ^{A3}

^{A3} NOTE 4 ^{A3} The titles of the publications referred to in this part of BS 1363 are listed on the inside back cover

^{A3} NOTE 5 ^{A3} In order to maintain safety and interchangeability with plugs and socket-outlets it is necessary that these products comply with the requirements of Clause 9, 12 and 13 of this part of BS 1363, however their body outline need not be limited at a distance of 6.35 mm from the plug engagement ^{A3} surface. ^{A3}

^{A3} NOTE 6 ^{A3} Requirements for electromagnetic compatibility are not given for the following reasons.

A plug does not emit intolerable electromagnetic interference since significant electromagnetic disturbances are only generated during insertion and withdrawal which are not continuous.

A plug is mechanical by nature of construction. The product is therefore immune from electromagnetic interference.

2 Conditions of use

Plugs shall be suitable for use under the following conditions:

- a) an ambient temperature in the range $-5\text{ }^{\circ}\text{C}$ to $+40\text{ }^{\circ}\text{C}$, the average value over 24 h not exceeding $25\text{ }^{\circ}\text{C}$;

NOTE Under normal conditions of use, the available cooling air is subject to natural atmospheric variations of temperature and hence the peak temperature occurs only occasionally during the hot season, and on those days when it does occur it does not persist for lengthy periods.

- b) a situation not subject to exposure to direct radiation from the sun or other source of heat likely to raise temperatures above the limits specified in a);

- c) an altitude not exceeding 2 000 m above sea level;

- d) an atmosphere not subject to abnormal pollution by smoke, chemical fumes, rain, spray, prolonged periods of high humidity or other abnormal conditions. This is equivalent to pollution degree 2, see Annex E, and overvoltage category III, see Annex D.

3 Terms and definitions

For the purposes of this part of BS 1363 the following definitions apply.

NOTE Where the terms voltage and current are used, they imply r.m.s. values, unless otherwise stated.

3.1 plug

a portable fused device having projecting pins designed to engage with the contacts of a corresponding socket-outlet. A plug also incorporates means for the electrical connection and the mechanical retention of a suitable flexible cord

3.2

rough-use plug

a plug designed to withstand severe mechanical handling

NOTE Rough-use plugs are identified by additional marking in accordance with 7.1c). They are not intended for gross misuse. For instance, a plug should not be withdrawn from a socket-outlet by pulling on the attached flexible cord.

3.3

rewirable plug

a plug so constructed that a flexible cord can be fitted or replaced using general purpose tools

3.4

non-rewirable plug

A4 a plug so constructed that it forms a complete unit with the flexible cord which cannot be replaced after assembly by the manufacturer of the plug **A4**

NOTE See also 12.6.

3.5

moulded-on plug

a non-rewirable plug, the manufacture of which is completed by insulating material moulded around pre-assembled component parts and the terminations of the flexible cord

3.6

fused plug

a plug having provision for a replaceable cartridge fuse link

3.7

terminal

a means by which the user can make an electrical connection between the appropriate flexible cord and the conducting parts of the plug without the use of special purpose tools

3.8

screw-type terminal

a terminal in which the connection is made directly by means of screws or nuts of any kind or indirectly through an intermediate metal part such as a washer, clamping plate or anti-spread device on which the screw bears directly

NOTE The following are examples of screw-type terminals.

- a) A pillar terminal is a terminal in which the conductor is inserted into a hole or cavity, where it is clamped under the shank of the screw or screws.
- b) A screw terminal is a terminal in which the conductor is clamped under the head of the screw.
- c) A stud terminal is a terminal in which the conductor is clamped under a nut.

3.9

clamp type (screwless) terminal

a terminal in which the connection is made by clamping the conductor of a flexible cord between two metallic surfaces without the use of a screw

3.10

termination

a means by which an electrical connection can be made between the appropriate flexible cord and the conducting part of the plug using special purpose tools, e.g. soldering, welding, crimping

3.11

fuse carrier

a movable or removable part designed to carry, retain, cover and/or remove the fuse link

3.12

type test

a test or series of tests made on a type test sample, for the purpose of checking compliance of the design of a given product with the requirements of the relevant standard

3.13**type test sample**

a sample consisting of one or more similar units or specimens submitted by the manufacturer or responsible vendor for the purpose of a type test

3.14**accessible external surfaces of a plug**

all surfaces which can be touched by test probe B of BS EN 61032:1998 when the plug is in full engagement with a corresponding socket-outlet

3.15**engagement surface of a plug**

that surface which cannot be touched by test probe B of BS EN 61032:1998 when the plug is in full engagement with a corresponding socket-outlet

3.16**live parts**

current-carrying parts and those metal parts in contact with them during normal use

NOTE Metal parts of the earthing circuit are not considered to be current-carrying parts.

3.17**fine wire thermocouple**

a thermocouple having wires not exceeding 0.3 mm in diameter

3.18**calibrated link**

a calibrated heat source for use in place of a fuse link during temperature rise tests

3.19**indicator lamp (pilot lamp)**

a lamp A_3 or similar device A_3 which illuminates to indicate that the plug is energized

3.20**resilient material**

a material having the inherent capability of regaining or substantially regaining its original form when deforming loads are removed

3.21**creepage distance**

shortest distance along the surface of the insulating material between two conductive parts

3.22**clearance**

shortest distance in air between two conductive parts

3.23**Insulated Shutter Opening Device (ISOD)**

protrusion from the engagement surface of the plug, in place of a brass earth pin, made of insulating material having dimensions similar to those of a brass earth pin

3.24**basic insulation**

insulation applied to live parts to provide basic protection against electric shock

NOTE Basic insulation does not necessarily include insulation used exclusively for functional purposes.

3.25**supplementary insulation**

independent insulation applied in addition to basic insulation, in order to provide protection against electric shock in the event of failure of basic insulation

3.26**reinforced insulation**

single insulation system applied to live parts, which provides a degree of protection against electric shock equivalent to double insulation under the conditions specified in the relevant standard

3.27**functional insulation**

insulation between conductive parts which is necessary only for the proper functioning of the equipment

A₃ 3.28**class I**

method of protection against electric shock which does not rely on basic insulation only, but which includes means for the connection of exposed-conductive-parts to a protective conductor in the fixed wiring of the installation **A₃**

A₃ 3.29 A₃**class II**

A₃ method of protection against electric shock which does not rely on basic insulation only, **A₃** but in which additional safety precautions, such as double insulation or reinforced insulation are provided, there being no provision for protective earthing or reliance upon installation conditions

A₃ NOTE 1 Such a method may be one of the following.

- a) Equipment having a double and substantially continuous enclosure of insulation material which envelopes all metal parts with the exception of small parts such as name plates, screws and rivets which are isolated from live parts by insulation at least equivalent to reinforced insulation. Such equipment is called "insulated encased class II equipment".
- b) Equipment having a substantially continuous enclosure of metal, in which double insulation is used throughout, except for those parts where reinforced insulation is used. Such equipment is called "metal encased class II equipment".
- c) Equipment that is a combination of types a) and b) above. **A₃**

NOTE 2 The enclosure of an insulation encased class II appliance may form a part or whole of the supplementary insulation, or reinforced insulation.

NOTE 3 If an appliance with double insulation and/or reinforced insulation throughout has an earthing terminal or an earthing contact, it is of class I construction.

NOTE 4 Class II appliances may have parts in which protection against electric shock relies on operation at safety extra-low voltage (SELV).

A₄ 3.30**insignificant mass**

insufficient combustible mass to constitute a fire hazard

NOTE Parts of insignificant mass are usually less than 2 g. **A₄**

A₄ 3.31**small parts**

parts where each surface lies completely within a circle of 15 mm diameter or where some of the surface lies outside the 15 mm diameter circle but in such a way that it is not possible to place a circle of 8 mm diameter on any of this remaining surface

[BS EN 60695-2-11:2001, 3.1, modified]

NOTE More information concerning small parts can be found in BS EN 60695-2-11:2001, 3.1. **A₄**

A₄ 3.32**switched plug**

a plug with associated switch or switches to disconnect the supply to the line terminal/termination or to both line and neutral terminals/terminations **A₄**

A₄ 3.33**actuating member**

that part which is moved, e.g. pulled, pushed or turned by the user, to operate the switch mechanism of a switched plug **A₄**

4 General

Plugs shall be so designed and constructed that in normal use their performance is reliable and minimizes the risk of danger to the user or to the surroundings. Such plugs shall be capable of meeting all the relevant requirements and tests specified in this part of BS 1363. A_3 Plugs shall not be used for the connection of electrical power generators to socket outlets. A_3

A_4 Throughout this standard, where flexible cords to BS 6500 are referred to these may be replaced by equivalent cords (now referred to as cables) to BS EN 50525 which has superseded BS 6500; when BS 6500 is withdrawn, equivalent cables (cords) to BS EN 50525 shall be used. A_4

5 General conditions for type testing

5.1 All tests shall be type tests.

Unless otherwise specified in this part of BS 1363, the plugs shall be tested as delivered by the manufacturer or responsible vendor and under normal conditions of use, at an ambient temperature of $20\text{ }^\circ\text{C} \pm 5\text{ }^\circ\text{C}$ and after being conditioned at normal laboratory temperature and humidity levels for at least 4 days.

The plugs used for the tests shall be representative of normal production items in respect of all details which may affect the test results.

Non-rewirable plugs shall be supplied with an appropriate flexible cord which shall be at least 1 m long.

Plugs shall be deemed to comply if no specimen fails in the complete series of tests given in Table 1.

Table 1 — Schedule of A_3 tests A_3

Sequence no.	Samples	Test	Clause number
1	3	Inspection, measurement, gauging and manipulation	5, 6, 7, 11.1, 9.1, 9.2, 9.4, 12.1, 12.2, 12.3, 12.4, 12.5, 12.9, (12.9.1, 12.9.2, 12.9.3 and 12.9.6 only), 12.13, 12.14, 12.15, 12.16, 19.2, 19.3, 19.4, 19.6, 21.8 A_3 (except Annex C) A_3
2	3	General	5, 9.3, 19.1, 12.12, 12.17.2, 12.17.3, 12.17.2
3	3		5, 14.2, 12.8, 19.5, 12.17.4
4	3		5, 14.1, 15.1, 16, A_4 17, 12.18.1, 18, A_4 20, 12.7, 10.1, 11.12, 12.10, 12.6, 12.11, 21.3
5	3*		5, A_3 12.9.4.1 or 12.9.4.2 A_3
6	3		5, 14.1, 21.1
7	3	Additional tests for rewirable plugs with clamp type (screwless) terminals	5, 11.10, 11.11
8a)	A_3 9 A_3	Additional tests for plugs with A_4 nickel plated brass pins, A_4 non-solid pins A_3 and/or ISODs A_3	5, 12.9.5
8b)	A_3 3 A_3	Additional tests for plugs fitted with ISOD	5, 12.9.4.3
9	3	Material	5, 22
10	3		5, 23.2, A_3 8.2 (Annex C only) A_3
11	3		5, 24, 21.3
A_4 12	3	Positive break (switched plugs)	5, 12.18.2 A_4
A_4 13	3	Overloads	5, 14.1, 26 A_4

NOTE 1 The order of tests given in sequence no. 1 is preferred but not mandatory except where required within the text of the appropriate clause.

NOTE 2 * denotes that an additional three samples will be required for plugs with non-solid pins.

If one specimen fails in a complete series of tests given in Table 1, then plugs of that type shall be deemed to have failed to comply with this part of BS 1363, unless the plug is shown to be not representative of normal production or design, in which case a further type test sample shall be submitted to the test or tests in that particular group. If there is no failure in this re-test then plugs of that type shall be deemed to comply with this part of BS 1363.

If more than one specimen fails in the complete series of tests given in Table 1 then plugs of that type shall be deemed not to comply with this part of BS 1363.

NOTE 1 For type testing, all tests have been included in the test schedule and should be performed in the specified order. References to carrying out specific tests in various clauses are not intended to indicate a sequence of testing different to that in the schedule and should not be conducted as separate additional tests.

NOTE 2 Where reference to BS 6500:2000 is made equivalent flexible cords to the latest version of that standard may be used.

5.2 All inspections and tests, of any one classification (see Clause 6), shall be carried out as specified in the clauses listed in Table 1 on the number of specimens in the sample column and in the order given.

5.3 Gauges in accordance with Figure 5 shall be considered to comply with the dimensional requirements if the results of the measured values are within the specified dimensions and the uncertainty of measurement at not less than 95 % confidence level does not exceed ± 0.005 mm.

6 Classification

Plugs shall be classified as follows:

- rewirable or non-rewirable;
- for normal use or rough use;
- fitted with screw or clamp type (screwless) terminals;
- for non-rewirable plugs for class II applications only, fitted with A_3 un-terminated brass earth pin A_3 or ISOD.

7 Marking and labelling

7.1 Plugs shall be legibly and durably marked with the following information, which shall not be placed on screws, removable washers or other easily removable parts, or upon parts intended for separate sale:

- a) either the name, trade mark or identification mark of the manufacturer or responsible vendor, which may be duplicated on a removable fuse carrier;
- b) the number of this British Standard, i.e. BS 1363¹⁾;
- c) for rough-use plugs the number of this British Standard shall be followed by “/A”;
- d) on rewirable plugs the terminals intended for the connection of the various conductors shall be identified by the symbols given in 7.5;
- e) the words “FUSE” or “FUSED” or the symbol (as given in 7.5) on the external accessible surface of a plug;
- f) all rewirable plugs shall be marked on the engagement surface with the rated current. All non-rewirable plugs shall be marked with the rated current of the fuse link fitted, which shall not exceed the value given in Table 2 for the appropriate size of flexible cord;
- g) plugs with clamp type (screwless) terminals shall be marked to show the length of conductor insulation to be removed before fitting the conductor in the terminal.

7.1.1 Compliance shall be checked by inspection and by rubbing the marking for approximately 15 s with a cloth soaked in water, and again for approximately 15 s with a cloth soaked in an aliphatic solvent hexane with a content of aromatics of maximum 0.1 % by volume, a Kauri-butanol value of 29, an initial boiling point of approximately 69 °C, and relative density of approximately 0.68. The marking shall remain legible. Markings produced by an engraving or moulding process shall be deemed to comply without test.

¹⁾ Marking BS 1363 on or in relation to a product represents a manufacturer’s declaration of conformity, i.e. a claim by or on behalf of the manufacturer that the product meets the requirements of the standard. The accuracy of the claim is solely the claimant’s responsibility. A_3 Text deleted A_3

7.2 Rewirable plugs shall have a removable tag or label indicating the rating of the fuse link fitted, e.g. "Fitted with "X" ampere fuse" (where "X" denotes the rating of the fuse link).

7.2.1 Compliance shall be checked by inspection.

7.3 Except where a plug fitted with a flexible cord is supplied direct to a manufacturer for incorporation in other equipment, the free end of such an assembly shall have a label attached which shall include the following:

- a) the statement: "The flexible cord of this plug must be connected to a piece of equipment before being plugged into a socket-outlet.";
- b) the maximum rating, in amperes, of the equipment to which it may be fitted (as given in Table 2);
- c) the colour code of the cores of the flexible cord as follows:

"IMPORTANT. Wires in the mains lead are coloured in accordance with the following code:

Green/yellow	Earth (if any)
Blue	Neutral
Brown	Live";

- d) if the plug is fitted with a 2-core flexible cord, the following statement:

"This lead must not be used with equipment requiring the protection of an earth continuity conductor."

7.3.1 Compliance shall be checked by inspection.

7.4 Rewirable plugs shall be provided with adequate instructions for the safe connection of the appropriate flexible cords, including clear instructions for the removal of insulation from the conductors.

Plugs incorporating clamp type (screwless) terminals shall be supplied with information indicating that the plug is fitted with clamp type (screwless) terminals and containing clear instructions for the removal of insulation from the conductors and for the effective connection and disconnection of conductors.

7.4.1 Compliance shall be checked by inspection.

7.5 Symbols shall be as follows:

amperes	A
volts	V
line	L
neutral	N
*earth	\oplus (preferred) or \perp
	The letter "E" may be used in addition to either of these symbols.
*fuse	\equiv

NOTE BS 6217 gives details of symbols marked *.

Table 2 — Rated current and maximum fuse rating in normal use, and load for flexing and cord grip tests related to size of flexible cord

Flex cord nominal cross-sectional area mm ²	Rated current ^d A	Test current ±0.4 A A	Fuse rating A	Load for flexing test +2 %, -0 % kg	Cord grip tests	
					Load +2 % -0 % kg	Torque ^b N·m
0.5	3	3.5	3 (5) ^a	1	3	0.15
0.75	6	7	13	1	3	0.20
1 (0.75) ^c	10	11	13	2	3	0.25
1.25	13	14	13	2	6	0.30
1.5	13	14	13	2	6	0.35

^a The figure in brackets indicates the fuse rating when a non rewirable plug is used with certain types of equipment where the use of a 5 A fuse link is necessary because of the high instantaneous inrush current.

^b The recording of a measured value of torque in accordance with this table is considered to comply with this part of BS 1363 on condition that the uncertainty of measurement at not less than 95 % confidence level does not exceed ±10 %.

^c The figure in brackets indicates the flexible cord size which may be used for cord sets where non-rewirable plugs are used with a maximum flexible cord length of 2 m.

^d Non-rewirable plugs may have a rated current appropriate to a smaller cord size than that fitted. (e.g. a plug rated at 3 A may be fitted with an 0.75 mm cord). In such cases, load and torque parameters for testing shall relate to the size of cord fitted and the test current shall relate to the rated current of the plug.

8 Clearances, creepage distances and solid insulation

Plugs shall be constructed so that the clearances, creepage distances and solid insulation are adequate to withstand the electrical stresses taking into account the environmental influences that may occur. Clearances, creepage distances and solid insulation shall conform to the relevant requirements of 8.1, 8.2 and 8.3. The distance between lead wires in the pinch of a neon lamp with external resistor shall be a minimum of 1 mm.

~~Text deleted~~

Plugs complying with the requirements for basic insulation shall be deemed to meet the requirements of this clause. If the manufacturer declares an insulation level exceeding basic insulation then the plug shall be tested accordingly.

NOTE 1 The requirements and tests are based on BS EN 60664-1.

NOTE 2 Product insulation consists of Basic Insulation and Protective Earthing as required by BS EN 61140 for Class I equipment. Mechanical strength equivalent to that which would be provided by Reinforced Insulation as listed in BS EN 61140 is achieved in BS 1363 products through the specific mechanical and material tests of BS 1363.

8.1 Clearances

Plugs energized directly from the low-voltage supply fall into Overvoltage Category III.

The clearances shall withstand the rated impulse voltage declared by the manufacturer considering the rated voltage and the Overvoltage Category as given in Annex D and the pollution degree declared by the manufacturer in accordance with Annex E.

For the measurements:

— all parts which may be removed without the use of a tool are removed and moveable parts which can be assembled in different orientations are placed in the most unfavourable position.

NOTE Moveable parts are, for example hexagonal nuts, the position of which cannot be controlled throughout an assembly.

~~Text deleted~~

8.1.1 Clearances for basic insulation

The clearances for basic insulation shall not be less than the values given in Table 8 except as described below.

Smaller A_3 unspecified A_3 clearances (except those values marked in Table 8 with Note b) may be used if the plug meets the impulse withstand voltage test of Annex F at the impulse voltage specified in Annex D but only if the parts are rigid or located by mouldings or if the construction is such that it is unlikely that distances will be reduced by distortion or by movement of the parts during mounting, connection and normal use.

Compliance shall be checked by inspection, and if necessary by measurement, or by the test of Annex F.

A_3 If clearance distances are to be measured, this shall be carried out in accordance with Annex B. A_3

8.1.2 Clearances for functional insulation

The clearances for functional insulation shall not be less than the values specified for basic insulation in 8.1.1.

Compliance shall be checked by inspection, and if necessary by measurement, or by the test of Annex F.

A_3 If clearance distances are to be measured, this shall be carried out in accordance with Annex B. A_3

8.1.3 Clearances for supplementary insulation

The clearances for supplementary insulation shall not be less than the values specified for basic insulation in 8.1.1.

Compliance shall be checked by inspection, and if necessary by measurement, or by the test of Annex F.

A_3 If clearance distances are to be measured, this shall be carried out in accordance with Annex B. A_3

Table 8 — Minimum clearances for basic insulation

Rated impulse withstand voltage (KV) ^a	Minimum clearances in air up to 2 000 m above sea level mm
0.33	0.2 ^b
0.50	0.2 ^b
0.80	0.2 ^b
1.5	0.5
2.5	1.5
4.0	3
6.0	5.5

^a See Annex D. This voltage is:

- for functional insulation: the maximum impulse voltage expected to occur across the clearance;
- for basic insulation directly exposed to or significantly influenced by transient overvoltage from the low-voltage mains: the rated impulse withstand voltage of the plug;
- for other basic insulation: the highest impulse voltage that can occur in the circuit.

^b Minimum clearance values are based on BS EN 60664-1.

8.1.4 Clearances for reinforced insulation

The clearances for reinforced insulation shall be not less than the values specified for basic insulation in 8.1.1 but using the next higher step for rated impulse withstand voltage given in Table 8.

A_3 NOTE The requirement is not applicable to the sleeves of the plug pins. A_3

Compliance shall be checked by inspection and measurement, A_3 or by the test of Annex F. A_3

 A_4 8.1.5 Contact gap

The minimum contact gap shall be 1.2 mm in the open position.

Compliance shall be checked by measurement. A_4

8.2 Creepage distances

The creepage distances shall be dimensioned for the voltage, which is expected to occur in normal use taking into account the pollution degree, and the material group as declared by the manufacturer.

For the measurements:

- all parts which may be removed without the use of a tool are removed and movable parts which can be assembled in different orientations are placed in the most unfavourable position.

NOTE 1 Moveable parts are, for example hexagonal nuts, the position of which cannot be controlled throughout an assembly.

NOTE 2 A creepage distance cannot be less than the associated clearance.

Creepage distances are measured in accordance with Annex B.

The relationship between material group and between comparative tracking index (CTI) values and proof tracking index (PTI) values is as follows:

Material group I	$600 \leq \text{CTI/PTI}$
Material group II	$400 \leq \text{CTI/PTI} < 600$
Material group IIIa	$175 \leq \text{CTI/PTI} < 400$
Material group IIIb	$100 \leq \text{CTI/PTI} < 175$

The CTI or PTI values are determined in accordance with Annex C.

NOTE 3 For glass, ceramics and other inorganic materials which do not track, creepage distances need not be greater than their associated clearance.

8.2.1 Creepage distances for basic insulation

The creepage distances for basic insulation shall not be less than the values given in Table 9.

Compliance shall be checked by measurement.

Table 9 — Minimum creepage distances for basic insulation

Rated Voltage ^a V (r.m.s.)	Pollution Degree 2 ^b			Pollution Degree 3 ^b		
	Material group			Material group		
up to and including	I	II	IIIa/IIIb	I	II	IIIa
250	1.3	1.8	2.5	3.2	3.6	4.0

^a This voltage is the voltage rationalized through Table 3a and Table 3b of BS EN 60664-1 based on the rated voltage.
^b Details of pollution degrees are given in Annex E.

8.2.2 Creepage distances for functional insulation

The creepage distances for functional insulation shall not be less than the values specified for basic insulation in 8.2.1.

Compliance shall be checked by measurement.

8.2.3 Creepage distances for supplementary insulation

The creepage distances for supplementary insulation shall not be less than the values specified for basic insulation in 8.2.1.

Compliance shall be checked by measurement.

8.2.4 Creepage distances for reinforced insulation

The creepage distances for reinforced insulation shall not be less than those derived from twice the distance specified for basic insulation in Table 9.

A3 NOTE The requirement is not applicable to the sleeves of the plug pins. **A3**

Compliance shall be checked by measurement.

8.3 Solid insulation

Solid insulation for basic, **A4** functional, **A4** supplementary and reinforced insulation shall be capable of withstanding electrical stresses which can occur in normal use.

No minimum thickness is specified for solid insulation.

8.3.1 Compliance shall be checked by tests in accordance with **15.1.3** using the values given in Table 10.

Text deleted

Table 10 — Withstand voltages for insulation types

Insulation	Test voltage V (r.m.s)
Functional Insulation	1 500
Basic Insulation	1 500
Supplementary Insulation	1 500
Reinforced Insulation	3 000

A3

9 Accessibility of live parts

9.1 Live parts of plugs shall not be accessible when the plugs are wired as in normal use and in full engagement in a corresponding socket-outlet.

Removal of detachable fuse carriers shall not result in live parts becoming accessible when the plug is in full engagement with the socket outlet or the socket outlet portion of an adaptor.

9.1.1 Compliance shall be checked by the application of test probe 12 of BS EN 61032:1998 applied with a force of 5_{-1}^0 N with rewirable plugs fitted with a 2-core flexible cord as given in Table 24 of BS 6500:2000 and non-rewirable plugs as supplied. Detachable fuse carriers shall be removed before this test is undertaken.

9.2 Plugs shall be designed and constructed so as to protect the user against accidental contact with live parts during insertion or withdrawal of plugs.

9.2.1 Compliance shall be proved by satisfying the dimensional and gauging requirements of this Part of BS 1363.

9.3 Resilient covers of plugs shall be so designed and constructed that when assembled and wired as in normal use, there is no risk that, as a result of undue pressure, live parts could penetrate the cover or become so disposed as to reduce creepage distances and clearances below those given in Clause 8.

9.3.1 Compliance shall be checked by the following test (an example of a suitable apparatus is shown in Figure 2).

The design of the apparatus shall be such that a steady force of 240_{-10}^0 N can be applied to those places where the possibility of a failure exists, the force being applied through a metal test pressure block as shown in Figure 2.

Each sample shall be subjected to the force at each chosen place in turn. During each application of force, a test voltage of $2\ 000\text{ V} \pm 60\text{ V}$ 50 Hz of substantially sinusoidal waveform is applied for 60_{0}^{+5} s between all live parts bonded together and the earthed test pressure block.

During the test no flashover or breakdown shall occur.

After the test it shall not be possible to touch live parts with test 11 of BS EN 61032:1998 applied with a force of 30_{-2}^0 N.

9.4 Where a plug is supplied fitted with a flexible cord, the free end of such an assembly shall be encapsulated in insulating material.

NOTE This does not apply to assemblies supplied to equipment manufacturers for incorporation into their equipment.

9.4.1 Compliance shall be checked by inspection.

10 Provision for earthing

10.1 All accessible metal parts of plugs shall be in effective electrical contact with the earthing plug pin, except that metal parts on, or screws in or through, non-conducting material, and separated by such material from current-carrying parts in such a way that in normal use they cannot become live, need not be in effective electrical contact with the earthing pin.

The earth pin shall be provided with a terminal or termination such as to provide a joint of low resistance with the earth conductor of a flexible cord.

NOTE Metal parts having an accessible surface coating of lacquer or enamel are accessible metal parts within the meaning of this requirement.

10.1.1 Compliance shall be checked by inspection and the following:

- a) for metal parts insulated from live parts, by the test described in **15.1.3**;
- b) for metal parts connected to an earthing terminal or earthing plug pin, by the following test.
A current of $25 \text{ A} \pm 0.75 \text{ A}$, derived from an a.c. source having a no-load voltage not exceeding 12 V, is passed for 60^{+5}_0 s between the remote end of the protective conductor of a 3-core flexible cord (cut to a length of $150 \text{ mm} \pm 5 \text{ mm}$ measured from the nearest edge of the earthing pin) and the remote end of the earthing plug pin and any accessible metal part intended to be earthed, taking account of the following:
 - 1) for non-rewirable plugs, the manufacturer's connection is tested as supplied, with the flexible cord cut to a length of $150 \text{ mm} \pm 5 \text{ mm}$ measured from the nearest edge of the earthing pin, precoiled flexible cords being extended before measurement.
 - 2) for rewirable plugs, 1.25 mm^2 flexible cord complying with Table 27 of BS 6500:2000 shall be used:
 - i) for screw type terminals the clamping screw shall be tightened with a torque equal to two-thirds of the appropriate value given in Table 3a;
 - ii) for clamp-type (screwless) terminals the connection shall be made in accordance with the manufacturer's instructions.

The resistance between the earthing terminal or termination and any other nominated metal part shall not exceed 0.05Ω .

Table 3a — Torque values for screws and nuts

Declared diameter of screw thread mm	Torque		
	For metal screws (see Note 1) N·m	For other metal screws and nuts N·m	For screws of insulating material N·m
Up to and including 2.8	0.2	0.4	0.4
Over 2.8, up to and including 3	0.25	0.5	0.5
Over 3, up to and including 3.2	0.3	0.6	0.6
Over 3.2, up to and including 3.6	0.4	0.8	0.6
Over 3.6, up to and including 4.1	0.7	1.2	0.6
Over 4.1, up to and including 4.7	0.8	1.8	0.9
Over 4.7, up to and including 5.3	0.8	2.0	1.0
Over 5.3, up to and including 6	—	2.5	1.25

NOTE 1 This column applies to metal screws without heads if the screw when tightened does not protrude from the hole, and to other metal screws which cannot be tightened by means of a screwdriver with a blade wider than the diameter of the screw.

NOTE 2 The recording of a measured value given in this table is considered to comply with this part of BS 1363 on condition that the uncertainty of measurement at not less than 95 % confidence level does not exceed $\pm 10 \%$.

11 Terminals and terminations

11.1 Terminals and terminations shall provide for effective clamping and securing of conductors connected to them, so that efficient electrical connection is made.

11.1.1 Compliance shall be checked in accordance with **11.2** to **11.9**.

11.2 Rewirable plugs shall be provided with terminals as defined in **3.8** or **3.9**.

11.2.1 Compliance shall be checked by inspection.

11.3 Non-rewirable plugs shall be provided with soldered, welded, crimped or similar terminations; for all these methods of termination, not more than one strand of a 0.5 mm² conductor or two strands of other sized conductors shall be fractured during connection.

Screwed and “snap-on” terminals shall not be used. Crimped connections shall not be made on to pre-soldered flexible cords unless the soldered area is entirely outside the crimp.

A4 *Text deleted* **A4**

A terminal or termination shall not be provided on an ISOD.

11.3.1 Compliance shall be checked by inspection and measurement.

11.4 Terminals in rewirable plugs shall permit the connection, without special preparation, of flexible cords having nominal conductor cross-sectional areas of 0.5 mm² to 1.5 mm².

11.4.1 Compliance shall be checked by inspection and fitting the appropriate conductors.

11.5 Where pillar terminals are used they shall have clamping screws of sufficient length to extend to the far side of the conductor hole. The end of the screw shall be slightly rounded so as to minimize damage to the conductors. The sizes of the conductor hole and the clamping screw shall be such that the clearance between each side of the major diameter of the clamping screw and the conductor hole does not exceed 0.4 mm.

11.5.1 Compliance shall be checked by inspection and measurement.

11.6 Terminal screws shall have a declared outside diameter of not less than 3 mm or be not smaller than 6 B.A.

Thread cutting and/or thread forming screws shall not be used.

11.6.1 Compliance shall be checked by inspection and measurement.

11.7 Insulating barriers in rewirable plugs shall be an integral part, so arranged that with the cord anchorage rendered inoperative and the earth or line conductors becoming detached from their respective terminals, there is negligible risk of the following:

- a) the earth conductor coming into contact with parts at line potential;
- b) the line conductor coming into contact with the line pin assembly.

11.7.1 Compliance shall be checked by inspection and by the following test.

The plug is wired as in normal use with a 0.5 mm² 3-core flexible cord as given in Table 27 of BS 6500:2000 in accordance with the manufacturer’s instructions. All terminal screws or nuts are tightened to the appropriate torque given in Table 3a.

A continuity indicating circuit operating at not less than 40 V is connected between the conductors and the other parts nominated. All terminal screws are then loosened and the cord anchorage rendered inoperative and the cover of the plug refitted. For plugs fitted with clamp type (screwless) terminals the conductor clamp shall be rendered inoperative. The flexible cord is then withdrawn from the plug at a rate not exceeding 50 mm/min, the direction of the pull being varied, until the earth core is pulled free of the plug. The test is made six times in all. For each new test a fresh section of the cord is fitted and the flexible cord rotated through approximately 60° in the plane perpendicular to its major axis in a clockwise direction before fitting unless the design is such that this is not practicable.

There shall be no contact between parts at line potential and the earth conductor or between the line conductor and line pin assembly, thus bypassing the fuse link.

11.8 Rewirable plugs shall be designed so that they can be wired in a manner which prevents strain to the earth connection before the line and/or neutral connection when the cord anchorage is rendered inoperative.

11.8.1 Compliance shall be checked by inspection and manipulation using a plug wired in accordance with the manufacturer's instructions.

11.9 In rewirable plugs terminals shall be so located or shielded that should a strand of a flexible conductor escape when the conductors are fitted, there is negligible risk of accidental connection between live parts and accessible external surfaces, or of a stray strand bypassing the fuse link.

11.9.1 Compliance shall be checked by inspection, and by the following test. Compliance shall be checked by inspection, and by the following test.

A length of insulation in accordance with the manufacturer's instructions is removed from the end of a flexible conductor having a nominal cross-sectional area of 1.5 mm^2 . One strand of the flexible conductor is left free and the other strands are fully inserted into and clamped in the terminal. The free strand is bent, without tearing the insulation back, in every possible direction, but without making sharp bends round barriers unless a bend is reproduced by the replacement of the cover.

The free strand of a conductor connected to a live terminal, shall not:

- a) touch any metal part so as to by-pass the fuse link;
- b) touch any metal part which is accessible or is connected to an accessible metal part;
- c) reduce creepage distance and clearance to accessible surfaces to less than 1.3 mm.

The free strand of a conductor connected to an earthing terminal shall not touch any live parts.

11.10 Clamp type (screwless) terminals shall be so designed that they make electrical contact to the specified conductors, between metal surfaces with sufficient pressure, and without additional means to maintain the clamping pressure. They shall not cause undue damage to the conductors.

NOTE Conductors are considered to be unduly damaged if they show deep or sharp indentations.

It shall be clear how the connection and disconnection of the conductors is intended to be effected.

The intended disconnection of a conductor shall require an operation to unlatch the clamp manually prior to removing the conductor.

11.10.1 Compliance shall be checked by the following.

- a) Inspection of three sample plugs.
- b) The following test is carried out on each terminal of the three sets of L, N and E terminals supplied in the test sample. For the purposes of this test, terminals are removed from the test sample or alternatively supplied separately.

Tests are carried out on each line, neutral and earth terminal separately with individual flexible conductors, first with conductors having the largest cross-sectional area, and then with conductors having the smallest cross-sectional area, as specified in **11.4**.

Conductors are connected and disconnected five times, on each terminal, new conductors being used each time, except for the fifth time, when the conductors used for the fourth connection are reconnected at the same place.

For each insertion, the conductors are inserted so that adequate connection is obvious. After insertion, the conductor is subjected to a pull of $30 \text{ }_{-2}^0 \text{ N}$. The pull is applied without jerks for $60 \text{ }_0^{+5} \text{ s}$, in a direction equivalent to that in which the conductor lies when the terminal is mounted in the plug.

During the application of the pull, the conductor shall not come out of the terminal. After these tests neither the terminals nor the clamping means shall have deteriorated in a manner impairing their further use and not more than one strand of a 0.5 mm^2 conductor or two strands of other sized conductors shall be fractured.

11.11 Clamp type (screwless) terminals shall be so constructed that incorrect fitting of the conductor is prevented.

11.11.1 Compliance shall be checked by inspection.

11.12 Clamp type (screwless) terminals shall be adequately located in the plug when assembled for normal use.

11.12.1 Compliance shall be checked by inspection, and by the mechanical strength test given in **20.1.3**.

12 Construction of plugs

12.1 The disposition of the plug pins (including ISODs where applicable) shall be as shown in Figure 4a).

12.1.1 Compliance shall be checked by inspection.

12.2 The outline of the plug shall not exceed the dimensions shown in Figure 4a) for a distance of not less than 6.35 mm from the engagement surface and within these dimensions there shall be no axial projection from the engagement surface of the plug, except that at a distance more than 6.35 mm from the engagement surface the outline of the plug may exceed the dimensions shown in Figure 4a) in the plane of the earth pin and in the plane of the cord entry to facilitate the removal of the plug from the socket. Pin disposition, length and body outline shall be checked by use of the gauge shown in Figure 5 in accordance with the following test. Pin and sleeve dimensions shall be checked by measurement and shall comply with Figure 4a), except for non-solid pins and ISOD where the chamfers shall generally fall within the profiles of Figure 4a) and their adequacy shall be checked by the tests of **12.9.5**. ISODs shall be of generally rectangular cross-section. 'T' sections are not permitted although castellated cross-sections are permitted provided their dimensions comply with Figure 4b) and all the other requirements of the standard are met.

The maintenance of these dimensions shall not rely on the terminal screws.

Plugs fitted with an ISOD shall comply with all the dimensions specified in Figure 4a) with the exception of the ISOD width which shall be 4.05 mm max and 3.90 mm min and its height which shall be 8.05 mm max and 7.75 mm min.

12.2.1 Compliance shall be checked by inspection, measurement and by the use of the gauge shown in Figure 5.

For the gauging test rewirable plugs shall be fitted with a 3-core 1.25 mm² flexible cord as given in Table 27 of BS 6500:2000. Non-rewirable plugs shall be tested as delivered.

With the gauge in an approximately vertical position and the engagement surfaces of the plug and the gauge parallel to each other, the line and neutral pins shall be entered into the gauge for a distance not exceeding 2 mm. The plug shall then enter the gauge fully when a force of 10 N or less is applied to the centre of the plug at right angles to the engagement surface and without any additional force being applied to the pins to bring them into alignment.

In the case of plugs with ISODs, due to the flexibility of plastic materials some additional alignment of the ISOD is allowed when inserting into the Figure 5 gauge. Where alignment cannot be maintained the test given in BS 1363-2:1995, **13.8**, shall be applied and the maximum withdrawal force from a socket-outlet conforming to BS 1363-2 shall not exceed 36 N.

12.3 No part of a line or neutral pin shall be less than 9.5 mm from the periphery of the plug measured along the engagement surface.

12.3.1 Compliance shall be checked by measurement.

12.4 A fuse link complying with BS 1362:1973 shall be provided within the body of the plug and the fuse link shall be mounted in appropriate contacts only between the line terminal or termination and the corresponding plug pin in such a way that it cannot be displaced when the plug is in use. The design shall be such that the fuse link cannot be left in inadequate contact when the plug cover, fuse-cover or the fuse-carrier is replaced and firmly secured in position.

A manufacturer of plugs may supply plugs in part assembled form, with or without an appropriate fuse, direct to a manufacturer for incorporation in other equipment, provided that when assembled the complete plug complies with this part of BS 1363.

It shall be impossible to replace the fuse link in a plug unless the plug is completely withdrawn from the socket-outlet.

For non-rewirable plugs the current rating of the fuse link shall not exceed the value given in Table 2 for the appropriate size of the flexible cord.

12.4.1 Compliance shall be checked by inspection.

12.5 In non-rewirable plugs, where the fuse link is retained by means of a fuse carrier, this device shall be either:

- a) non-detachable during normal replacement of the fuse link; or
- b) readily identifiable in relation to its plug by means of marking.

12.5.1 Compliance shall be checked by inspection.

12.6 The base and cover of non-rewirable plugs shall be permanently attached to each other, such that the flexible cord cannot be separated without making the plug permanently useless, and the plug cannot be opened by hand or by using a general purpose tool, for example a screwdriver used as such. A plug shall be considered to be permanently useless when, for reassembling, the plug parts or materials other than the original have to be used.

The base and cover of rewirable plugs shall be firmly secured to each other. It shall not be possible to remove the cover unless the plug is completely withdrawn from the socket-outlet. Any fixing screws shall be captive.

12.6.1 Compliance shall be checked by inspection and by the following tests as applicable.

- a) Each plug cover fixing screw has a pull of 60_{-2}^0 N exerted upon it for 60_{0}^{+5} s whilst the surface temperature of the product is $70^{\circ}\text{C} \pm 5^{\circ}\text{C}$. The test is carried out using apparatus similar to that shown in Figure 6 and for the test the plug cover and apparatus are placed in an oven until they reach the required temperature.

At the end of the test any screw thread shall be serviceable and any insert shall not have moved to such an extent that correct assembly of the plug is prevented.

- b) For rewirable plugs having covers fixed by means other than screws and for non-moulded-on, non-rewirable plugs, all the plug pins are clamped together in a suitable jig and subjected to a pull of 60_{-2}^0 N whilst suspending the cover by means of a "nest" to suit the plug cover profile. The test is carried out in an oven at a temperature of $70^{\circ}\text{C} \pm 5^{\circ}\text{C}$ and the pull applied for 60_{0}^{+5} s after the temperature has been attained.

After the test it shall not be possible to touch live parts with the test pin shown in Figure 1 applied with a force of 5_{-1}^0 N.

- c) Non moulded on, non-rewirable plugs are tested with the flexible cord supplied. The plug pins are clamped in the vertical position using a suitable jig with the plug pins uppermost. The plug lead fitted shall A_3 be suitably fitted with a cord totalling 1 m in length in such a way that any joint has negligible effect A_3 and a weight of $(3^{+0.06})$ kg fixed to the end. With the weight initially held (0.5 ± 0.05) m from the end of the cord anchorage, and at the same height. The weight is allowed to fall A_3 freely A_3 and this test shall be carried out 5 times.

After this test the plug cover shall be in place and show no damage. A_4 If the cord becomes detached during this test but the plug cover remains in place and shows no damage the plug shall be deemed to have passed this test. A_4

Compliance shall be checked by inspection.

12.7 Plugs shall be so designed and constructed that they cannot readily be deformed to allow access to live parts.

12.7.1 Compliance shall be checked by inspection and by the following test.

Immediately after the test described in Clause 16, test probe 11 of BS EN 61032:1998 is applied to the accessible surface of the plug with a force of 30_{-5}^0 N. It shall not be possible to touch live parts.

12.8 For non-rewirable plugs means shall be provided to prevent loose strands of a conductor or current-carrying parts from reducing the minimum insulation thickness requirements between such parts and all accessible external surfaces of the plug.

12.8.1 Compliance shall be checked by inspection and the test described in **15.2**.

12.9 Materials other than brass A_4 or nickel plated brass A_4 shall not be used in the construction of Line and Neutral plug pins except for sleeves of pins as specified in **12.16**. Plug pins and ISODs shall comply with **12.9.1**. Non-solid pins A_3 *Text deleted* A_3 shall comply with **12.9.2**.

12.9.1 All exposed surfaces of plug pins shall be smooth and free from burrs or sharp edges and other irregularities which could cause damage or excessive wear to corresponding socket contacts or shutters.

12.9.1.1 Compliance shall be checked by inspection.

12.9.2 Those surfaces of the non-solid plug pins which are visible when the plug is correctly assembled shall be free of apertures.

12.9.2.1 Compliance shall be checked by inspection.

12.9.3 All seams and joints of non-solid plug pins shall be closed over their entire length.

12.9.3.1 Compliance shall be checked by inspection and in case of doubt by the following test.

Push a probe of 0.2 mm diameter of steel complying with Table 1 of BS 5216:1991 into all seams and joints. Check that the test probe does not enter into any seam or joint to a depth greater than the thickness of the material from which the plug pin is formed.

12.9.4 Plug pins and ISODs shall have adequate strength to withstand the stresses of normal use.

12.9.4.1 For solid pins A_3 *Text deleted* A_3 , compliance shall be checked by the following test.

Position a pin on the fixed anvil of the apparatus, as shown in Figure 32, with its contact surfaces in the horizontal plane. Apply a force of $1\ 100_{-10}^0$ N to the movable anvil by any convenient method such that the pin is strained at a rate not exceeding 10 mm/min.

The test shall be made separately on the line, neutral and earth pins applying the load perpendicular to the major axis surfaces of the pins.

After this test the plug shall fit the gauge to Figure 5 when used in the manner described in **12.2.1**.

12.9.4.2 For non-solid pins, compliance shall be checked by the following tests.

- a) Position a pin on the fixed anvil of the apparatus, as shown in Figure 32, with its contact surfaces in the horizontal plane. Bring the movable anvil to rest against the upper surface of the pin. Apply a force of 800_{-10}^0 N to the movable anvil 50 times without impact.

The test shall be made separately on the line, neutral and earth pins applying the load perpendicular to the major axis surfaces of the pins. If there is a joint or seam in one of the major axis surfaces of a pin then the test shall be made twice. The seam or joint shall face the moving anvil for the first test and shall face the fixed anvil for the second test.

After the test the pins shall comply with **12.9.2** and **12.9.3** and the plug shall fit gauge shown in Figure 5 when used in the manner described in **12.2.1**.

- b) Separate specimens shall be used to check in accordance with the following test.

Position a pin on the fixed anvil of the apparatus, as shown in Figure 32, with the widest surface in the horizontal plane. Bring the movable anvil to rest against the upper surface of the pin. This quiescent position shall be taken as the datum point. Apply a force to the movable anvil by any convenient method such that the pin is strained at a rate not exceeding 10 mm/min. Measure the applied force when the movement of the anvil from the datum point reaches $1.5_{-0.1}^0$ mm. The test shall be made separately on the line, neutral and earth pins applying the load perpendicular to the major axis surfaces of the pins. If there is a joint or seam in one of the major axis surfaces of a pin then the test shall be made twice. The seam or joint shall face the moving anvil for the first test and shall face the fixed anvil for the second test. The force shall be not less than 1 100 N.

12.9.4.3 For ISODs, compliance shall be checked by the following test.

Position the ISOD on the fixed anvil of the apparatus as shown in Figure 32 with the widest surface in the horizontal plane. Bring the moveable anvil to rest against the upper surface of the ISOD. The quiescent position shall be taken as the datum point. Apply a force to the moveable anvil by any convenient method such that the ISOD is strained at a rate of 10 ± 2 mm/min.

A force of $400 + 10/0$ N is applied and the measured deflection shall not exceed 1.5 mm. The ISOD shall not be broken or show cracks that are visible with normal or corrected vision without additional magnification.

After the test the plug shall fit the Figure 5 gauge when used in the manner described in 12.2.1 with a force not exceeding 20 N.

When testing a plug fitted with an ISOD due to the flexibility of plastic materials some additional alignment of the ISOD is allowed when inserting into the Figure 5 gauge. Where alignment cannot be maintained the test of Clause 13.8 of BS 1363-2 shall be applied and the maximum withdrawal force from a socket-outlet complying with BS 1363-2 shall not exceed 36 N.

12.9.5 Plugs with A_4 nickel plated brass pins, A_4 non-solid pins and/or ISODs shall not cause excessive wear to socket contacts or shutters of socket-outlets in accordance with BS 1363-2. For plugs with A_4 nickel plated brass pins and/or A_4 non-solid pins compliance shall be checked by 12.9.5.1. For plugs with ISODs compliance shall be checked by 12.9.5.2.

12.9.5.1 Compliance shall be checked by the following tests.

The test is carried out A_3 with plugs with A_4 nickel plated brass pins and/or A_4 non-solid pins and three different types of new A_3 socket-outlets in accordance with BS 1363-2:1995+A4. A_3 Two types of the socket-outlet shall have the shutters operated by the earth pin, one of which is preferably operated by all three pins and one of which is preferably operated by line and neutral pins only A_3 .

The combination of rewirable plugs having A_4 nickel plated brass pins and/or A_4 non-solid pins and each type of socket-outlet as described shall make and break a current of $13 \text{ A} \pm 0.4 \text{ A}$, non-rewirable plugs shall be tested with the rated current appropriate to the flexible cord given in Table 2, at $250 \text{ V} \pm 10 \text{ V a.c.}$ 15 000 times (30 000 movements) in a substantially non-inductive circuit.

Each plug is inserted into and withdrawn from the socket-outlet at a rate of six insertions and six withdrawals per minute, the speed of travel of the plug being approximately 150 mm/s. The periods during which the plug is inserted and withdrawn shall be approximately equal. The plug pins are renewed or a new plug is used after each 5 000 insertions and withdrawals. For the purpose of this test no lubrication shall be applied to the pins of the plug or the socket-outlet contacts.

After the test the shutters of the socket-outlets shall be operating satisfactorily, the socket contacts safely shielded and the socket-outlets shall be in accordance with 9.1, 16, 15, 13.4.1a), 10.2, 13.6, 13.7 and 13.8 of BS 1363-2:1995 and the permitted values of voltage drop specified in C_1 13.4.1a) C_1 of BS 1363-2:1995 for the plug pin to socket contact measurements increased by 50 %. The pins of the plug shall remain intact with no openings in the surface, joints or seams which will accept the probe specified in 12.9.3.

A_4 There shall be no visible evidence of peeling or flaking of plating. A_4

12.9.5.2 Compliance shall be checked by the following.

Using a selection of three different makes of rewirable plugs conforming to this standard and three different makes of unswitched socket-outlets conforming to BS 1363-2, selected to represent different earth contact designs, the earth resistance between the earthing plug pin and the earthing socket contact of the socket-outlets shall be established in accordance with BS 1363-2, 10.2.1b).

All socket-outlets shall be of the type where the earth pin or ISOD of a plug inserted into the socket-outlet operates the shutter mechanism.

A_3 Text deleted A_3

The test shall be made using a separate sample of plug with ISOD for each type of socket-outlet, with each sample being inserted into and withdrawn from the socket-outlet at a rate of six insertions and six withdrawals per minute, the speed of travel of the plug being approximately 150 mm/s. The period during which the plug is inserted and withdrawn shall be approximately equal. For the purpose of this test no lubrication is applied to the plugs or sockets either prior to or during the test.

After 5 000 insertions and withdrawals the standard rewirable plug used prior to the test, for each type of socket-outlet shall be reinserted and the earth resistance test repeated. After the test the earth resistance between the earthing plug pin and the earthing socket contact of the socket-outlets shall be in accordance with BS 1363-2:1995, 10.2.1b).

The socket-outlet shall be examined and shall show no sign of damage that would impair further use. The plugs under test shall show no damage and shall comply with the dimensional requirements of this standard.

After the test, the shutters of the socket-outlet shall be operating satisfactorily and the socket contacts shall be safely shielded.

12.9.6 Plug pins and ISODs shall have adequate mechanical strength to ensure that they cannot be distorted by twisting.

12.9.6.1 Compliance shall be checked by inspection and by the following test.

The plug is clamped in a block as shown in Figure 33. Each pin is twisted about its longitudinal axis by applying a torque of $1 \text{ N}\cdot\text{m} \pm 10 \%$, for 60^{+5}_0 s . The torque tube and its position on the plug pin shall be as shown in Figure 33. After each pin has been separately twisted the plug shall fit the gauge shown in Figure 5. The test shall then be repeated with each plug pin being twisted in the opposite direction to that of the first test. After this second test the plug shall fit the gauge shown in Figure 5. In each case the gauge is used in the manner as described in **12.2.1**.

12.10 The terminals of earthing and neutral plug pins shall be formed as one piece with or shall be permanently connected to the pin in such a way that efficient electrical connection is made that cannot work loose in use. This connection shall not be made by means of a screw.

The contact for the fuse link connected to the line terminal or termination shall be formed in one piece with the fixed part of the terminal or termination, or be permanently connected to it in such a way that it cannot work loose in normal use, and the other contact for the fuse link shall be similarly connected to the corresponding plug pin. These connections shall not be made by means of screws.

The line terminal or termination shall provide for effectively clamping and securing conductors connected to it so that efficient electrical connection is made with the fuse link.

12.10.1 Compliance shall be checked by inspection and the tests described in **20.1.3** and Clause **16**.

12.11 Plugs shall be so designed that when fully assembled the pins are adequately retained in position such that there is no likelihood of them becoming detached from the plug during normal use.

12.11.1 Compliance shall be checked by the following test.

After the tests described in Clause **20** each pin is subjected for 60^{+5}_0 s to a pull of 100^{+0}_{-2} N without jerks in the direction of the major axis. The plug is mounted using the steel plate shown in Figure 7. The apparatus is placed within an oven and the pull is applied at least 1 h after the plug body has attained the test temperature of $70 \text{ }^\circ\text{C} \pm 5 \text{ }^\circ\text{C}$ while maintained at this temperature.

After the test the plug pin shall comply with the gauge shown in Figure 5 when used in the manner as described in **12.2.1**.

12.12 The degree of flexibility of mounting of the plug pins or the angular movement of the pins in the base shall be not greater than $3^\circ 30'$ in the directions shown in Figure 8 from an axis which is perpendicular to the plug engagement A_3 surface A_3 when the pins are subjected to a force as shown in Figure 8.

12.12.1 Compliance shall be checked by inspection and in case of doubt by the following test.

NOTE Plugs may be checked using an apparatus similar to that shown in Figure 8. (Other methods of measuring the $3^\circ 30'$ deflection may be used.)

The plug is clamped in the mounting block by means of any two of the plug pins in such a manner as to ensure that the A_3 engagement surface A_3 of the plug, from which the plug pins project, is supported and in contact with the corresponding flat surface of the mounting block. The back of the plug is not supported and does not come into contact with the fixture. The axis of the clamped pins is horizontal.

The unclamped pin shall be tested for declination from the horizontal by applying a force of $4.4^{+0}_{-0.2} \text{ N}$, $25^{+0}_{-0.5} \text{ mm}$ from the engagement A_3 surface A_3 of the plug and parallel with it in the four directions shown in Figure 8. The test shall be repeated in turn on the other two pins of the plug.

During each test the declination from the horizontal measured on the scale shall not exceed $3^\circ 30'$. After all tests have been completed the plugs shall fit the gauge shown in Figure 5 when used in the manner as described in **12.2.1**.

12.13 Suitable means shall be provided for withdrawing the plug without subjecting the flexible cord to stress.

12.13.1 Compliance shall be checked by inspection.

12.14 Non-rewirable plugs shall be fitted with flexible cords in accordance with **19.4**.

12.14.1 Compliance shall be checked by inspection.

12.15 Conductive component parts of plugs shall be so located and separated that, in normal use, they cannot be displaced so as to affect adversely the safety or proper operation of the plug.

12.15.1 Compliance shall be checked by inspection and manual manipulations.

12.16 Line and neutral plug pins shall be fitted with insulating sleeves. The dimensions of the pin and sleeve shall fall within those given in Figure 4a). Sleeves shall not be fitted to any earthing plug pin.

12.16.1 Compliance shall be checked by inspection and by measurement for pin and sleeve and use of the gauge shown in Figure 5 as described in **12.2.1** for socket-outlet compatibility.

12.17 Plug pin sleeves shall have adequate electric strength, resistance to abrasion and resistance to deformation due to overheating of pins.

12.17.1 Compliance shall be checked by the tests given in **12.17.2** to **12.17.4**.

12.17.2 A 50 Hz voltage of substantially sinusoidal waveform is applied between each L and N pin and a thin metal strip of between 5.5 mm and 6 mm width wrapped around the base of the plug pin sleeve adjacent to the base of the plug. Initially not more than 500 V is applied, the voltage then being raised to $1\,250\text{ V} \pm 30\text{ V}$ which is maintained for 60^{+5}_0 s .

During the test no breakdown or flashover shall occur.

12.17.3 The test apparatus for resistance to abrasion (see Figure 9) comprises a horizontally disposed beam pivoted about its centre point. A short length of steel wire, $1\text{ mm} \pm 0.02\text{ mm}$ in diameter and bent into a U-shape, the base of the U being straight, with no surface defects, is rigidly attached at both ends to one end of the beam so that the straight part of the wire projects below the beam and is parallel to the axis of the beam pivot.

The plug is held in a suitable clamp as shown in Figure 9 in such a position that the straight part of the steel wire rests upon the plug pin at right angles to it and the plug pin slopes downward at an angle between 5° and 10° to the horizontal. The beam is loaded so that the wire exerts a force of $4^{+0}_{-0.1}\text{ N}$ on the pin.

The plug is moved backwards and forwards in a horizontal direction in the plane of the axis of the beam so that the wire rubs along the pin. The length of pin thus abraded is approximately 9 mm of which approximately 7 mm is over the insulating sleeve.

The plug is moved 10 000 times in each direction (20 000 movements) at a rate of 25 movements to 30 movements per minute.

The test shall be made on one pin of each plug.

After the test the sleeve shall show no damage which might impair the further use of the plug. The sleeve shall not have been penetrated or creased and shall satisfy the tests described in **12.17.2**, any abraded brass contamination on the sleeve having been removed.

12.17.4 A set of three specimen pins is tested by means of the apparatus shown in Figure 10 which has a blade $0.70^{+0.05}_0\text{ mm}$ wide and a radius of $3\text{ mm} \pm 0.1\text{ mm}$. The test is made on one pin of each plug not used for the test described in **12.17.3**.

A specimen is positioned as shown in Figure 10 and the apparatus is loaded so that the blade exerts a force of $2.5^{+0}_{-0.1}\text{ N}$ on the specimen. The apparatus, complete with specimen, is then placed in a heating cabinet at $200^{+0}_{-8}\text{ }^\circ\text{C}$ for a period of 120^{+0}_{-5} min , after which the specimen is removed and immediately cooled by immersion in water at approximately room temperature.

The thickness of the insulation remaining at the point of impression is measured and shall not have been reduced by more than 50 %.

A4 12.18 Switches shall be so constructed that undue arcing cannot occur when the switch is operated slowly.

The switch in any switched fused plug shall disconnect at least the supply to the line terminal.

Double pole switches shall make or break each pole with one movement of the actuator.

12.18.1 Compliance shall be checked by inspection and by the following test.

Following the test described in Clause 17, the circuit is broken a further 10 times, each time moving the actuating member by hand over a period of approximately 2 s in a manner such as to attempt to stop the moving contact in an intermediate position causing arcing. The actuating member shall be released after approximately 2 s and any arcing shall cease.

12.18.2 The actuating member of a switch shall not remain at rest in the off position whilst the switch contacts remain closed. The actuating mechanism shall be so constructed that when operated the switch can remain only in a position giving adequate contact or adequate separation of contacts. For switched fused plugs that cannot be dismantled after assembly an additional new set of three samples prepared with the contacts closed is supplied by the manufacturer for this test.

12.18.2.1 Compliance shall be checked by inspection and the test of **12.18.3**.

12.18.3 The necessary force F to switch off shall first be measured and the force should be applied to the extremity of the actuating member.

With the actuating member of the switch in the closed position, the fixed and moving contacts of each pole shall be mechanically fixed together to provide the most onerous condition. When fixing the contacts, care should be taken to ensure that the test result is not unduly affected.

The actuating member shall be subjected to a test force as defined in Table 3b. This force shall be applied in one smooth and continuous motion to the extreme point of the actuating member in the most favourable direction to open the contacts for a period of 10 s.

If locking means are designed to lock the actuating member in the opened position, it shall not be possible to lock the actuating member in this position while the force is applied.

After the test and when the test force is no longer applied, the actuating member shall not remain at rest in the "OFF" position. **A4**

A4

Table 3b — Actuator test force

Type of actuator	Test force	Minimum test force N	Maximum test force N
Switch actuator	$3F$	50	150
F is the normal operating force in new condition. The test force shall be $3F$ with the stated minimum and maximum values applied.			
NOTE 1 The use of grease and the like is not considered to be a mechanical means.			
NOTE 2 The specimen may be dismantled where necessary in preparation for this test but adequate care must be taken that the test specimen or components are not damaged during this preparation.			

A4

13 (Not used)

14 Resistance to ageing and to humidity

14.1 Resistance to ageing

Plugs shall be resistant to ageing.

14.1.1 Compliance is checked by the following test.

Plugs are subjected to a test in a heating cabinet with an atmosphere having the composition and pressure of the ambient air and ventilated by natural circulation.

The temperature of the cabinet is kept at $70\text{ }^{\circ}\text{C} \pm 5\text{ }^{\circ}\text{C}$.

The specimens are kept in the cabinet for 168 h (0, +2) h.

NOTE 1 The use of an electrically heated cabinet is recommended.

NOTE 2 Natural circulation may be provided by holes in the walls of the cabinet.

After the treatment, the samples are removed from the cabinet and kept at room temperature and relative humidity for 1 h; and following which they are examined and shall show no damage which:

- would lead to non-compliance with this standard;
- would impair safety;
- would prevent further use.

14.2 Resistance to humidity

Plugs shall be proof against humid conditions which may occur in normal use.

14.2.1 Compliance shall be checked by the humidity treatment described below followed within 20 min by the measurement of the insulation resistance and by the electric strength test specified in Clause 15.

Rewirable plugs are fitted with $1\ 000\text{ mm} \pm 50\text{ mm}$ of 3-core 1.25 mm^2 PVC cord as given in Table 27 of BS 6500:2000. Non-rewirable plugs are tested with $1\ 000\text{ mm} \pm 50\text{ mm}$ of the flexible cord with which they are supplied measured from the centre of the earth pin.

To suit the ambient conditions at the time of test, a convenient temperature, T (in $^{\circ}\text{C}$), between $20\text{ }^{\circ}\text{C}$ and $30\text{ }^{\circ}\text{C}$, is chosen as a reference temperature. The sample is brought to a temperature of between T and $T + 4\text{ }^{\circ}\text{C}$ and is then placed in a humidity cabinet containing air with a relative humidity maintained between 85 % and 95 %. The temperature of the air where the samples are placed shall be kept within $\pm 2\text{ }^{\circ}\text{C}$ of the chosen value T .

The sample is kept in the cabinet for $48\text{ }^{\text{h}}_{0}^{+1}$.

NOTE 1 In most cases samples may be brought to the chosen reference temperature by keeping them at this temperature for at least 4 h before the humidity treatment.

NOTE 2 A relative humidity of between 85 % and 95 % can be obtained by placing in the humidity cabinet a saturated solution of potassium nitrate (KNO_3) or sodium sulfate (Na_2SO_4) in water having a sufficiently large contact surface with the air.

In order to achieve the specified conditions within the cabinet it is necessary to ensure constant circulation of the air within the cabinet and, in general, to use a cabinet which is thermally insulated.

The tests described in Clause 15 shall be made in the humidity cabinet or immediately after removal of the specimen from the cabinet in a room where the specified temperature is maintained. Inspection shall not reveal any damage to the sample which would impair its use or safety within the requirements of this part of BS 1363.

15 Insulation resistance and electric strength

15.1 The insulation resistance and electric strength of plugs shall be adequate.

15.1.1 Compliance shall be checked by the tests described in **15.1.2** and **15.1.3**.

15.1.2 The insulation resistance is measured using a d.c. voltage of 500^{+250}_0 V the measurement being made for 60^{+5}_0 s, after application of the voltage. The insulation resistance is measured consecutively between:

- a) line and neutral terminals/terminations;
- b) line and neutral terminals/terminations connected together and:
 - 1) a metal foil in contact with the entire accessible external surface;
 - 2) the earthing terminal/termination;
 - 3) any metal part of a cord anchorage;

C1 c) each switched pole terminal of a switched plug and corresponding plug pin, with the switch contacts open. **C1**

The insulation resistance shall be not less than the following:

- i) 5 M Ω between parts of opposite polarity;
- ii) **A4** 5 M Ω between parts of opposite polarity connected together, and other parts, including earthed metal, intended to be insulated from them; **A4**

C1 iii) 2 M Ω across switch contacts with the switch open, where applicable. **C1**

One pole of neon indicators and the like shall be disconnected before making this test.

Where terminals/terminations are not directly accessible, e.g. in non-rewirable plugs, these tests shall be made using accessible parts, e.g. pins known to be connected to the terminations.

15.1.3 A 50 Hz voltage of substantially sinusoidal waveform is applied as described in **15.1.2**. Initially, not more than 1 000 V is applied, the voltage then being raised to 2 000 V \pm 60 V. The high voltage source used shall be such that when the output is adjusted to 2 000 V \pm 60 V for 60^{+5}_0 s and is then short circuited, the output current is not less than 200 mA. Any overcurrent protection shall not operate at a current less than 100 mA.

During the test no flashover or breakdown shall occur.

Glow discharges without drop in voltage shall be ignored.

One pole of neon indicators and the like shall be disconnected before making this test.

15.2 Non-rewirable plugs shall withstand a high voltage test, for which the test voltage shall be alternating, (50 Hz to 60 Hz) applied between all current-carrying parts connected together and a conducting electrode in contact with the entire outer accessible surface, omitting the engagement face. This test shall be carried out at 6 000 V \pm 100 V for a period between 3 s and 5 s.

During the test no breakdown or flashover shall occur.

Glow discharges without drop in voltage shall be ignored.

16 Temperature rise

16.1 Plugs and their surroundings shall not attain excessive temperatures in normal use.

16.1.1 Compliance shall be checked by the following tests.

The tests shall be carried out at rated voltage +10 %, –20 %.

For these tests, where conductors are connected to terminals, the terminal screws shall be tightened with a torque equal to two-thirds of the values given in Table 3a.

For rewirable plugs with clamp type (screwless) terminals the connection of the conductors shall be made in accordance with the manufacturer's instructions.

During the tests temperature rises are measured where overheating might result in a hazard and the values measured shall not exceed the values given in Table 4. Additionally the temperature rises of the line and neutral plug pins are measured by means of thermocouples using the apparatus shown in Figure 17. Temperature rises are determined by means of fine wire thermocouples so chosen and positioned that they have minimum effect on the temperature of the part under test. The thermocouples are attached by means of a mixture of equal parts of resin adhesive and zinc oxide, by soldering, or by other equally effective means.

NOTE If soldering is used, it is essential that care is taken to ensure that the heat from the soldering process does not affect the performance of the plug and that no electrical connections are bridged by solder.

If, in order to fix thermocouples, a non-rewirable plug is dissected to give access to the appropriate positions, the removed parts shall be replaced and if necessary shall be cemented in place so that no additional air spaces are created.

16.1.2 Rewirable plugs are tested with $1\,000\text{ mm} \pm 50\text{ mm}$ of 1.25 mm^2 3-core PVC insulated flexible cord as given in Table 27 of BS 6500:2000, non-rewirable plugs are tested with $1\,000\text{ mm} \pm 50\text{ mm}$ (measured from the centre of the earth pin) of the flexible cord supplied at an appropriate test current as given in Table 2.

The plug is fitted with a calibrated link, constructed and calibrated in accordance with Annex A, and is mounted in a flat insulating plate as shown in Figure 17. The supply conductors are attached to the line and neutral pins of the plug by means of clamps which also serve to retain the plug in position. The clamp screws are tightened to a torque of between $0.8\text{ N}\cdot\text{m}$ and $1.2\text{ N}\cdot\text{m}$. The assembly is mounted by means of screws in a standard steel flush-mounted socket-outlet box as shown in Figure 1b of BS 4662:1970, having a nominal internal depth of 35 mm which is mounted in a test cabinet as shown in Figure 17a).

The incoming cable and outgoing flexible cord shall enter the test cabinet through holes in the top surface which shall then be sealed to prevent circulation of air. The length of cable and flexible cord within the Figure 17 enclosure shall be of a maximum length of 600 mm and 850 mm respectively. Care shall be taken to position the cable and flexible cord away from the reference temperature measuring point so not to influence the derivation of plug temperature rise values.

The incoming cable shall be a 2.5 mm^2 PVC insulated and sheathed cable, as given in Table 8 of BS 6004:2000 and shall enter the socket-outlet mounting box through the standard knockout provided. This shall be fitted with a suitable rubber grommet, the point of entry being sealed to prevent the circulation of air. The length of cable within the socket-outlet box shall be $150\text{ mm} \pm 5\text{ mm}$ and the outer sheath and the circuit protective conductor shall be removed to within 20 mm of the point of entry. The test cabinet [Figure 17a)] is placed in an environment having an ambient temperature of $20\text{ }^\circ\text{C} \pm 5\text{ }^\circ\text{C}$. The test current as specified in Table 2 shall be passed through the plug and through a load connected to the flexible cord for a minimum continuous period of 4 h or longer until stability is reached with a maximum duration of 8 h, stability being taken as less than 1 K rise within 1 h.

The temperature rise is calculated by deducting the reference point temperature from the measurement point temperature recorded [see Figure 17a) and Figure 17b)] respectively).

Table 4 — Permitted temperature rises

Measurement point	Temperature rise K
Line pin spacer (see Figure 17)	37
Neutral pin spacer (see Figure 17)	37
Terminals or terminations	52
Accessible external surface	52

NOTE The recording of a measured value up to and including the specified maximum permissible limit for temperature rise is considered to comply with the requirements of the standard on condition that the uncertainty of measurement at not less than 95 % confidence level does not exceed $\pm 2\text{ }^\circ\text{C}$.

A4 17 Breaking capacity of switches incorporated in fused plugs

17.1 The breaking capacity of switches incorporated in plugs shall be adequate.

17.1.1 Compliance shall be checked by the following test. The switch shall make and break a current of $1.25 \times \text{rated current} \pm 0.4 \text{ A}$ (i.e. $1.25 \times 13 \pm 0.4 \text{ A}$) in a substantially non-inductive a.c. circuit at $275 \text{ V} \pm 5 \text{ V}$, 10 times in succession at intervals of approximately 30 s.

After the test the plug shall be capable of passing the subsequent tests detailed in Table 1 for the appropriate test sample. **A4**

A4 18 Normal operation of switches

18.1 Switches incorporated in plugs shall withstand, without excessive wear or other harmful effects, the electrical and mechanical stresses occurring in normal use.

18.1.1 Compliance shall be checked by the following tests. The voltage drop across each switched pole, measured at points immediately adjacent to the switch, shall not exceed 60 mV at rated current. The switch shall then make and break a current of $13 \text{ A} \pm 0.4 \text{ A}$ at $250 \text{ V} \pm 10 \text{ V}$ 15 000 times (30 000 movements) in a substantially non-inductive a.c. circuit at a rate of approximately six complete cycles per minute at regular intervals. The periods during which the switch is on and off shall be approximately equal. The means for operating the switch shall be such as to move the actuating member at a speed of approximately 300 mm/s both in making and breaking the circuit and shall be so positioned that the normal action of the mechanism is not interfered with in any way.

At the end of the test, the switch shall be capable of making and breaking the rated current of $13 \text{ A} \pm 0.4 \text{ A}$ at $250 \text{ V} \pm 10 \text{ V}$ and the voltage drop across each switched pole, measured as above, shall not exceed 75 mV.

The switch shall also pass the tests given in Clause 15, the test voltage being reduced by 25%. **A4**

19 Connection of flexible cords and cord anchorage

19.1 The entry of the flexible cord shall be between the current-carrying pins at the side of the plug opposite the earth pin. (See Figure 18.)

Provision shall be made for the entry and effective clamping without bending of 2-core and 3-core flexible cords for rewirable plugs as given in **A3** *Text deleted* **A3** Table 11, Table 12, Table 13, **A4** *Text deleted* **A4** Table 26 and Table 27 of BS 6500:2000, having nominal conductor cross-sectional areas not exceeding 1.5 mm^2 .

For non-rewirable plugs provision shall be made for the entry and adequate retention of the flexible cord with which the plug is supplied, once assembled it shall not be possible in normal use to affect the integrity of the cord anchorage.

NOTE Flexible cords with a mean overall dimension less than those given in **A4** Table 26 **A4** of BS 6500:2000 (such as Decorative Light cords) are permitted, provided a suitable retention aid is fitted to the cord or cord anchorage so that it conforms to this standard.

The cord anchorage shall be such that the conductors are relieved from strain, including twisting, where they are connected to the terminals or terminations.

The cord anchorage shall contain the sheath. Cord anchorages shall either be of insulating material or if of metal shall be provided with an insulating lining fixed to the metal parts.

Methods such as tying the flexible cord into a knot or tying the ends with string or the like shall not be used.

19.1.1 Compliance shall be checked by inspection and by the following tests.

- a) Rewirable plugs are fitted with **A4** a 2-core 0.5 mm^2 flexible cord as given in Table 26 of BS 6500:2000. **A4**. The conductors are introduced into the terminals and the terminal screws tightened **A4** to one-third of the appropriate torque values listed in Table 3a. **A4** The cord anchorage is used in the normal way, the clamping screws, if any, being tightened to a torque of two-thirds of that given in Table 3a. The assembly is then left untouched for a minimum of 24 h.

After this preparation, it shall not be possible to push the flexible cord into the plug to such an extent as to impair safety or so that the cord anchorage is loosened.

The flexible cord is then subjected 25 times to the pull given in Table 2. The pulls are applied without jerks in the most unfavourable position momentarily. Immediately afterwards, the flexible cord is subjected for 60^{+5}_0 s to the appropriate torque shown in Table 2, at a minimum distance of 150 mm from the cord entry.

NOTE It is not intended that the dimension of 150 mm is maintained during the application of the test torque.

These tests are then repeated but with the plug fitted with a 3-core flexible cord having a nominal conductor cross-sectional area of 1.5 mm^2 as given in Table 27 of BS 6500:2000.

b) For non-rewirable plugs the test is carried out with the cord with which it is supplied, using the appropriate load and torque as given in Table 2. The conductors of the flexible cord are severed at the point of termination prior to the test.

During this test the insulation of the flexible cord shall not be damaged.

A voltage of $3\,750 \text{ V} \pm 75 \text{ V}$ is applied for 60^{+5}_0 s between the conductors. Breakdown or flashover is considered to indicate damage to the flexible cord.

c) After the tests given in a) and b) the flexible cord shall not have been displaced by more than 2 mm.

For the measurement of longitudinal displacement a mark is made on the cord whilst it is subjected to the load given in Table 2, at a point adjacent to the anchorage in the case of rewirable plugs, or as close as practicable to the cord anchorage in the case of non-rewirable plugs, before starting the tests. After the test, the displacement of the mark on the flexible cord in relation to the cord anchorage is measured whilst the cord is again subjected to the load given in Table 2.

19.2 Cord anchorages in rewirable plugs shall anchor the cord securely to the plug. The design shall ensure the following:

- a) the cord anchorage cannot be released from the outside without the use of a tool;
- b) it shall not be possible to touch cord anchorage screws, if any, with test probe B of BS EN 61032:1998 when the plug is energized;
- c) the cord is not clamped by a metal part bearing directly on the flexible cord;
- d) at least one part of the anchorage is securely fixed to the plug;
- e) clamping the cord does not require the use of a special purpose tool;
- f) tightening the cord anchorage screws if any to the torque prescribed in Table 3a does not distort the engagement face of the plug to such an extent that compliance with **12.2** is affected;
- g) the cover may be correctly fitted without damage when the plug is wired with the largest specified flexible cord and all screws are tightened to the torque specified in Table 3a.

19.2.1 Compliance shall be checked by inspection and test.

19.3 Screws which are used when clamping the flexible cord shall not serve to fix any other components unless either the plug is rendered manifestly incomplete if the component is omitted or is replaced in an incorrect position, or the component intended to be fixed cannot be removed without further use of a tool.

19.3.1 Compliance shall be checked by inspection.

19.4 Non-rewirable plugs shall be fitted with flexible cords complying with BS 6500:2000 or with flexible cords complying with the requirements of the specification appropriate to the equipment to which they may be fitted. Connections shall be as given in Table 6.

19.4.1 Compliance shall be checked by inspection and a continuity test.

19.5 Non-rewirable plugs shall be so designed that the flexible cord is not subjected to excessive bending where it enters the plug.

19.5.1 Compliance shall be checked by the following test using an apparatus similar to that shown in Figure 18. The plug is fixed to the oscillating member of the apparatus so that when this is vertical the axis of the flexible cord at the point of entry is vertical and passes through the axis of oscillation.

Samples with flat flexible cords are mounted so that the major axis of the section is parallel to the axis of oscillation.

The flexible cord is loaded with a weight as given in Table 2.

The distance between the point of entry to the plug and the axis of oscillation is adjusted so that the weight makes the minimum lateral movement as the oscillating member moves. A current appropriate to the flexible cord fitted, as given in Table 2, is passed through the line and neutral conductors, the voltage between them being $250 \text{ V} \pm 10 \text{ V a.c.}$ If an earthing conductor is incorporated in the flexible cord it shall be connected at one end to the neutral conductor.

The oscillating member is moved backwards and forwards through an angle of $45^\circ \pm 3^\circ$ on either side of the vertical, the number of flexings being 10 000 at a rate of 60_{-10}^0 flexings per minute.

After 5 000 flexings, plugs with cords of circular section are turned through $90^\circ \pm 5^\circ$ about the cord entry centreline.

NOTE A flexing is one movement through 90° , either backwards or forwards.

During the test there shall be no interruptions of the current passing through the conductors and no short-circuit between them.

After the test the sample shall show no damage except that breakage of no more than 10 % of the total number of conductor strands in any core is ignored provided they have not pierced the insulation.

19.6 The cord entry to rewirable plugs shall be so shaped as to prevent damage to the cord.

19.6.1 Compliance shall be checked by inspection.

20 Mechanical strength

20.1 Plugs shall have adequate mechanical strength and be so constructed as to withstand such handling as may be expected in normal use.

20.1.1 Compliance shall be checked by the tests given in **20.1.2** and **20.1.3**.

20.1.2 A solid link of stainless steel as shown in Figure 19 is inserted and withdrawn from the fuse clips of the plug 20 times in succession in a normal manner, not in mis-use conditions, at a rate not exceeding 10 per minute. A standard fuse link complying with BS 1362:1973 is then fitted and the appropriate mechanical strength test completed.

20.1.3 Rewirable plugs are fitted with 3-core PVC 1.25 mm^2 flexible cord as given in Table 27 of BS 6500:2000, the terminals and cover screws being tightened with the torque given in Table 3a. Non-rewirable plugs are tested as delivered.

Rewirable plugs with clamp type (screwless) terminals are fitted with 3-core PVC 1.25 mm^2 flexible cord as given in Table 27 of BS 6500:2000. The connection of the conductors shall be made in accordance with the manufacturer's instructions.

The flexible cords attached to plugs are cut to a length of $150 \text{ mm} \pm 5 \text{ mm}$ measured from the nearest edge of the earthing pin, precoiled flexible cords being extended before measurement.

Plugs are tested in the tumbling barrel shown in Figure 20. The barrel is turned at a rate of approximately 5 r/min, (approximately 10 falls per minute).

Table 5 — *Not used.*

Table 6 — Connection of flexible cords

Termination	Conductor insulation colour		
	3-core	2-core colour coded complying with BS 6500:2000	Cords as given in Table 24 of BS 6500:2000
Earthing	Green/yellow	No connection	No connection
Live	Brown	Brown	As supplied
Neutral	Blue	Blue	As supplied

Only one plug is tested at a time. The number of drops is as follows:

- a) rewirable plugs marked BS 1363: 1 000;
- b) non-rewirable plugs marked BS 1363: 2 500;
- c) plugs marked BS 1363/A: 5 000.

After the test the plug shall show no external damage which might affect the safety and no components shall have become detached. The earthing pin terminal screw if any shall remain tight to a torque not less than 70 % of the original tightening torque and current-carrying joints shall not have become loose and shall make satisfactory contact. The sample shall then be checked by inspection, and shall comply with the appropriate test described in Clause 16, and the gauge in accordance with Figure 5 when used in a manner as described in 12.2.1 but with a force not exceeding 20 N.

For the repeat test given in Clause 16, the attached flexible cord is retained without disturbing the terminal connections, but the conductor insulation and sheath are removed only as far as is necessary for the attachment of a 1 000 mm \pm 50 mm length of flexible cord of the same type as that already attached to the plug, the connection being made by means of a connector having a current rating appropriate to that of the flexible cord.

21 Screws, current-carrying parts and connections

21.1 Screwed connections, electrical and otherwise, shall withstand the mechanical stresses occurring in normal use. Screws directly transmitting electrical contact pressure shall screw into metal. Screws shall not be of metal which is soft and liable to creep.

Screws shall not be of insulating material if their replacement by a metal screw would affect the safety or performance requirements of the plug.

Contact pressure in electrical connections within the plug and between the plug and the cable or flexible cord connected to it shall not be transmitted through insulating material other than ceramic, pure mica or other material with characteristics no less suitable, unless there is sufficient resiliency in the metallic parts to compensate for any possible shrinkage or yielding of the insulating material.

NOTE The suitability of the material is considered in respect of the stability of the dimensions under all conditions of normal use especially in view of shrinking, ageing or cold flow of the insulating part.

21.1.1 Compliance shall be checked by inspection and, for screws and nuts which are intended to be tightened during installation, or use, or during replacement of the fuse link by the following test.

The screw is tightened and loosened as follows:

- a) 10 times for screws in engagement with a thread of insulating material, the screw being completely removed and replaced each time;
- b) five times for nuts and other screws.

When testing terminal screws and nuts a 1.5 mm² flexible conductor is placed in the terminal of plugs. The conductor is moved each time the screw is loosened. The test is made by means of a suitable test screwdriver, applying a torque as given in Table 3a.

During the test no damage impairing the further use of the screwed connection shall occur.

NOTE It is essential that the shape of the blade of the test screwdriver suits the head of the screw being tested and that the screw is not tightened in jerks.

For clamp type (screwless) terminals compliance shall be checked by inspection and the test given in Clause 25.

21.2 Thread-cutting and/or thread-forming screws shall not be used for the making of current-carrying or earth continuity connections.

Screws which make a mechanical connection between different parts of the plug shall be locked against loosening, if the connection carries current.

Rivets used for current-carrying or earth continuity connections shall be locked against loosening, if these connections are subject to torsion in normal use which is likely to loosen the connection.

21.2.1 Compliance shall be checked by inspection and by manual test.

NOTE 1 Spring washers and the like may provide satisfactory locking.

NOTE 2 For rivets a non-circular shank or an appropriate notch may be sufficient.

21.3 A_4 Current carrying parts (except for live and neutral plug pins) and earthing plug pins A_4 shall be of brass, copper, phosphor-bronze or other metal at least equivalent with regard to its conductivity, resistance to abrasion and resistance to corrosion.

NOTE This requirement does not apply to screws, nuts, washers, clamping plates and similar parts of terminals.

21.3.1 Compliance shall be checked by inspection and by the relevant tests described in **10.1**, Clause **16** and Clause **24**.

22 Resistance to heat

22.1 Plugs shall be resistant to heat.

22.1.1 Compliance shall be checked by the test described in **22.1.2** or **22.1.3**.

22.1.2 Plug samples are kept for 60^{+5}_0 min in a heating cabinet maintained at $70\text{ }^\circ\text{C} \pm 5\text{ }^\circ\text{C}$. During the test they shall not undergo any change impairing their further use and the sealing compound shall not flow to such an extent that live parts are exposed.

NOTE A slight displacement of the sealing compound should be disregarded.

After the test the plug shall still satisfy the tests described in **9.2.1** and **15.1.3**.

22.1.3 Plugs with external parts of resilient material, e.g. thermoplastics, rubber, are subjected to a pressure test by means of an apparatus similar to that shown in Figure 23, the test being made in a heating cabinet at a temperature of $70\text{ }^\circ\text{C} \pm 5\text{ }^\circ\text{C}$.

The plug is clamped between the jaws in such a way that these press against it in the area where it is gripped in normal use, the centreline of the jaws coinciding as nearly as possible with the centre of this area.

The force applied through and including the effect of the jaws is 20^{0}_{-1} N.

After 60^{+5}_0 min the jaws are removed and the plugs shall satisfy the tests described in **15.1.2b)1)** and **15.1.3** and shall comply with the gauge given in Figure 5 when used in a manner as described in **12.2.1**.

22.2 Parts of insulating material shall be sufficiently resistant to heat having particular regard for their location and function in the complete plug.

22.2.1 Compliance shall be checked as follows:

- a) parts of ceramic material are deemed to comply without testing;
- b) external parts of plugs tested according to **22.1.3**, are deemed to comply without further testing;
- c) all other parts of insulating material including ISOD if fitted shall be subjected to the ball pressure test A_4 in accordance with BS EN 60695-10-2:2003. A_4

The test is made in a heating cabinet maintained at a temperature of $75\text{ }^\circ\text{C} \pm 5\text{ }^\circ\text{C}$.

A_4 Text deleted A_4

23 Resistance to abnormal heat, fire and tracking

23.1 General

Plugs shall be proof against abnormal heat, fire and tracking.

23.1.1 Compliance shall be checked by the test described in **23.2**.

The tests shall not be made on parts of ceramic material or metal.

23.2 Glow-wire test

The test is performed according to A_4 BS EN 60695-2-11:2001 A_4 and at the test temperature given in Table 7.

Table 7 — Application of glow-wire test

Part	Temperature of glow-wire °C
Parts necessary to retain live parts in position including ISOD	750 ± 10
Parts not necessary to retain live parts in position (although they may be in contact with live parts)	650 ± 10

NOTE If the test specified is required to be made at more than one place on the same specimen, it is essential that care is taken to ensure that any deterioration caused by previous test does not affect the result of the test to be made.

Ⓐ Small parts (see 3.31), parts of insignificant mass (see 3.30), parts unlikely to be subjected to abnormal heat and parts whose failure to pass these tests would not materially affect the safety of the plug are not subjected to this glow-wire test. Ⓐ

The glow-wire test is applied to ensure that an electrically heated test wire under defined test conditions does not cause ignition of insulating parts or to ensure that a part of insulating material, which might be ignited by the heated test wire under defined conditions, has a limited time to burn without spreading fire by flame or burning parts or droplets falling down from the tested part onto a pinewood board covered with tissue paper.

The test specimen shall be either a complete plug or, if the test cannot be made on a complete plug, a suitable part may be cut from one for the purpose of the test.

The test shall be made on one specimen.

In case of doubt, the test shall be repeated on two further specimens.

The test shall be made applying the glow-wire once.

The specimen shall be positioned during the test in the most unfavourable position of its intended use (with the surface tested in a vertical position).

The tip of the glow-wire shall be applied to the specified surface of the specimen taking into account the conditions of the intended use under which a heated or glowing element may come into contact with the specimen.

The specimen shall be regarded as having passed the glow-wire test if:

- a) there is no visible flame and no sustained glowing; or
- b) flames and glowing at the specimen extinguish within 30 s after the removal of the glow-wire.

There shall be no ignition of the tissue paper nor scorching of the board.

24 Resistance to excessive residual stresses and to rusting

24.1 Press-formed or similar current-carrying parts of copper alloy containing less than 80 % of copper shall be resistant to failure in use due to stress corrosion.

24.1.1 Compliance shall be checked by the following test.

The sample is degreased in a suitable alkaline degreasing solution or organic solvent, then immersed in an aqueous solution of mercurous nitrate containing 10 g of $\text{Hg}_2(\text{NO}_3)_2$ and 10 ml of HNO_3 (relative density 1.42) per litre of solution for 30 ± 1 min at a temperature of $20 \text{ }^\circ\text{C} \pm 5 \text{ }^\circ\text{C}$.

NOTE Attention is drawn to the fact that due precautions should be taken when using these liquids as they are toxic.

After the treatment the sample is washed in running water, any excess mercury wiped off, and the sample is immediately visually examined.

There shall be no cracks visible with normal or corrected vision without additional magnification.

24.2 Ferrous parts, the rusting of which might cause the plug to become unsafe, shall be adequately protected against rusting.

24.2.1 Compliance shall be checked by the following test.

The sample is degreased in a suitable alkaline degreasing solution or organic solvent, the parts are then immersed for $10 \text{ min} \pm 0.5 \text{ min}$ in a 10 % solution of ammonium chloride in water at a temperature of $20 \text{ }^\circ\text{C} \pm 5 \text{ }^\circ\text{C}$.

Without drying but after shaking off any drops, the parts are placed for $10 \text{ min} \pm 0.5 \text{ min}$ in a box containing air saturated with moisture at a temperature of $20 \text{ }^\circ\text{C} \pm 5 \text{ }^\circ\text{C}$. After the parts have been dried for at least 10 min in a heating cabinet at a temperature of $100 \text{ }^\circ\text{C} \pm 5 \text{ }^\circ\text{C}$ their surfaces shall show no signs of rust.

NOTE 1 Traces of rust on sharp edges and any yellowish film removable by rubbing should be ignored.

NOTE 2 For small helical springs and the like, and for parts exposed to abrasion, a layer of grease may provide sufficient protection against rusting. Such parts are only subjected to the test if there is doubt about the effectiveness of the grease film and the test should then be made without previous removal of the grease.

25 Electrical and thermal stress on clamp type (screwless) terminals

25.1 Clamp type (screwless) terminals shall pass the electrical and thermal stresses occurring in use.

25.1.1 Compliance shall be checked by the following tests.

The rewirable plug shall be wired and mounted for test in accordance with Clause 16. The ambient temperature condition specified in 5.1 shall apply. The plug shall be fitted with a calibrated link for the tests.

A test current of $14 \text{ A} \pm 0.4 \text{ A}$ shall be passed through the plug and cord combination for a period of $60 \text{ min} \pm 2 \text{ min}$, after which the plug and cord combination shall be allowed to cool naturally for a period of $60 \text{ min} \pm 2 \text{ min}$. The test cycle of 60 min “on” and 60 min “off” shall be repeated a further 199 times. During the test, the calibrated link is replaced during the “off” period of every 48th consecutive cycle from the commencement of the test by a new link having characteristics known to be within calibration limits. The link is to be replaced without disturbing the terminals or conductor terminations in so far as this is possible.

At the conclusion of the final cycle and without disturbance, the plug shall be subjected to a temperature rise test in accordance with Clause 16. The measured temperature rise values shall not exceed those values given in Table 4.

After the test, inspection by normal or corrected vision, without additional magnification, shall show no changes evidently impairing further use, such as cracks, deformation, or the like.

A4 26 Overload tests

26.1 Plugs shall withstand overload currents, which could occur due to overload, without creating a risk of contact with live parts.

26.1.1 Compliance shall be checked by the tests given in 26.1.2 to 26.1.4. The test arrangement shall be as described in 16.1 except no thermocouples or pin spacers shall be used.

NOTE Owing to the high temperatures which can be expected during these tests, laboratories are advised to use separate test cabinets for these tests.

26.1.2 The plug shall be fitted with a fuse link complying with BS 1362 with a rating as marked on the plug. The plug shall then be subjected to a test current of 1.6 times the rating of the fuse for 60 min or until the fuse operates (if less than 60 min). Immediately afterwards, the checks specified in 26.1.4 shall be made.

26.1.3 The plug shall be fitted with a fuse link complying with BS 1362 with a rating as marked on the plug. The plug shall then be subjected to a test current of 1.9 times the rating of the fuse for 30 min or until the fuse operates (if less than 30 min). Immediately afterwards, the checks specified in 26.1.4 shall be made.

26.1.4 Each plug shall be checked for compliance with 9.1, 12.6.1a), 12.6.1b) and 12.11.1, except that the tests shall be performed at ambient temperature. Deterioration which does not compromise access to live parts (e.g. discolouring, distortion) shall be deemed to be acceptable. **A4** **C1** Inspection shall not reveal any damage to the plug which would impair its safety within the requirements of this part of BS 1363. **C1**

Annex A (normative)**The construction and calibration of a calibrated link****A.1 Construction**

The calibrated link (see Figure 28) shall employ the following components used to produce fuses complying with BS 1362:1973:

- a) ceramic body (as standard);
- b) filling (as standard);
- c) end caps (modified standard cap as shown in Figure 28a).

The resistive element shall be of copper nickel wire having a resistivity value between $44 \mu\Omega\cdot\text{cm}$ and $49 \mu\Omega\cdot\text{cm}$. The overall length shall be $25.4^{+0.8}_{-0.4}$ mm and the diameter such as to allow a small reduction in the cross-sectional area to adjust the watts loss to the required value. The ends are turned down so that the distance between the shoulders so formed shall be $25.4^{+0.8}_{-0.4}$ mm less twice the end cap end wall thickness “*t*” [see Figure 28b)].

The resistive element shoulders shall be firmly butted to the inside faces of the end caps and soldered using a tin silver solder, grade 96S, as specified in BS 219:1977. The assembly thus formed [see Figure 28c)] shall be checked for watts loss in accordance with A.2. Metal shall then be filed carefully from the resistive element over as long a length as is possible and the assembly rechecked until the desired watts loss is achieved.

One end cap shall then be unsoldered, a standard ceramic body fitted, the cavity filled and the end cap resoldered in position making sure the shoulder of the element is butted to the inside face of the end cap; the ceramic body shall not interfere with this condition. [See Figure 28d).]

The watts loss shall be rechecked in accordance with A.2 and adjusted if necessary.

The resulting calibrated link shall be marked “NOT A FUSE” on the ceramic body and shall dimensionally be in accordance with BS 1362:1973.

A.2 Calibration

The calibration jig shown in Figure 29 is mounted horizontally approximately 25 mm above a wooden board by means of two ceramic pillars. A fine wire thermocouple is attached to the centre of each fuse contact clip, on the outside of the top edge, in such a way that it does not interfere with the contact area. The thermocouples are taken out of the box in slots cut in one end of the jig base, the width of the slots just being sufficient to accept the diameter of the thermocouples. The connection to the jig base shall be by means of PVC insulated single-core copper cables, $0.3 \text{ m} \pm 0.05 \text{ m}$ in length and 2.5 mm^2 cross-section.

The surroundings shall be free from draughts and the ambient air temperature, measured by a suitable thermometer or thermocouple at a horizontal distance of 1 m to 2 m from the standard link, shall be in the range of 15°C to 25°C . The standard link shall be inserted into the clips provided in the calibration jig and the cover replaced. A current of $13 \text{ A} \pm 0.1 \text{ A}$ is then passed continuously through the calibrated link for $60 \text{ min} \pm 5 \text{ min}$. At the end of this time the temperatures measured by the thermocouples are noted, the cover of the jig is then removed and the millivolt drop between the end surfaces of the end caps of the calibrated link is measured whilst it is still carrying the test current.

A.C. shall be used for the calibration.

The calibration is considered to be correct when the following apply:

- a) the product of the measured millivolt drop multiplied by the test current gives a result of $1^{0}_{-0.05} \text{ W}$;
- b) the temperature difference between the fuse contact clips does not exceed 2°C .

Annex B (normative)

Measurement of clearances and creepage distances

The width X specified in Examples 1 to 11 apply to all examples as a function of the pollution degree as given in Table B.1.

Table B.1 — Minimum values of width X

Pollution degree	Minimum values of width X mm
1	0.25
2	1.0
3	1.5

If the associated clearance is less than 3 mm, the minimum groove width may be reduced to one-third of this clearance.

The methods of measuring creepage distances and clearances are indicated in the following Examples 1 to 11. These cases do not differentiate between gaps and grooves or between types of insulation.

The following assumptions are made:

- any recess is assumed to be bridged with an insulating link having a length equal to the specified width X and being placed in the most unfavourable position (see Example 3);
- where the distance across a groove is equal to or larger than the specified width X, the creepage distance is measured along the contours of the groove (see Example 2);
- creepage distances and clearances measured between parts which can assume different positions in relation to each other, are measured when these parts are in their most unfavourable position.

Explanation for Examples 1 to 11

----- clearance
 ===== creepage distance

All dimensions are in millimetres

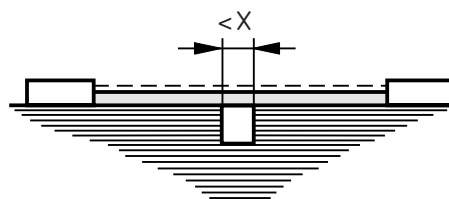

Example 1

Example 1

Condition: Path under consideration includes a parallel- or converging-sided groove of any depth with a width less than "X" mm.

Rule: $\overline{A_4}$ Creepage distance $\overline{A_4}$ and clearance are measured directly across the groove as shown.

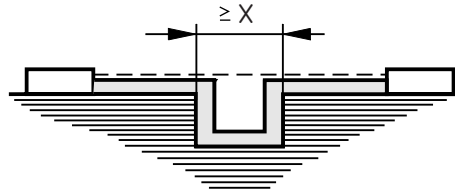

Example 2

Example 2

Condition: Path under consideration includes a parallel-sided groove of any depth and with a $\sqrt{A_4}$ width equal to or greater than $\sqrt{A_4}$ "X" mm.

Rule: Clearance is the "line of sight" distance. Creepage path follows the contour of the groove.

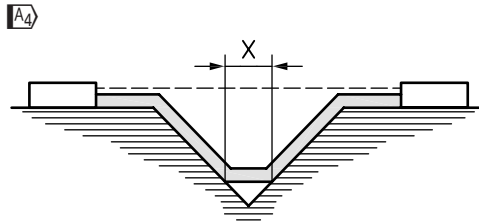

Example 3

Example 3

Condition: Path under consideration includes a V-shaped groove with a width greater than "X" mm.

Rule: Clearance is the "line of sight" distance. Creepage path follows the contour of the groove but "short-circuits" the bottom of the groove by an "X" mm link.

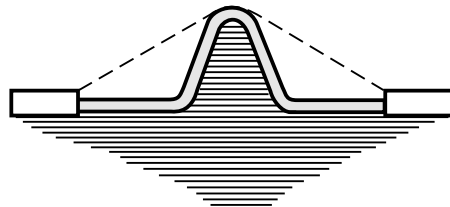

Example 4

Example 4

Condition: Path under consideration includes a rib.

Rule: Clearance is the shortest direct air path over the top of the rib. Creepage path follows the contour of the rib.

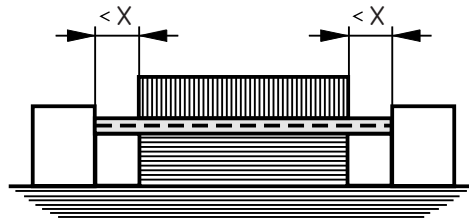

Example 5

Example 5

Condition: Path under consideration includes an uncemented joint with grooves less than “X” mm wide on each side.

Rule: Creepage and clearance path is the “line of sight” distance shown.

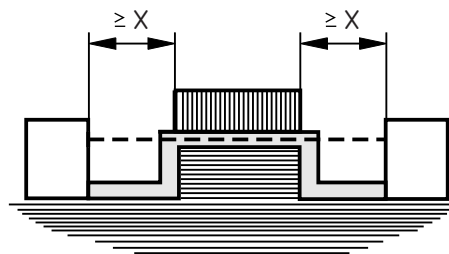

Example 6

Example 6

Condition: Path under consideration includes an uncemented joint with grooves equal to or more than “X” mm wide on each side.

Rule: A_4 Clearance path is the “line of sight” distance. A_4 Creepage follows the contour of the grooves.

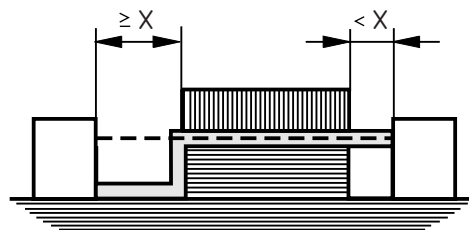

Example 7

Example 7

Condition: Path under consideration includes an uncemented joint with groove on one side less than “X” mm wide and the groove on the other side equal to or more than “X” mm wide.

Rule: Clearance and creepage paths are as shown.

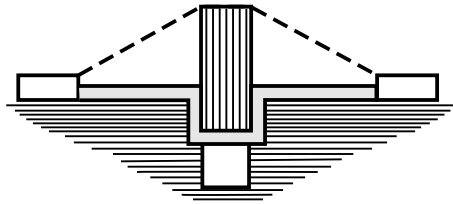

Example 8

Example 8

Condition:

Ⓐ Path under consideration includes a barrier with an uncemented joint. The creepage distance through the uncemented joint is less than the creepage distance over the barrier. Ⓐ

Rule:

Ⓐ Clearance is the shortest direct air path over the top of the barrier. The creepage path follows the contour of the joint. Ⓐ

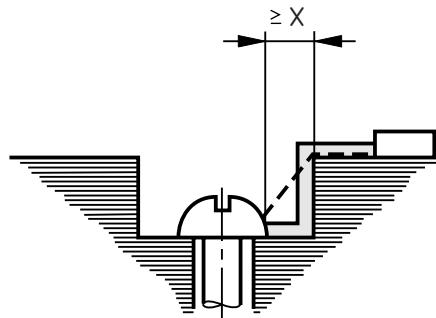
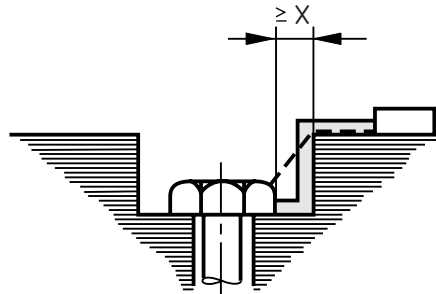

Example 9

Example 9

Condition:

Gap between head of screw and wall of recess wide enough to be taken into account Ⓐ (greater than or equal to "X" mm) Ⓐ.

Rule:

Clearance and creepage distance paths are shown.

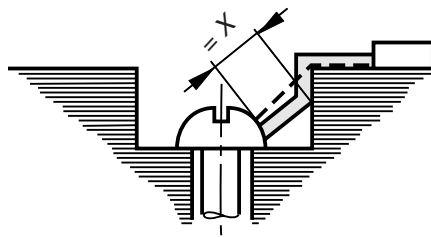
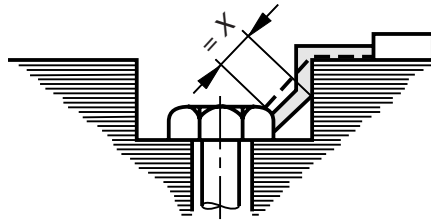

Example 10

Example 10

A4 Condition: Gap between head of screw and wall of recess too narrow to be taken into account (less than "X" mm). **A4**

A4 Rule: Measurement of clearance and creepage distance is from the screw head to the point on the wall which is at a distance equal to "X" mm (as shown). **A4**

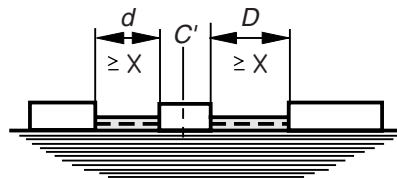

Example 11

Example 11

A4 Condition: Path under consideration includes a floating part, C' , with different sized grooves either side, each greater than or equal to "X" mm. **A4**

A4 Rule: Clearance and creepage distance are both distance $d + D$. **A4**

Annex C (normative)**Determination of the Comparative Tracking Index (CTI) and Proof Tracking Index (PTI)**

A3 The CTI or PTI is determined in accordance with BS EN 60112.

For the purpose of this standard the following applies.

- a) In Clause 5 of BS EN 60112:2003, Test specimen:
 - Note 3 and the last paragraph also apply to PTI;
 - If the surface 15 mm × 15 mm cannot be obtained because of the small dimensions of the PT system then special samples made with the same manufacturing process may be used.
- b) The test solution “A” described in 7.3 of BS EN 60112:2003 shall be used.
- c) In Clause 8 of BS EN 60112:2003, Procedure, either CTI or PTI is determined.
 - CTI is determined in accordance with Clause 11 of BS EN 60112:2003.
 - The PTI test of Clause 10 of BS EN 60112:2003 is performed on five samples at the voltage referred to in 10.1 of BS EN 60112:2003 based on the appropriate creepage distance, material group, pollution degree conditions and on the rated voltage of this standard declared by the manufacturer. **A3**

Annex D (normative)**Relation between rated impulse withstand voltage, rated voltage and Overvoltage Category**

Table D.1 — Rated impulse withstand voltage for **A4 plugs **A4** energized directly from the low voltage mains**

Nominal voltage of the supply system based on IEC 60038 ^a	Voltage line to neutral derived from nominal voltages a.c. or d.c. up to and including	Rated impulse withstand voltage		
		V		
V	V	Overvoltage Category		
		I	II	III
230/400	300	1 500	2 500	4 000

NOTE 1 For more information concerning supply systems see BS EN 60664-1.

NOTE 2 For more information concerning Overvoltage Category see BS EN 60664-1.

NOTE 3 **A4** Plugs **A4** fall into Overvoltage Category III. Parts of **A4** plugs **A4** where appropriate overvoltage reduction is provided fall into Overvoltage Category 1. Energy consuming equipment falls into Overvoltage Category 2.

^a The / mark indicates a four-wire three-phase distribution system. The lower value is the voltage line-to-neutral, while the higher value is the voltage line-to-line.

Annex E (normative)

Pollution degree

The micro-environment determines the effect of pollution on the insulation. The macro-environment, however, has to be taken into account when considering the micro-environment.

Means may be provided to reduce pollution at the insulation under consideration by effective use of enclosures, encapsulation or hermetic sealing. Such means to reduce pollution may not be effective when the PT-system is subject to condensation or if, in normal operation, it generates pollutants itself.

Small clearances can be bridged completely by solid particles, dust and water and therefore minimum clearances are specified where pollution may be present in the micro-environment.

NOTE Pollution will become conductive in the presence of humidity. Pollution caused by contaminated water, soot, metal or carbon dust is inherently conductive.

Degrees of pollution in the micro-environment

For the purpose of evaluating creepage distances and clearances, the following three degrees of pollution in the micro-environment are established.

— Pollution degree 1

No pollution or only dry, non-conductive pollution occurs. The pollution has no influence.

— Pollution degree 2

Only non-conductive pollution occurs except that occasionally a temporary conductivity caused by condensation is to be expected.

— Pollution degree 3

Conductive pollution occurs or dry non-conductive pollution occurs which becomes conductive due to condensation which is to be expected.

Annex F (normative)

Impulse voltage test

The purpose of this test is to verify that clearances will withstand specified transient overvoltage. The impulse withstand voltage test is carried out with a voltage having a 1.2/50 μ S waveform as specified in A_4 BS EN 61180-1:1995, Section 6 A_4 and is intended to simulate overvoltage of atmospheric origin. It also covers overvoltages due to switching of low-voltage equipment.

The test shall be conducted for a minimum of three impulses of each polarity with an interval of at least 1 s between pulses. A_4 There shall be no discharges during the test. Glow discharges without a drop in voltage shall be ignored. A_4

A_4 For solid insulation and for clearances not checked by measurement, the impulse withstand voltage shall be applied between:

a) line and neutral terminals/terminations;

b) line and neutral terminals/terminations connected together and:

1) a sheet of metal foil in contact with the entire accessible external surface;

2) the earthing terminal/termination;

3) any metal part of a cord anchorage; A_4

C_1 c) each switched pole terminal of a switched plug and corresponding plug pin, with the switch contacts open. C_1

NOTE 1 The output impedance of the impulse generator should be not higher than 500 Ω .

A_4 NOTE 2 The expression “discharge” is used to cover the phenomena associated with the failure of insulation under electric stress, which include current flow and a drop in voltage. A_4

The impulse shall have the following characteristics:

- the waveform 1.2/50 μ S for the no load voltage with amplitudes equal to the values given in Table F.1;
- $\text{\textcircled{A4}}$ *Text deleted* $\text{\textcircled{A4}}$

NOTE 3 If the sample is provided with surge suppression, the impulse voltage wave may be chopped but the sample should be in a condition to operate normally again after the test. If the sample is not provided with surge suppression and it withstands the impulse voltage, the waveform will not be noticeably distorted.

Table F.1 — Test voltages for verifying clearances at sea level

Rated impulse withstand voltage \hat{U} kV	Impulse test voltage at sea level \hat{U} kV
0.33	0.35
0.5	0.55
0.8	0.91
1.5	1.75
2.5	2.95
4.0	4.8
6.0	7.3

NOTE 1 When testing clearances, associated solid insulation will be subjected to the test voltage. As the impulse test voltage of Table F.1 is increased with respect to the rated impulse withstand voltage, solid insulation will have to be designed accordingly. This results in an increased impulse withstand capability of the solid insulation.

NOTE 2 The test may be made with the pressure adjusted to the value corresponding to the altitude of 2 000 m (80 kPa) and 20 °C with the test voltage corresponding to the rated impulse withstand voltage. In this case, solid insulation will not be subjected to the same withstand requirements as when testing at sea level.

NOTE 3 Explanations concerning the influencing factors (air pressure, altitude, temperature humidity) with respect to electric strength of clearances are given in BS EN 60664-1.



Annex G (informative)
Specific structure of BS EN 50525 and its derivation from British Standards and from HD 21 and HD 22
 (BS EN 50525-1:2011, National Annex NA)

Part number of BS EN 50525	Short title	Derivation		
		BS	Table No(s)	HD
1	General requirements	(Note 1)	(Note 1)	HD 21.1; HD 22.1
2-11	PVC flexible cables	BS 6500 BS 7919	26, 27, 28, 29 40, 41	HD 21.5; HD 21.12
2-12	Extensible leads	BS 6500	Clause 8	HD 21.10
2-21	Rubber flexible cables	BS 6500 BS 7919	12, 13, 15, 16 10-17, 20, 21, 23, 24	HD 22.4; HD 22.10; HD 22.11; HD 22.12; HD 22.16
2-22	Braided flexible cables	–	–	HD 22.14 (Clause 6)
2-31	PVC conduit wire	BS 6004	4a), 4b), 5, 11a), 11b), 12	HD 21.3; HD 21.7
2-41	Rubber single core – SiR	BS 6007	8, 9, 10	HD 22.3
2-42	Rubber single core – EVA	BS 6007	3, 4, 5, 6, 7	HD 22.7
2-51	PVC sheathed wiring	BS 6004 BS 7919	13 42, 43	HD 21.13
2-71	Tinsel flexible cables	BS 6500	24	HD 21.5 (Clause 2)
2-72	PVC separable flat	–	–	HD 21.11
2-81	Welding cable	BS 638-4	1, 2	HD 22.6
2-82	Lighting chains	–	–	HD 22.8
2-83	SiR flexible	BS 7919	22	HD 22.15
3-11	Halogen-free flexible (T/P)	–	–	HD 21.14
3-21	Halogen-free flexible (X/L)	BS 7919	18, 19	HD 22.13
3-31	Halogen-free single core (T/P)	–	–	HD 21.15
3-41	Halogen-free single core (X/L)	BS 7211	3a), 3b), 4a), 4b)	HD 22.9

NOTE 1 General requirements were given in each relevant BS as appropriate.



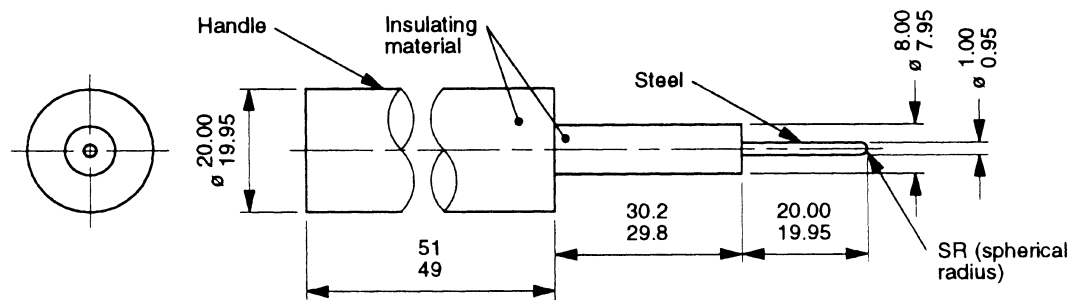

All dimensions are in millimetres.

Figure 1 — Test pin (see Clause 12)

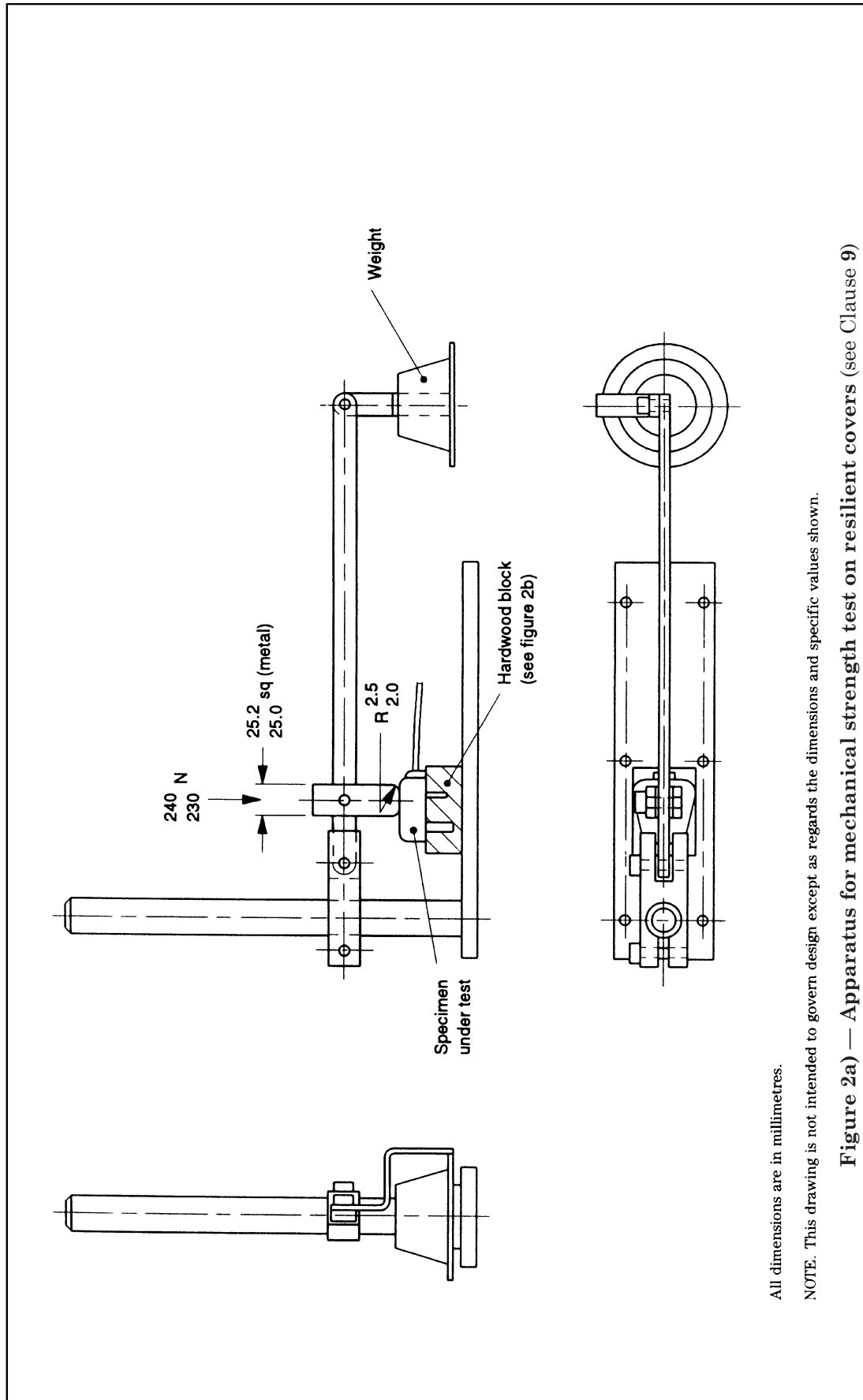

All dimensions are in millimetres.

NOTE. This drawing is not intended to govern design except as regards the dimensions and specific values shown.

Figure 2a) — Apparatus for mechanical strength test on resilient covers (see Clause 9)

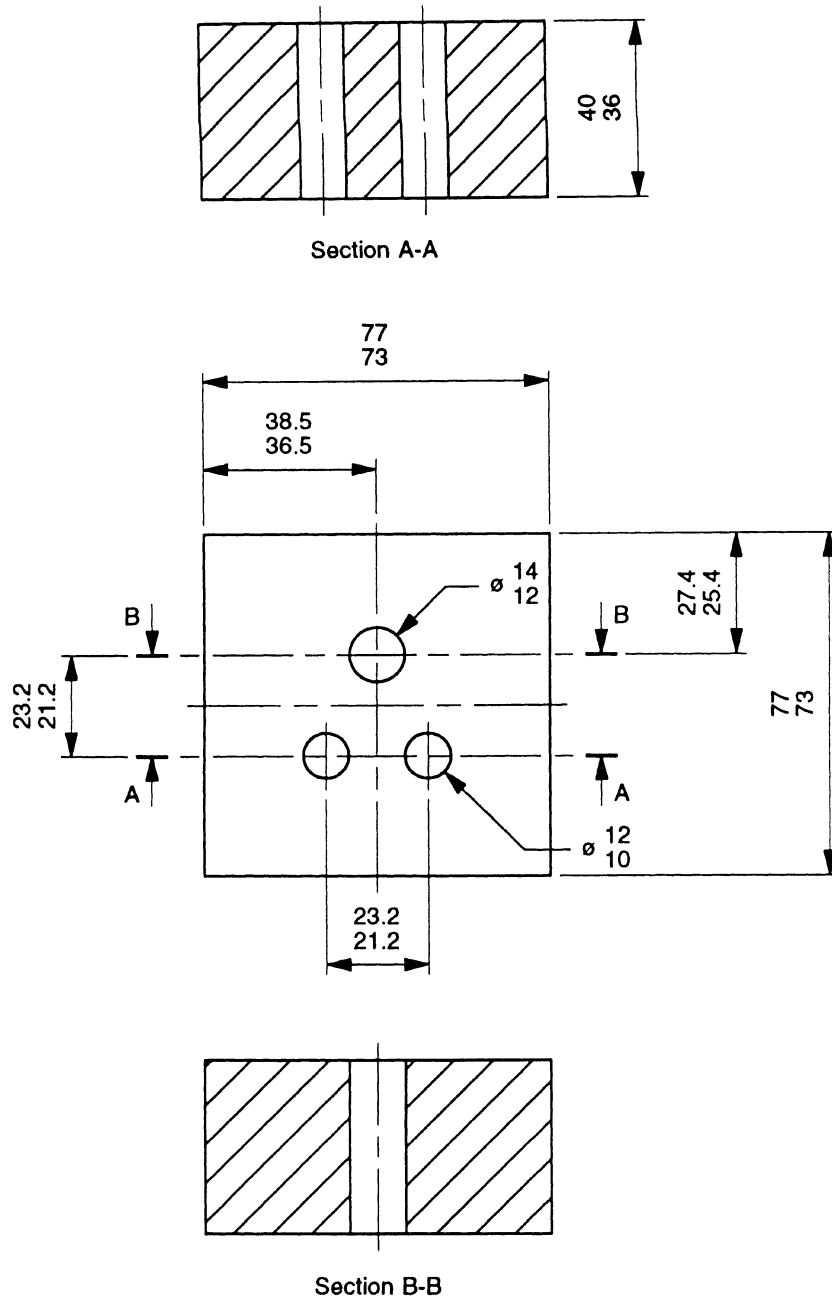

All dimensions are in millimetres.

Figure 2b) — Hardwood block for Figure 2a)

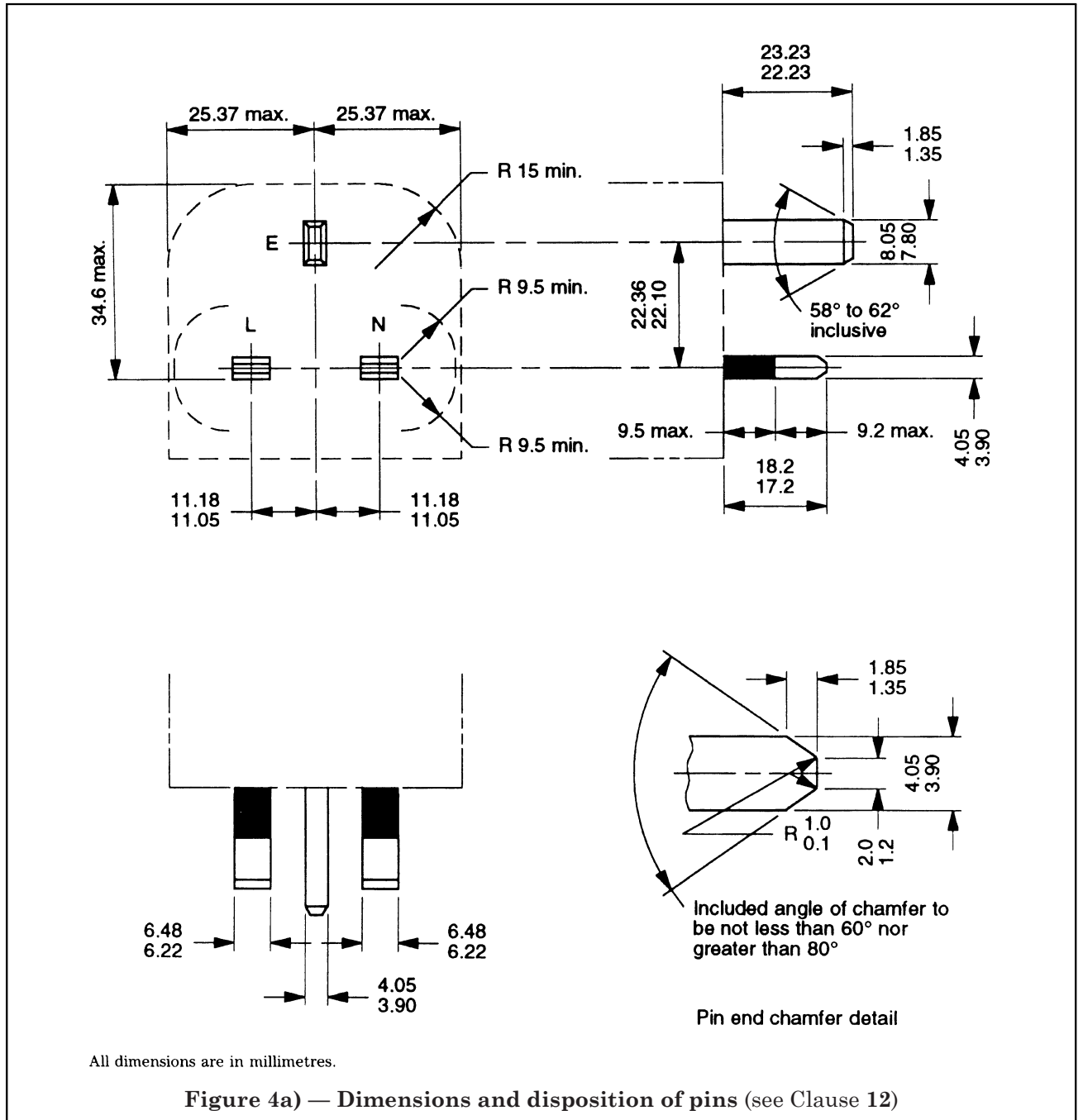

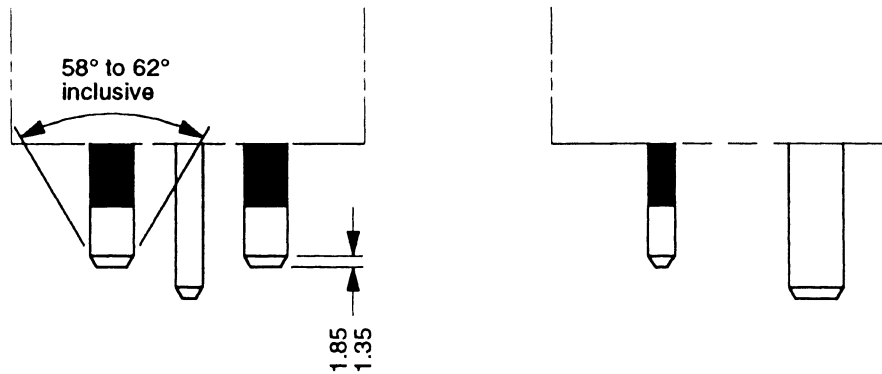

Permitted additional chamfers on L and N pins
(if additional chamfer is used it has to be on both pins)

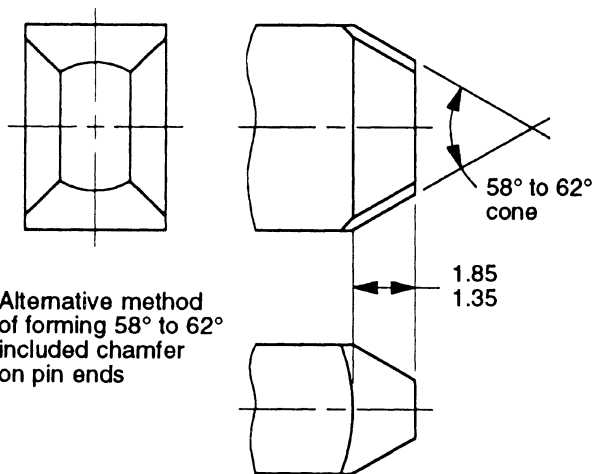

Alternative method
of forming 58° to 62°
included chamfer
on pin ends

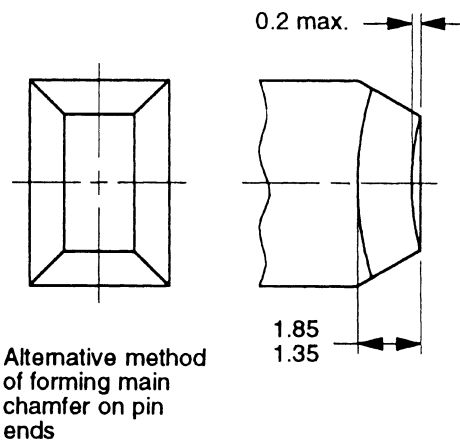

Alternative method
of forming main
chamfer on pin
ends

All dimensions are in millimetres.

NOTE 1. External edges of pins are to be free from burrs or sharp edges and may have a radius not exceeding 1 mm.

NOTE 2. The surfaces of pins are to be flat within the specified tolerances.

Figure 4a) — Dimensions and disposition of pins (see Clause 12) (continued)

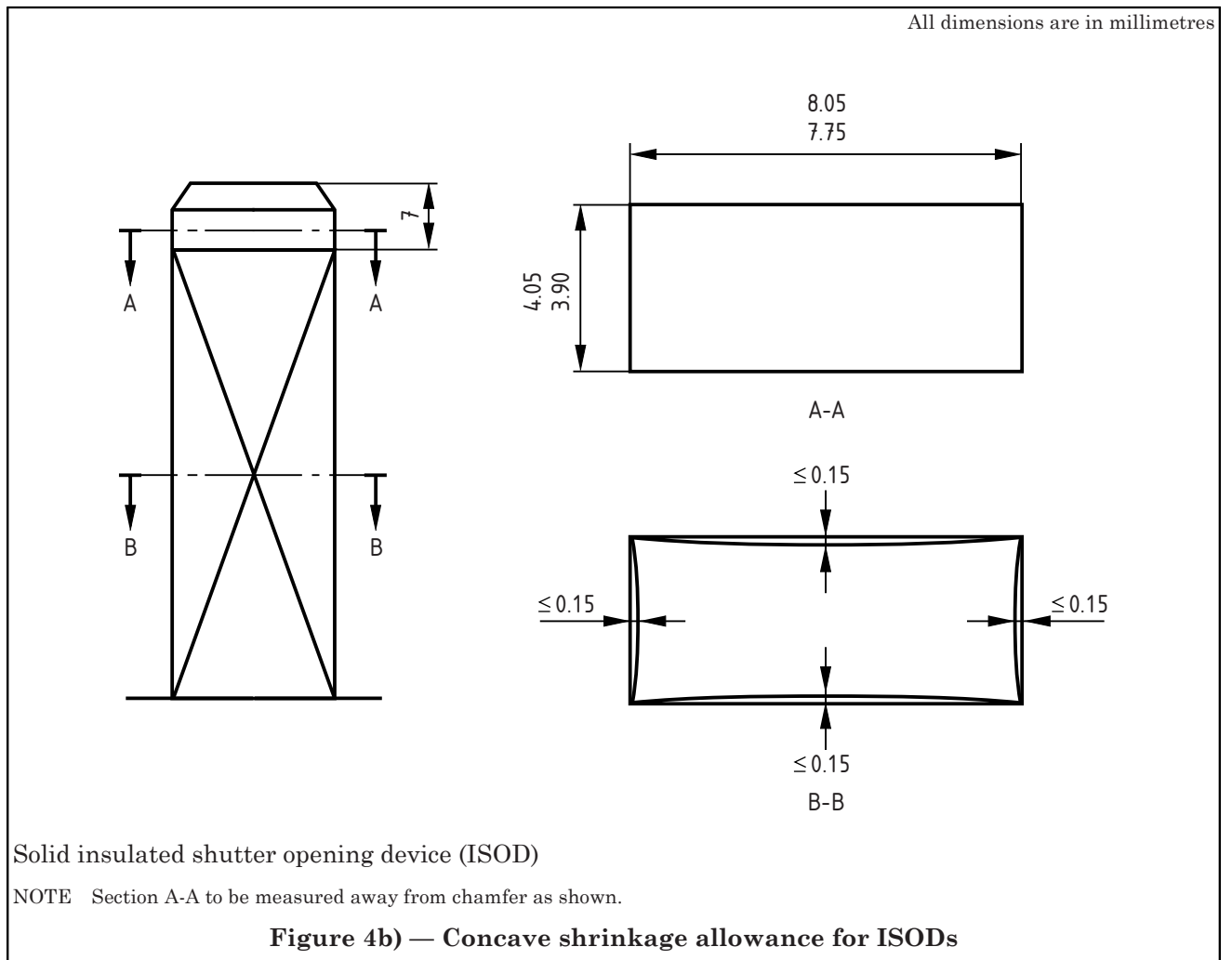

A4

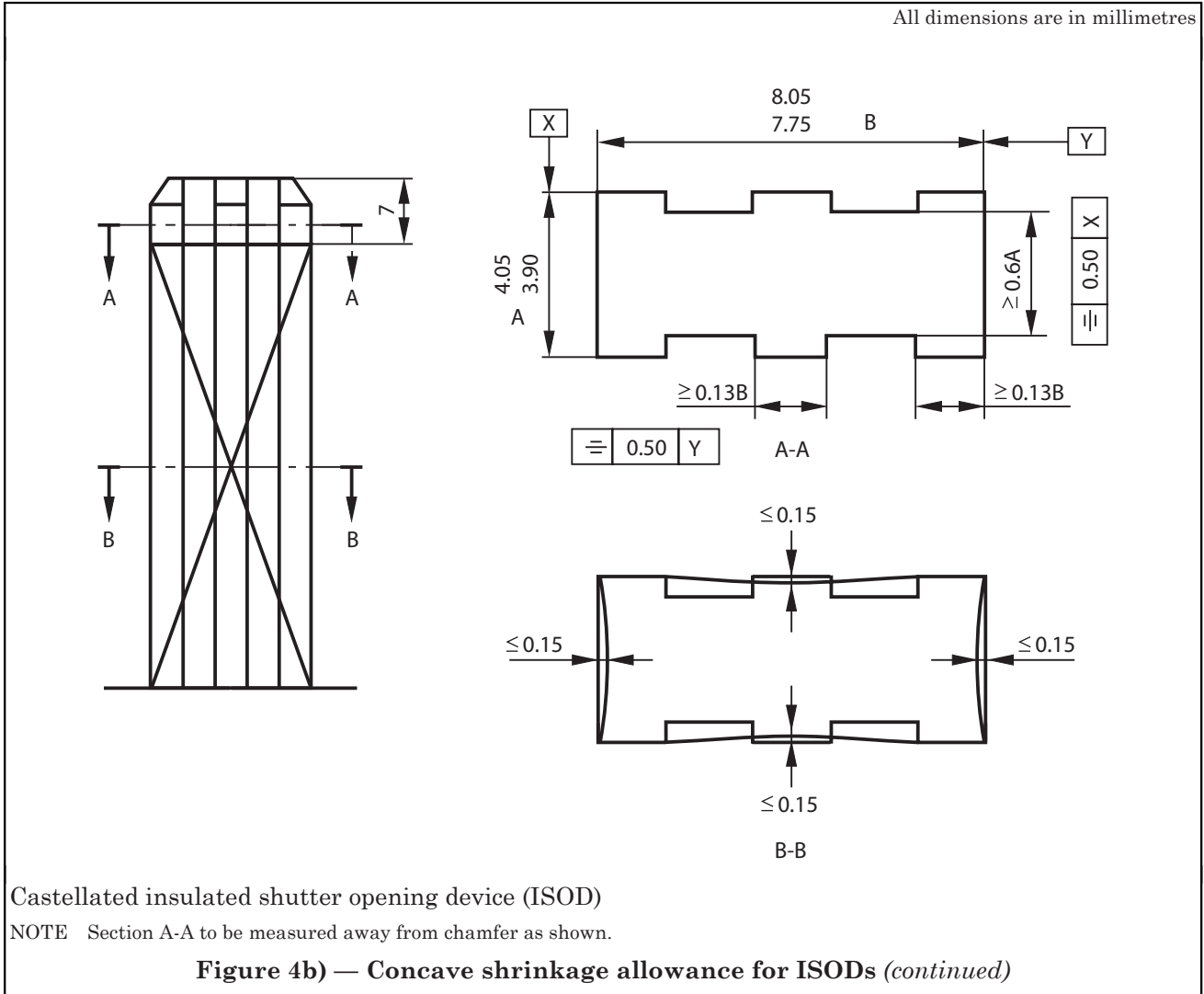

A4

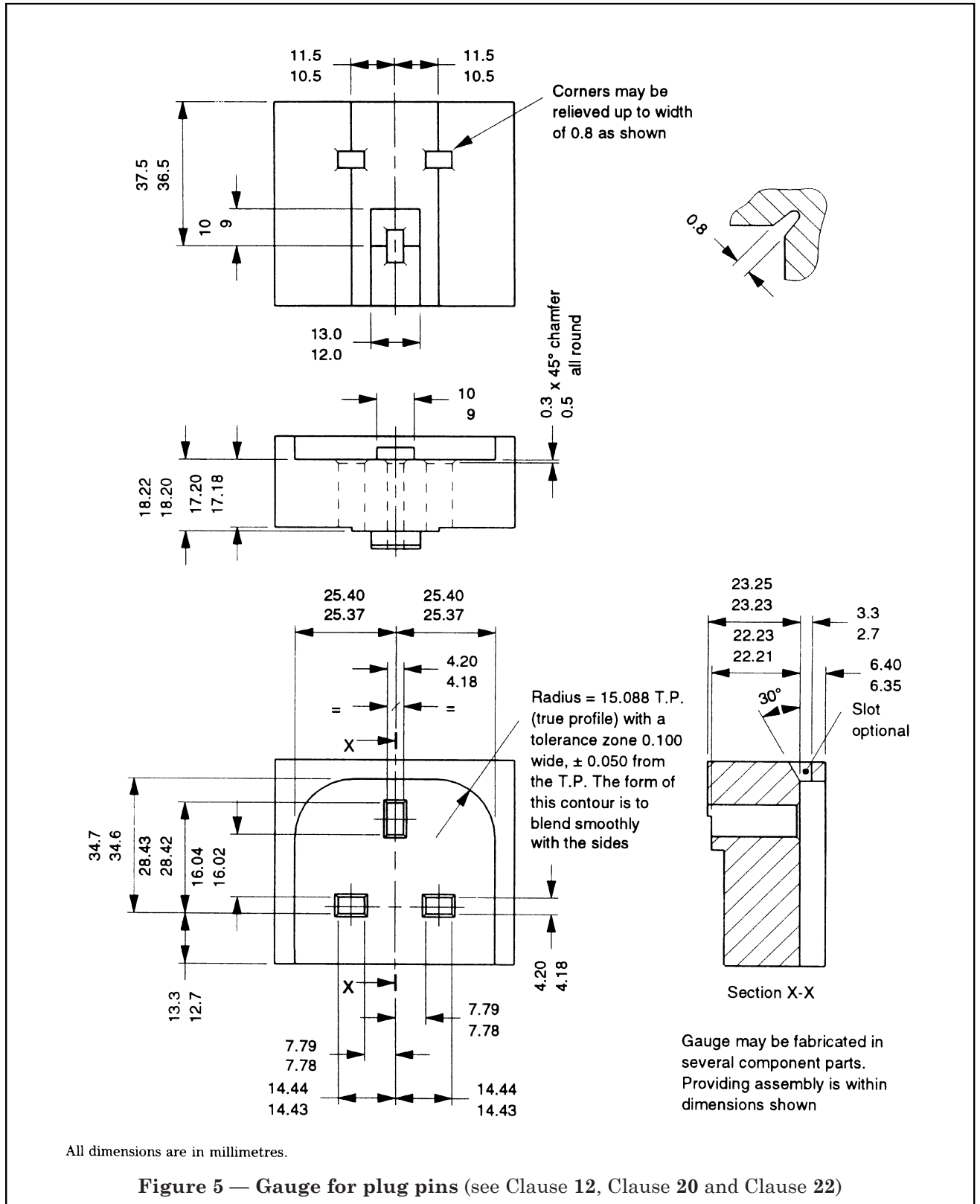

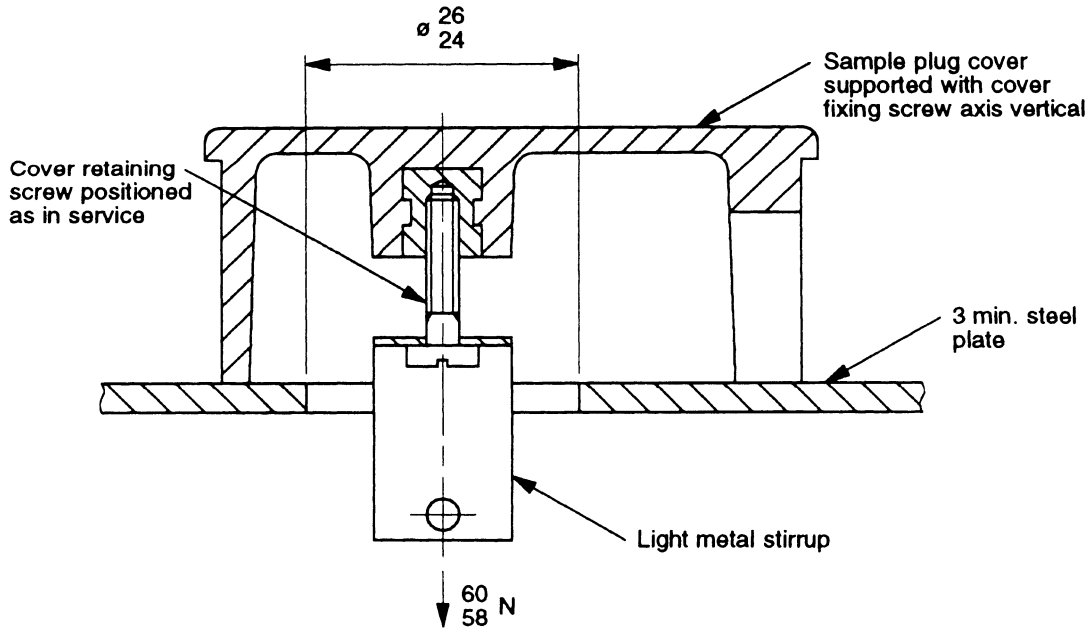

All linear dimensions are in millimetres.

NOTE. This drawing is not intended to govern design, except as regards the dimensions and specific requirements shown.

Figure 6 — Apparatus for testing plug cover fixing screws (see Clause 12)

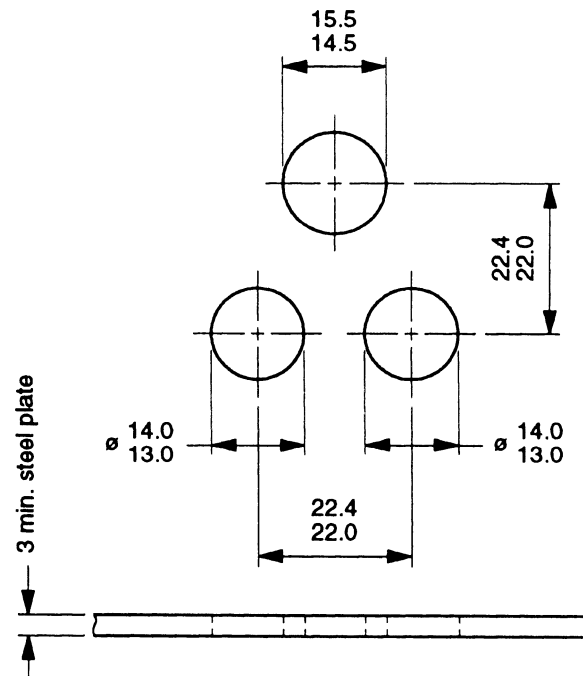

All linear dimensions are in millimetres.

Figure 7 — Mounting plate (see Clause 12)

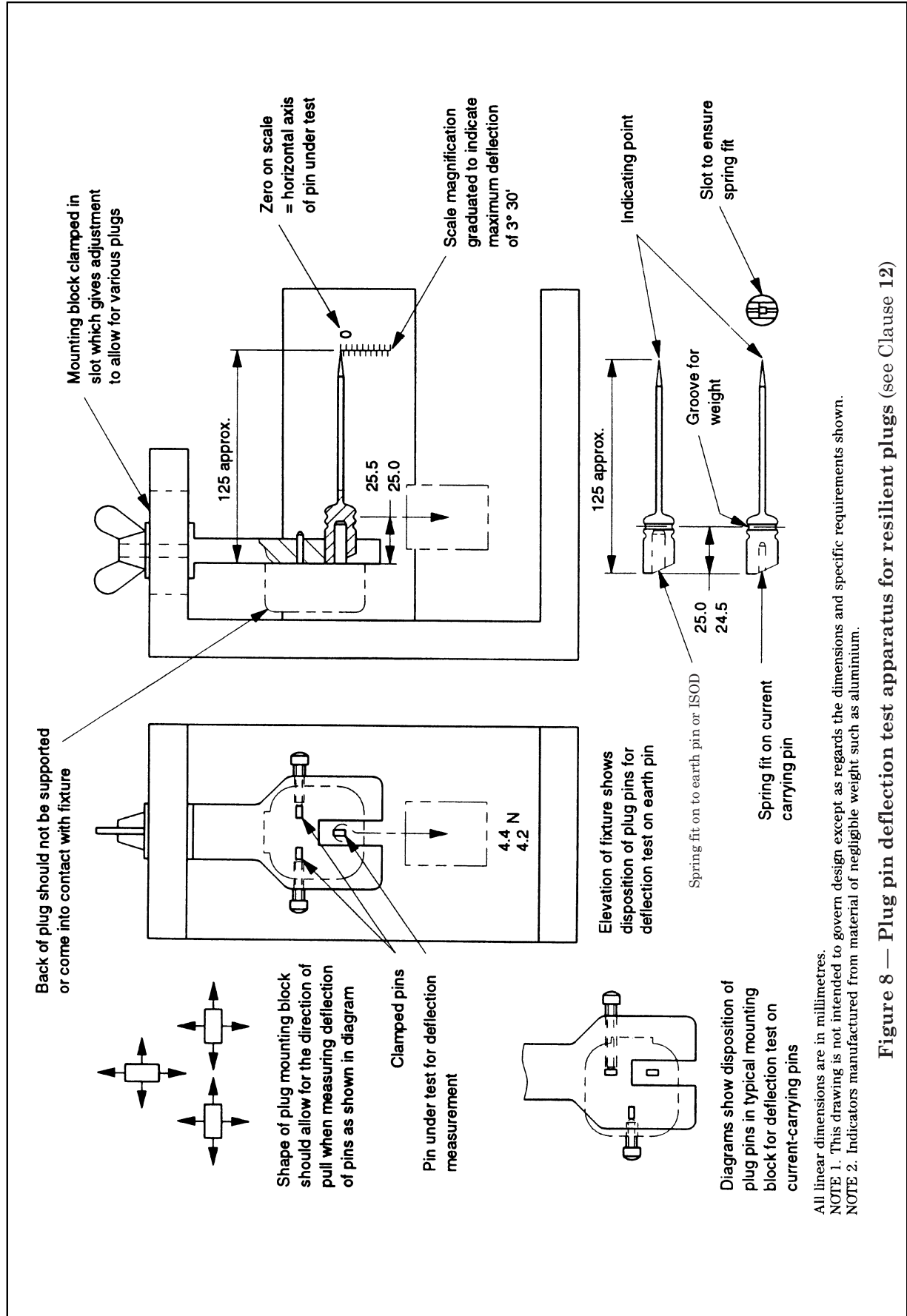

Figure 8 — Plug pin deflection test apparatus for resilient plugs (see Clause 12)

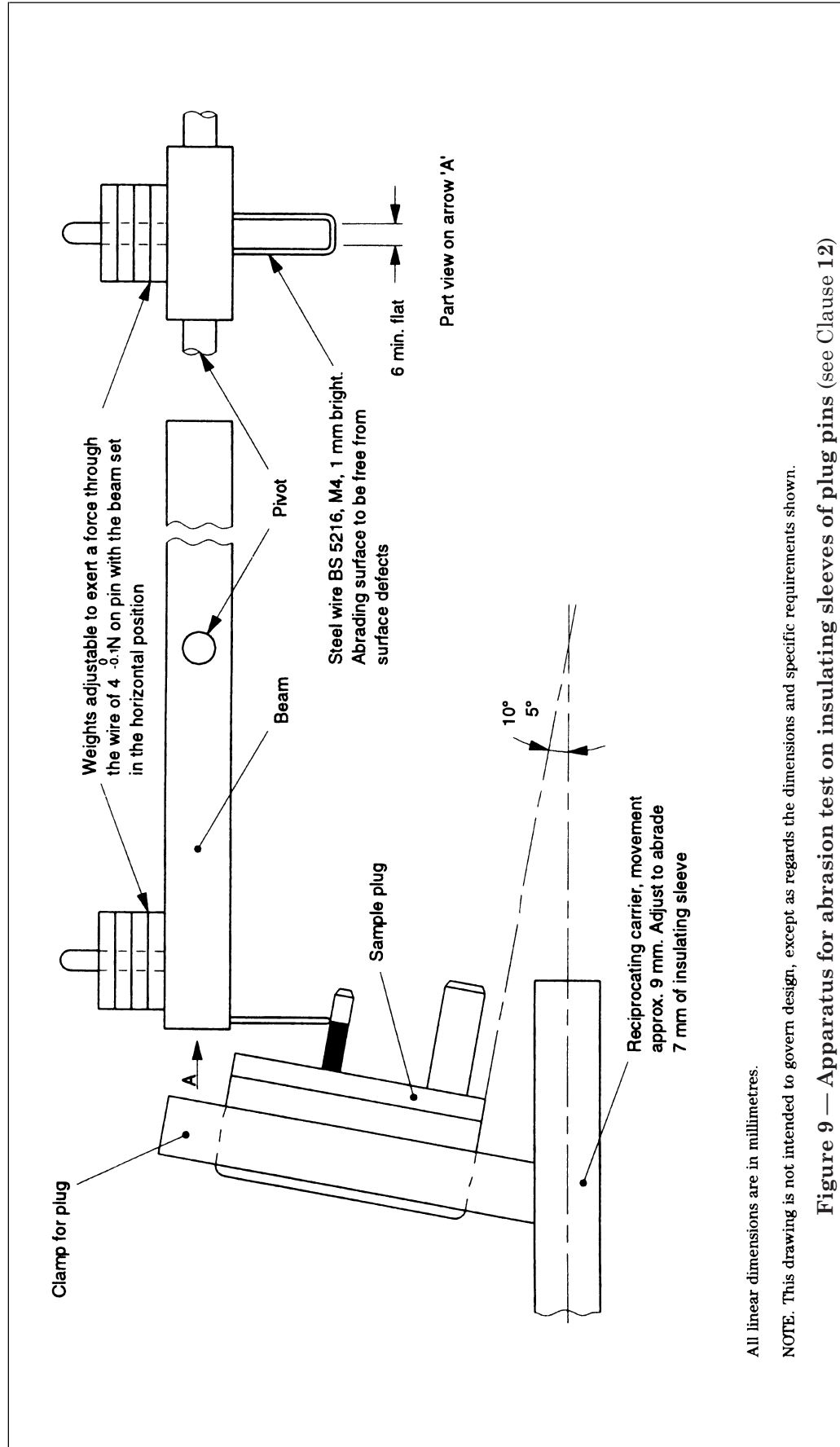
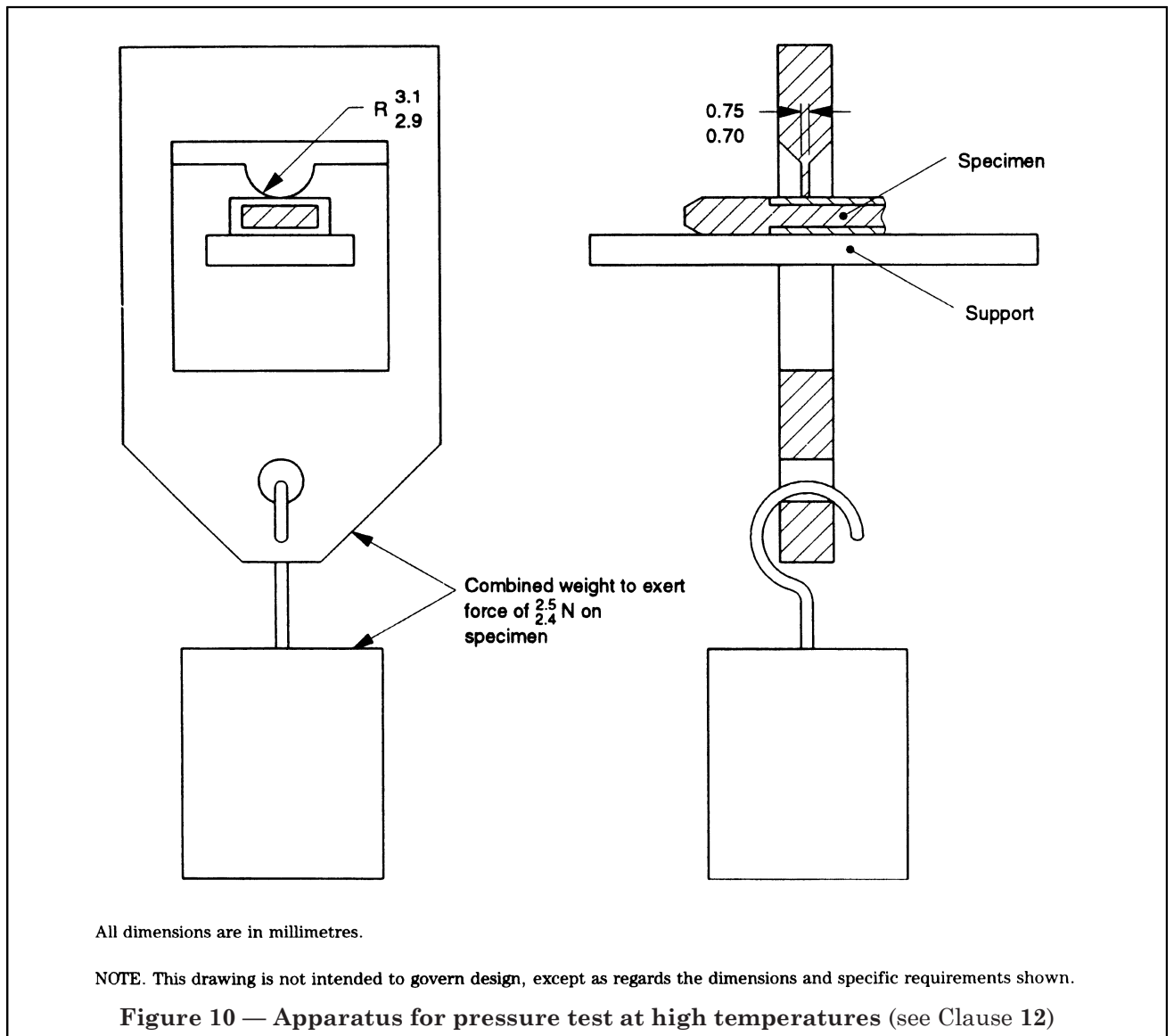
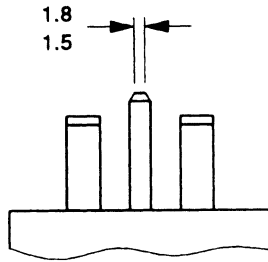

Figure 9 — Apparatus for abrasion test on insulating sleeves of plug pins (see Clause 12)

All linear dimensions are in millimetres.

NOTE. This drawing is not intended to govern design, except as regards the dimensions and specific requirements shown.





		Dimension X	Dimension Y
Pins at max. centres	Min.	11.19	22.37
	Max.	11.21	22.39
Pins at min. centres	Min.	11.01	22.07
	Max.	11.03	22.09

R 15.2 T.P. (true profile) with a tolerance zone 0.1 from the T.P. The form of this contour is to blend smoothly with the sides

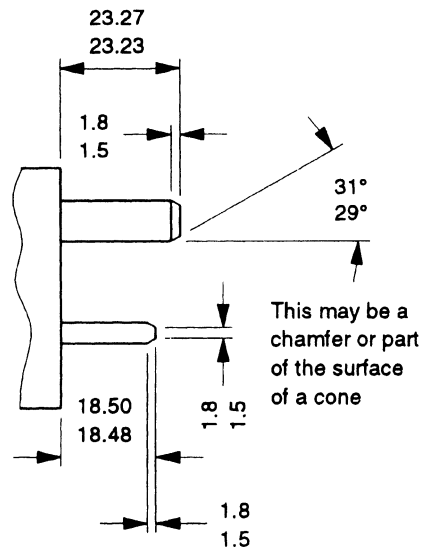
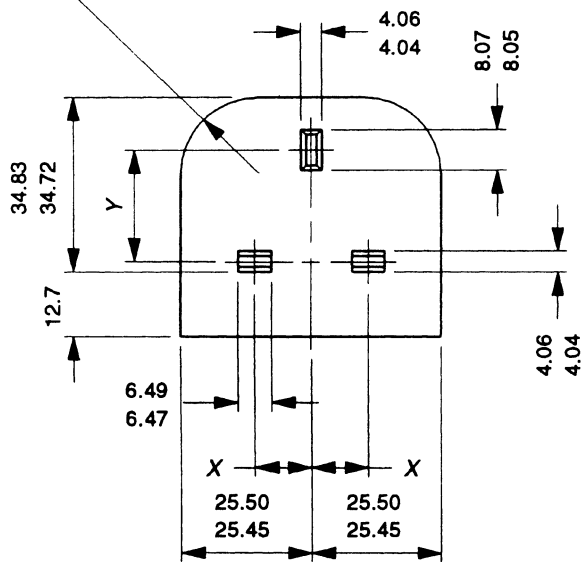

General view

All linear dimensions are in millimetres.

NOTE 1. All sharp edges of the shaped portion of all the pins of the socket-outlet gauge are slightly rounded.

NOTE 2. The surfaces of the gauge in which the pins are mounted are flat to within 0.025 mm.

Figure 11 — GO gauge for socket-outlet [for use when checking Figure 17b)]

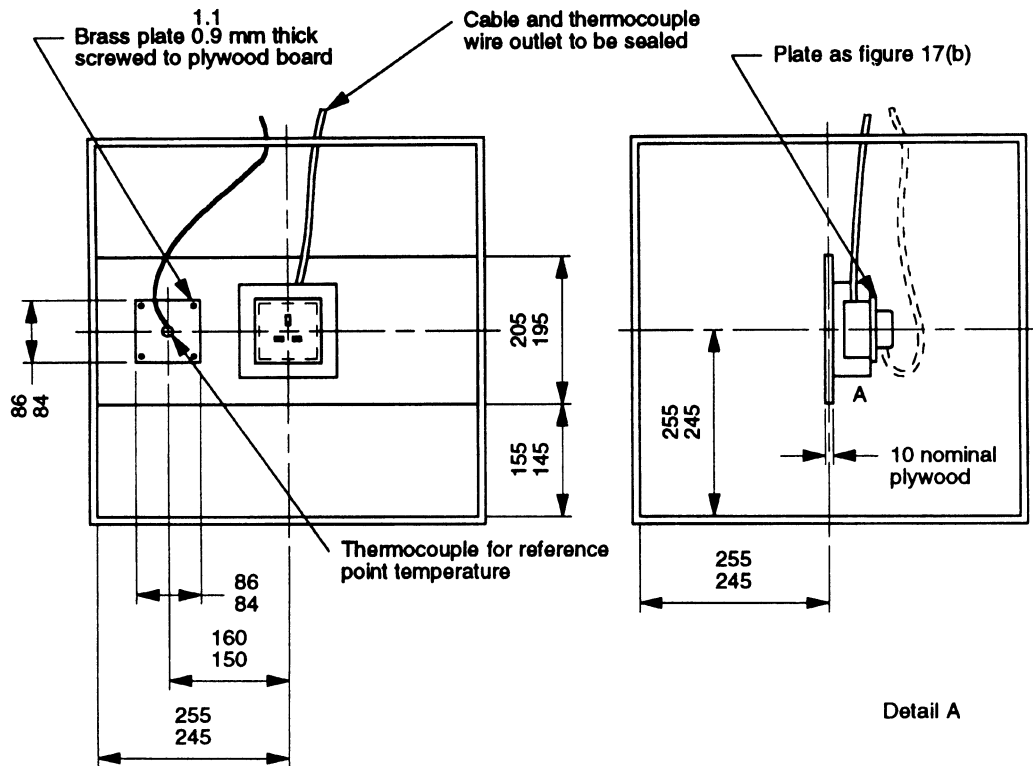

Test cabinet

- Material:** 10 mm nominal plywood.
- Finish:** Internal. Two coats of matt paint. BS 4800 colour no. 08 C 35.
- Dimensions:** Internal. 500 mm x 500 mm x 500 mm with a tolerance of ± 10 mm for each dimension. One wall to be removable to provide access.
- Location:** Minimum clearance from adjacent surfaces, measured horizontally 150 mm on all sides, measured vertically 300 mm above, 500 mm below.

All dimensions are in millimetres.

Mounting box to figure 1(b)
of BS 4662: 1970 35 deep
(nominal)

Front edge recessed
as shown

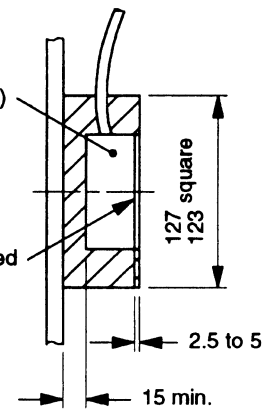
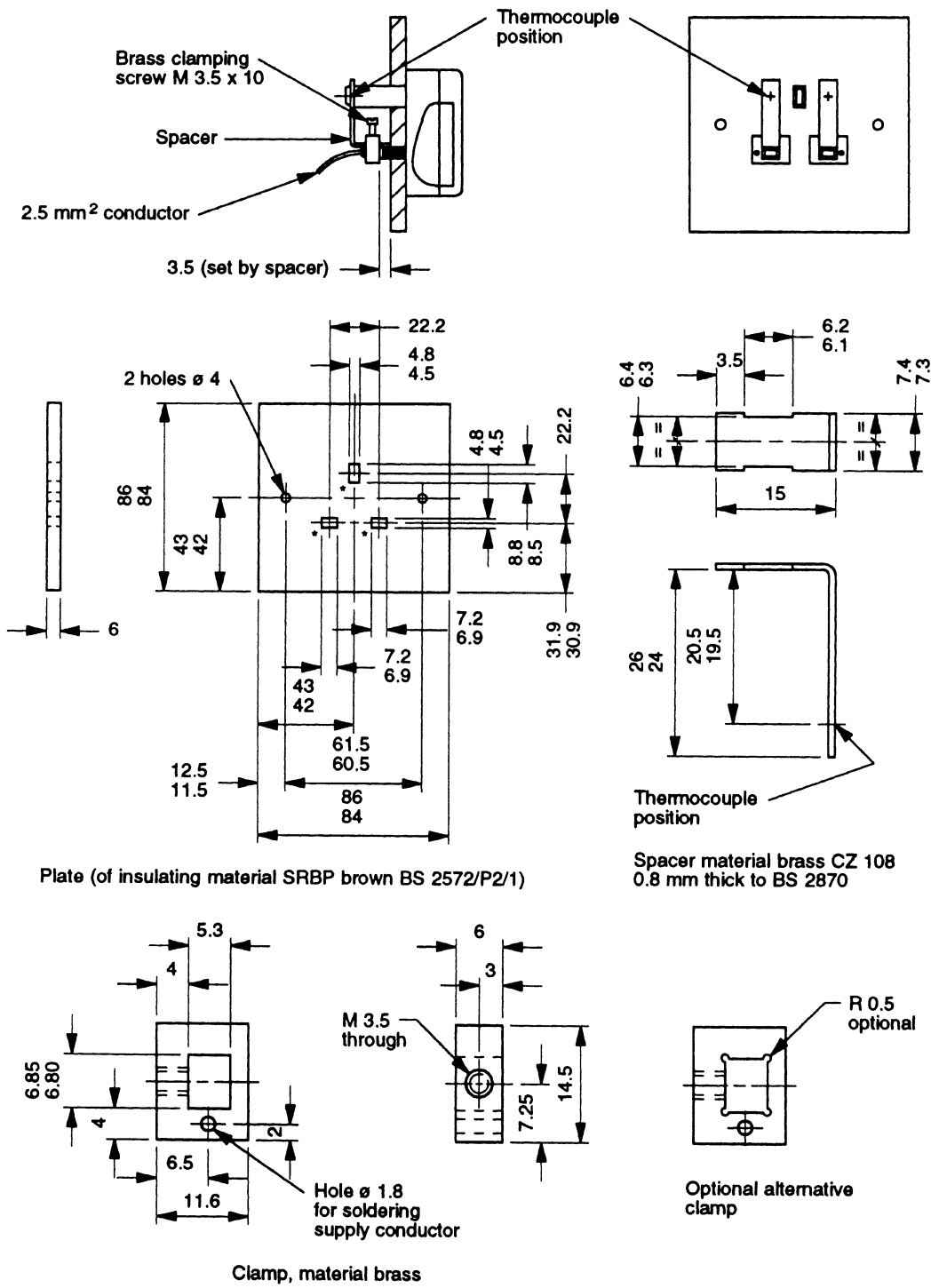

Figure 17a) — Test apparatus for temperature rise test (see Clause 16)



All dimensions are in millimetres.
 *The positional tolerance of the three pin apertures shall be proved by the use of gauges in accordance with figure 11.
 NOTE. Tolerance ± 0.2 mm except where shown.

Figure 17b) — Dummy front plate for temperature rise test (see Clause 16)

Licensed copy: Lee Shau Kee Library, HKUST, Version correct as of 03/01/2015, (c) The British Standards Institution 2013

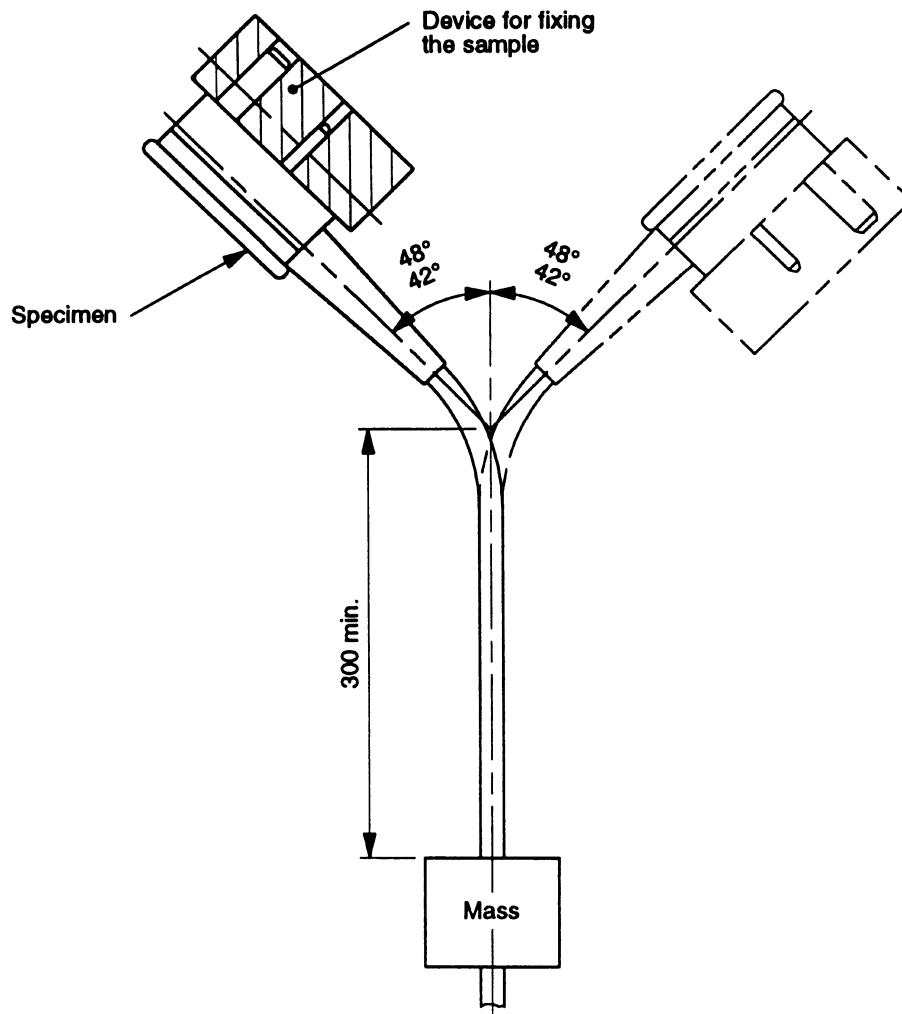

Linear dimension is in millimetres.

NOTE. This drawing is not intended to govern design except as regards the dimensions and specific requirements shown.

Figure 18 — Apparatus for flexing test (see Clause 19)

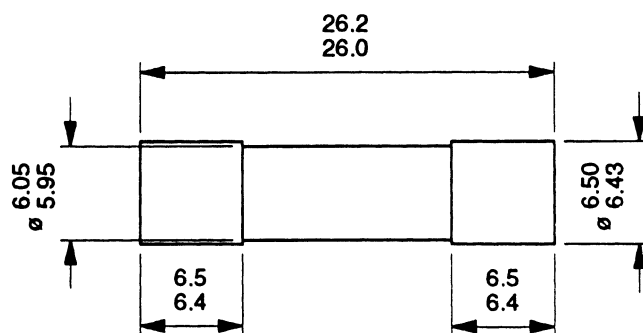

All dimensions are in millimetres.

NOTE. Finish: polished and sharp corners removed.

Figure 19 — Solid link for test on fuse clips (see Clause 20)

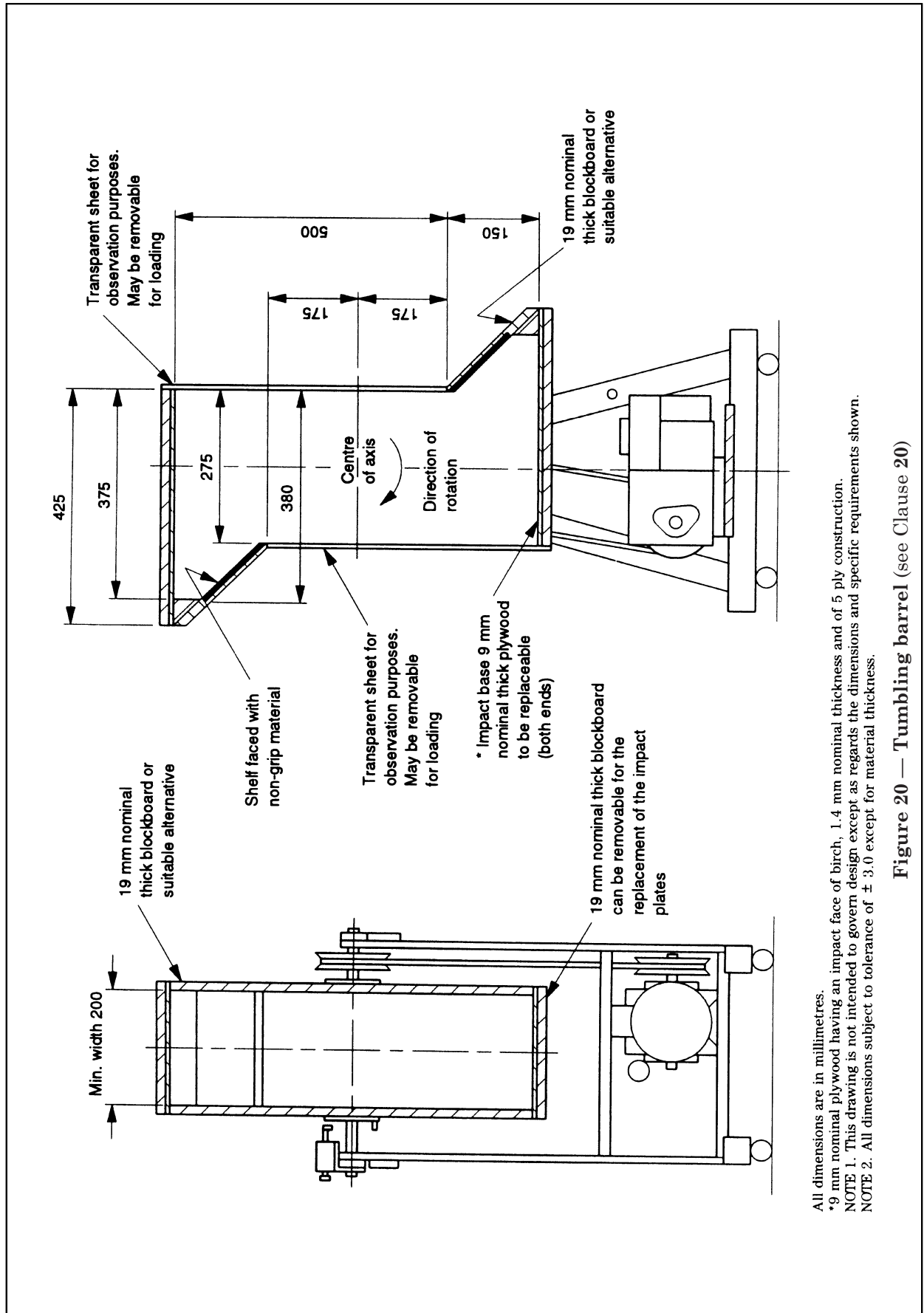
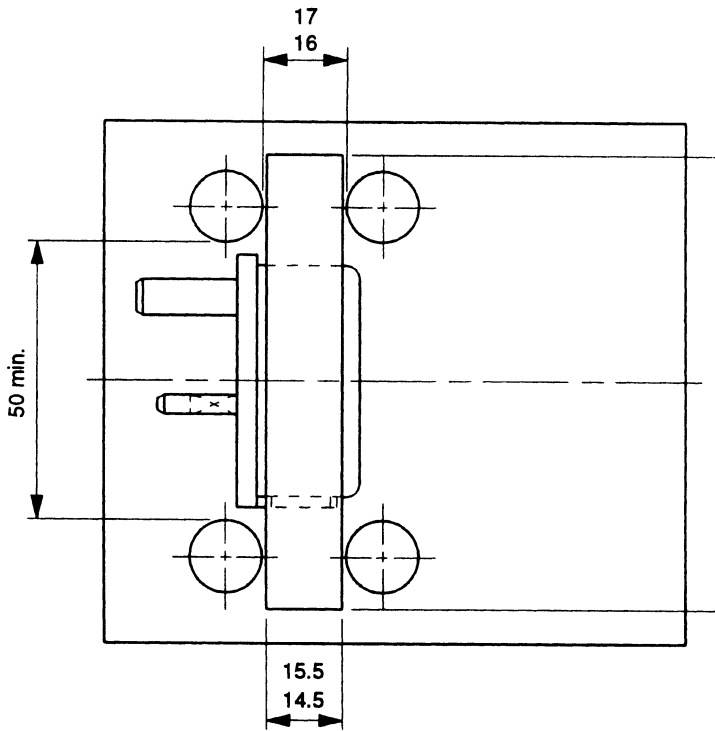
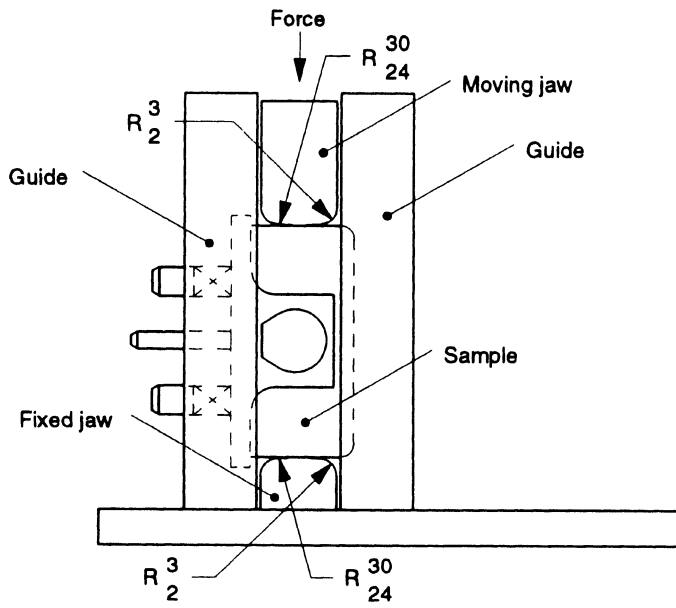

Figure 20 — Tumbling barrel (see Clause 20)



All dimensions are in millimetres.

NOTE. This drawing is not intended to govern design except as regards the dimensions and specific requirements shown.

Figure 23 — Apparatus for pressure test (see Clause 22)

Figure 24 *Figure deleted*

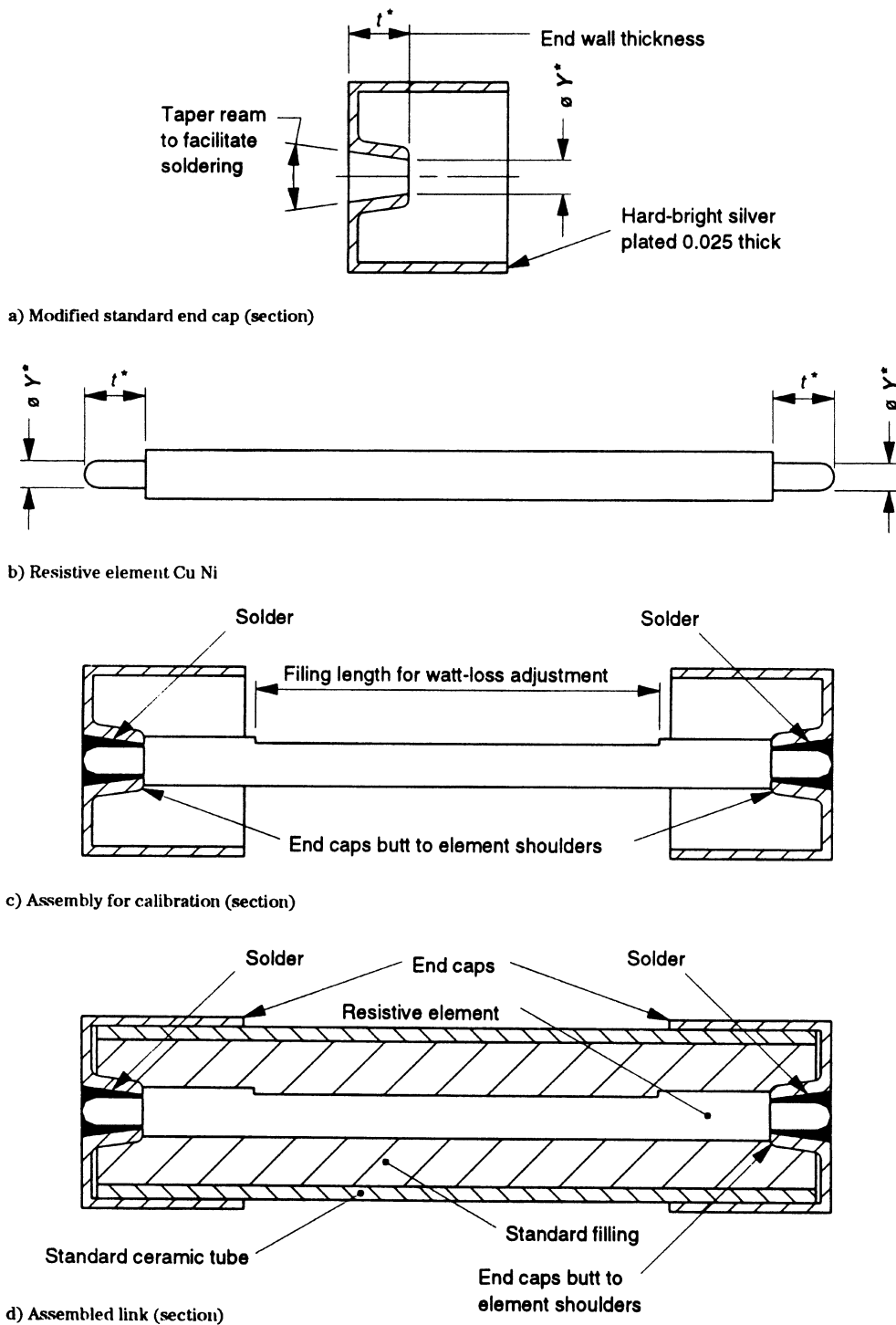

* See annex A.

Figure 28 — Calibrated link (see A.1)

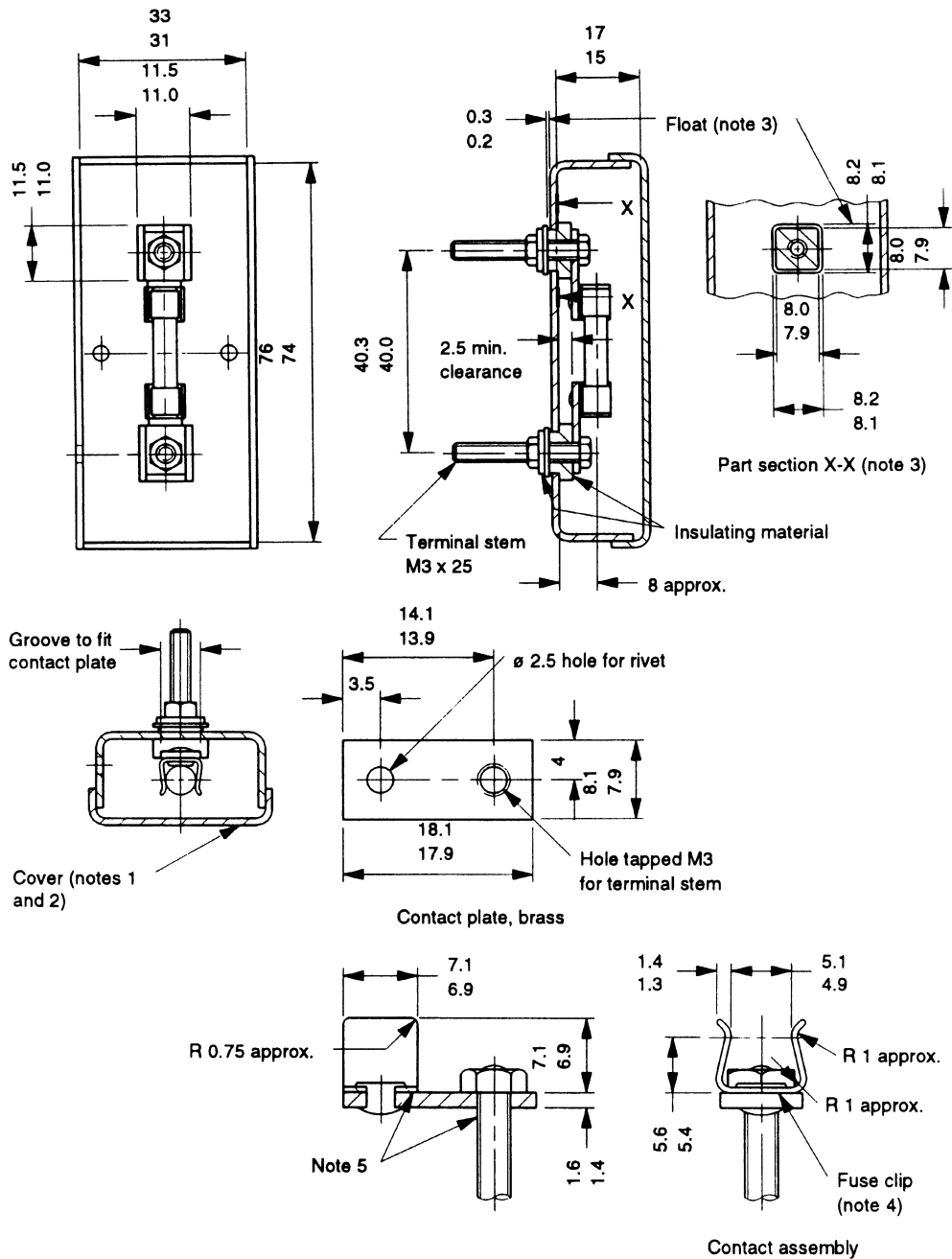

All dimensions are in millimetres.

NOTE 1. Box and cover made from 1.25 mm brass sheet, clean natural finish.

NOTE 2. Cover should be a push fit on box and should not be rigidly attached.

NOTE 3. The end float and clearance between the insulation and the box is to allow the contacts to be self-aligning.

NOTE 4. Fuse clip. Made from beryllium copper 0.45 mm thick and heat treated (170 HV minimum). Base of clip to be flat; finish, silver plated.

NOTE 5. Joints between clip, contact plate and terminal stem to be soldered.

Figure 29 — Calibration of calibrated link (see A.2)

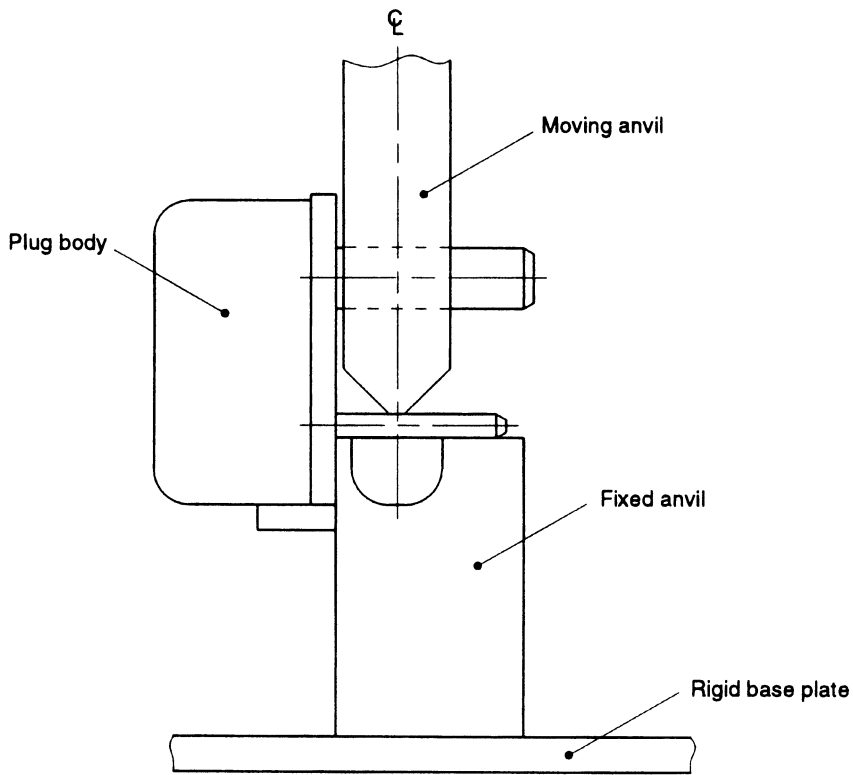

a) A plug-pin under test

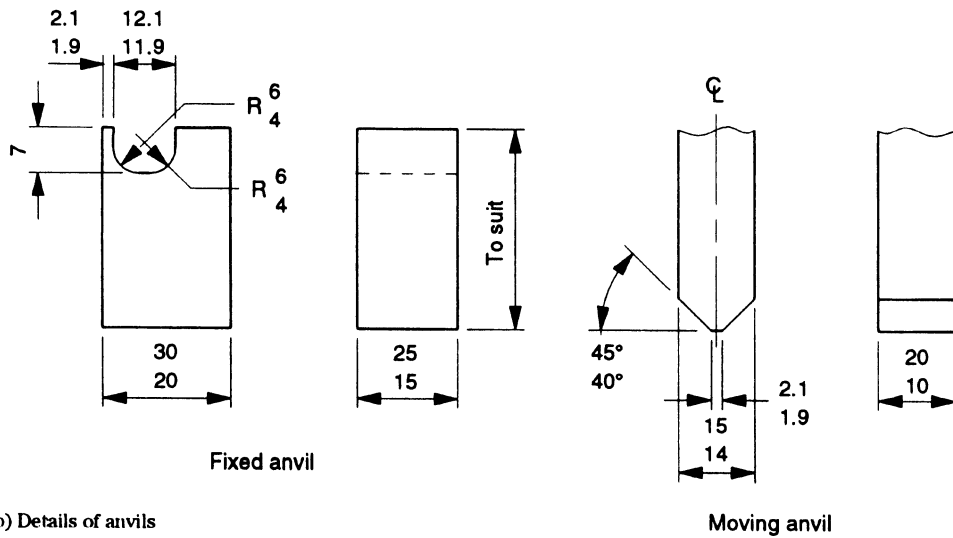

b) Details of anvils

All linear dimensions are in millimetres.

NOTE. The body of the plug should be supported so that the face of the plug is held in contact with the face of the fixed anvil.
The moving anvil should be aligned in the centre of the gap in the fixed anvil.

Figure 32 — Apparatus for tests on plug pins (see Clause 12)

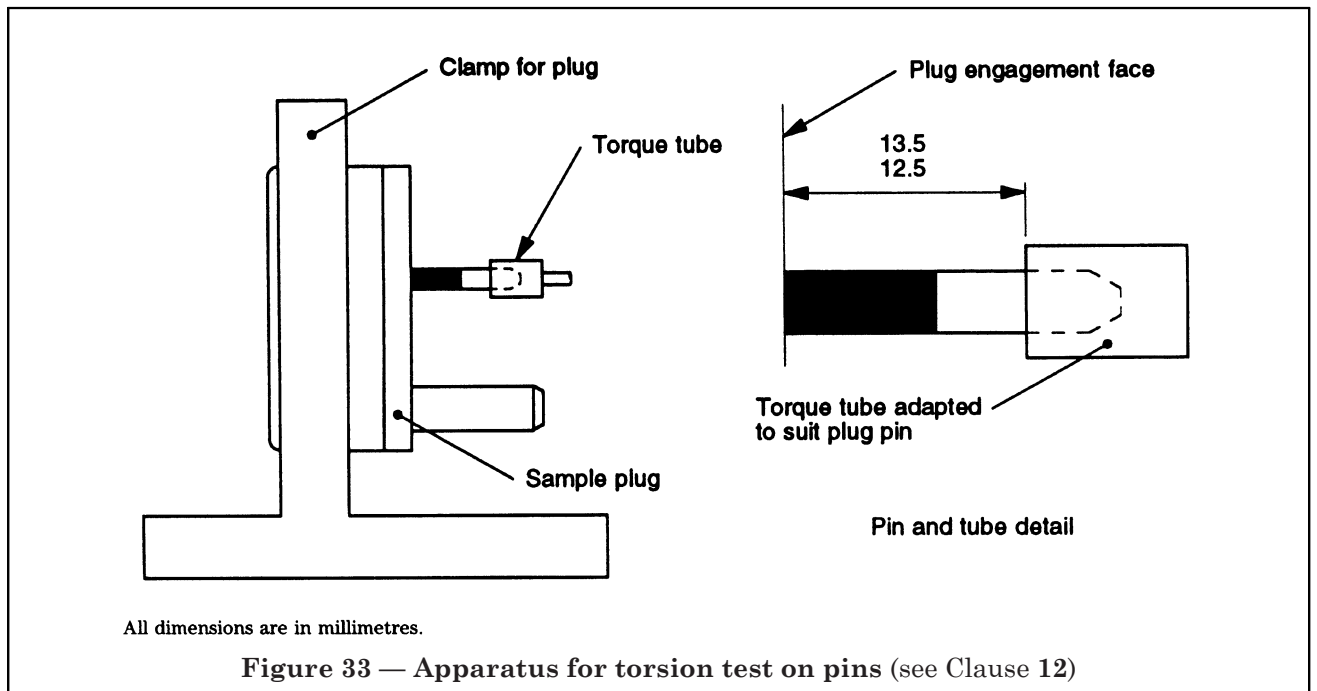

List of references

BSI publications

BS 219:1977, *Specification for soft solders.*

BS 1362:1973, *Specification for general purpose fuse links for domestic and similar purposes (primarily for use in plugs).*

BS 1363-2:1995, *13 A plugs, socket-outlets, adaptors and connection units — Part 2: Specification for 13 A switched and unswitched socket-outlets.*

BS 1363-3:1995, *13 A plugs, socket-outlets, adaptors and connection units — Part 3: Specification for adaptors.*

BS 1363-4:1995, *13 A plugs, socket-outlets, adaptors and connection units — Part 4: Specification for 13 A fused connection units: switched and unswitched.*

BS 2572:1990, *Specification for phenolic laminated sheet and epoxy cotton fabric laminated sheet.*

BS 2870:1980, *Specification for rolled copper and copper alloys: sheet, strip and foil.*

BS 4662:1970, *Specification for boxes for the enclosure of electrical accessories.*

BS 4800:1989, *Schedule of paint colours for building purposes.*

BS 5216:1991, *Specification for patented cold drawn steel wire for mechanical springs.*

BS 5901:1980, *Method of test for determining the comparative and the proof tracking indices of solid insulating materials under moist conditions.*

BS 6004:2000, *Electric cables — PVC insulated, non-armoured cables for voltages up to and including 450/750 V, for electric power, lighting and internal wiring.*

BS 6217:1981, *Guide to graphical symbols for use on electrical equipment.*

BS 6500:2000, *Electric cables — Flexible cords rated up to 300/500 V, for use with appliances and equipment intended for domestic, office and similar environments.*

^{A4} BS EN 50525, *Electric cables — Low voltage energy cables of rated voltages up to and including 450/750 V (U₀/U).* ^{A4}

^{A3} BS EN 60112:2003, *Method for the determination of the proof and the comparative tracking indices of solid insulating materials.*

BS EN 60664-1, *Insulation coordination for equipment within low-voltage systems — Part 1: Principles, requirements and tests.* ^{A3}

^{A4} BS EN 60695-2-11:2001, *Fire hazard testing — Part 2-11 :Glowing/hot-wire based test methods — Glow-wire flammability test method for end-products.*

BS EN 60695-10-2:2003, *Fire hazard testing — Part 10-2: Abnormal heat — Ball pressure test.* ^{A4}

BS EN 61032:1998, *Protection of persons and equipment by enclosures — Probes for verification.*

^{A3} BS EN 61140, *Protection against electric shock — Common aspects for installation and equipment.* ^{A3}

^{A4} BS EN 61180-1:1995, *Guide to high-voltage test techniques for low-voltage equipment — Part 1: Definitions, test and procedure requirements.* ^{A4}

BSI — British Standards Institution

BSI is the independent national body responsible for preparing British Standards. It presents the UK view on standards in Europe and at the international level. It is incorporated by Royal Charter.

Revisions

British Standards are updated by amendment or revision. Users of British Standards should make sure that they possess the latest amendments or editions.

It is the constant aim of BSI to improve the quality of our products and services. We would be grateful if anyone finding an inaccuracy or ambiguity while using this British Standard would inform the Secretary of the technical committee responsible, the identity of which can be found on the inside front cover.
Tel: +44 (0)20 8996 9000. Fax: +44 (0)20 8996 7400.

BSI offers members an individual updating service called PLUS which ensures that subscribers automatically receive the latest editions of standards.

Buying standards

Orders for all BSI, international and foreign standards publications should be addressed to Customer Services. Tel: +44 (0)20 8996 9001.
Fax: +44 (0)20 8996 7001. Email: orders@bsi-global.com. Standards are also available from the BSI website at <http://www.bsi-global.com>.

In response to orders for international standards, it is BSI policy to supply the BSI implementation of those that have been published as British Standards, unless otherwise requested.

Information on standards

BSI provides a wide range of information on national, European and international standards through its Library and its Technical Help to Exporters Service. Various BSI electronic information services are also available which give details on all its products and services. Contact the Information Centre.
Tel: +44 (0)20 8996 7111. Fax: +44 (0)20 8996 7048. Email: info@bsi-global.com.

Subscribing members of BSI are kept up to date with standards developments and receive substantial discounts on the purchase price of standards. For details of these and other benefits contact Membership Administration.
Tel: +44 (0)20 8996 7002. Fax: +44 (0)20 8996 7001.
Email: membership@bsi-global.com.

Information regarding online access to British Standards via British Standards Online can be found at <http://www.bsi-global.com/bsonline>.

Further information about BSI is available on the BSI website at <http://www.bsi-global.com>.

Copyright

Copyright subsists in all BSI publications. BSI also holds the copyright, in the UK, of the publications of the international standardization bodies. Except as permitted under the Copyright, Designs and Patents Act 1988 no extract may be reproduced, stored in a retrieval system or transmitted in any form or by any means – electronic, photocopying, recording or otherwise – without prior written permission from BSI.

This does not preclude the free use, in the course of implementing the standard, of necessary details such as symbols, and size, type or grade designations. If these details are to be used for any other purpose than implementation then the prior written permission of BSI must be obtained.

Details and advice can be obtained from the Copyright & Licensing Manager.
Tel: +44 (0)20 8996 7070. Fax: +44 (0)20 8996 7553.
Email: copyright@bsi-global.com.