



# Standard Test Method for Making, Accelerated Curing, and Testing Concrete Compression Test Specimens<sup>1</sup>

This standard is issued under the fixed designation C 684; the number immediately following the designation indicates the year of original adoption or, in the case of revision, the year of last revision. A number in parentheses indicates the year of last reapproval. A superscript epsilon ( $\epsilon$ ) indicates an editorial change since the last revision or reapproval.

## 1. Scope

1.1 This test method covers four procedures for making, curing, and testing specimens of concrete stored under conditions intended to accelerate the development of strength. The four procedures are: Procedure A—Warm Water Method, Procedure B—Boiling Water Method, Procedure C—Autogenous Curing Method, and Procedure D—High Temperature and Pressure Method.

1.2 The values stated in SI units are to be regarded as standard. The values given in parentheses are provided for information purposes only.

1.3 *This standard does not purport to address all of the safety concerns, if any, associated with its use. It is the responsibility of the user of this standard to establish appropriate safety and health practices and determine the applicability of regulatory limitations prior to use.* See Section 9 and Note 9 and Note 14 for specific warnings and precautions.

## 2. Referenced Documents

### 2.1 ASTM Standards:<sup>2</sup>

- C 31/C 31M Practice for Making and Curing Concrete Test Specimens in the Field
- C 39 Test Method for Compressive Strength of Cylindrical Concrete Specimens
- C 172 Practice for Sampling Freshly Mixed Concrete
- C 177 Test Method for Steady-State Heat Flux Measurements and Thermal Transmission Properties by Means of the Guarded-Hot-Plate Apparatus
- C 192/C 192M Practice for Making and Curing Concrete Test Specimens in the Laboratory

- C 470 Specification for Molds for Forming Concrete Test Cylinders Vertically
- C 617 Practice for Capping Cylindrical Concrete Specimens
- C 1231 Practice for Use of Unbonded Caps in Determination of Compressive Strength of Hardened Concrete Cylinders
- D 3665 Practice for Random Sampling of Construction Materials
- E 105 Practice for Probability Sampling of Materials
- E 122 Practice for Calculating Sample Size to Estimate, With a Specified Tolerable Error, the Average for Characteristics of a Lot or Process
- E 141 Practice for Acceptance of Evidence Based on the Results of Probability Sampling

## 3. Terminology

3.1 There are no terms in this standard that require new or other than dictionary definitions.

## 4. Summary of Test Method

4.1 Concrete specimens are exposed to accelerated curing conditions that permit the specimens to develop a significant portion of their ultimate strength within a time period ranging from 5 to 49 h, depending upon the procedure that is used. Procedures A and B utilize storage of specimens in heated water at elevated curing temperatures without moisture loss. The primary function of the moderately heated water used in Procedure A is to serve as insulation to conserve the heat generated by hydration. The temperature level employed in Procedure B provides thermal acceleration. Procedure C involves storage of specimens in insulated curing containers in which the elevated curing temperature is obtained from heat of hydration of the cement. The sealed containers also prevent moisture loss. Procedure D involves simultaneous application of elevated temperature and pressure to the concrete using special containers. Sampling and testing procedures are the same as for normally cured specimens (see Practice C 172 and Test Method C 39, respectively).

<sup>1</sup> This test method is under the jurisdiction of ASTM Committee C09 on Concrete and Concrete Aggregates and is the direct responsibility of Subcommittee C09.61 on Testing for Strength.

Current edition approved Nov. 10, 1999. Published February 2000. Originally approved in 1971. Last previous edition approved in 1999 as C 684 – 99.

<sup>2</sup> For referenced ASTM standards, visit the ASTM website, [www.astm.org](http://www.astm.org), or contact ASTM Customer Service at [service@astm.org](mailto:service@astm.org). For *Annual Book of ASTM Standards* volume information, refer to the standard's Document Summary page on the ASTM website.

4.2 Important characteristics of these procedures are shown in Table 1.

## 5. Significance and Use

5.1 The accelerated curing procedures provide, at the earliest practical time, an indication of the potential strength of a specific concrete mixture. These procedures also provide information on the variability of the production process for use in quality control.

5.2 The accelerated early strength obtained from any of the procedures in this test method can be used to evaluate concrete strengths in the same way conventional 28-day strengths have been used in the past, with suitable changes in the expected strength values. Since the practice of using strength values obtained from standard-cured cylinders at 28 days is long established and widespread, the results of accelerated strength tests are often used to estimate the later-age strength under standard curing. Such estimates should be limited to concretes using the same materials and mixture proportions as those used for establishing the correlation. Appendix X2 provides a procedure to estimate the 90 % confidence interval of the average later-age strength based on accelerated strength test results.

5.3 Correlation between accelerated strength and strength achieved at some later age by using conventional curing methods depends upon the materials comprising the concrete, the mixture proportions, and the specific accelerated test procedure.

5.4 The user shall choose which procedure to use on the basis of experience and local conditions. These procedures, in general, will be practical when a field laboratory is available to house the curing containers and the testing equipment to measure compressive strength within the specified time limits.

## 6. Interferences

6.1 When wet sieving of the concrete sample is required prior to molding the test specimens due to maximum aggregate size limitations (such as Procedure D, which is limited to 25 mm maximum), consider the effect of wet sieving on the air content and strength of the test specimens.

## 7. Apparatus

7.1 Equipment and small tools for fabricating specimens, measuring slump, and determining air content shall conform to Practice C 31/C 31M.

### 7.2 Molds:

7.2.1 Cylinder molds for test specimens used in Procedures A, B, and C shall conform to Specification C 470. Paper molds are excluded. When specimens are to be tested without capping, use only reusable molds with machined end plates that can be securely connected to both top and bottom of the mold. The end plates shall produce specimens with bearing surfaces that are plane within 0.05 mm (0.002 in.) and whose ends do not depart from perpendicularity to the axis of the cylinder by more than 0.5° (approximately equivalent to 10 mm/m (1/8 in. in 12 in.)). When assembled, the mold assembly is sufficiently tight to permit the filled mold to be turned from the vertical filling position to a horizontal curing position without loss of mortar or damage to the test specimen.

7.2.2 Cylinder molds for Procedure D shall conform to the following:

7.2.2.1 Made of stainless steel,

7.2.2.2 Equipped with removable top and bottom metal plugs and O-ring seals,

7.2.2.3 Equipped with a heating element capable of raising the concrete temperature within the mold to  $150 \pm 3^\circ\text{C}$  ( $300 \pm 5^\circ\text{F}$ ) within  $30 \pm 5$  min, and are capable of maintaining this temperature throughout the time required by the test procedure,

7.2.2.4 Equipped with devices to measure the temperature within each mold to ascertain that the temperature of the concrete satisfies the temperature requirements stated herein, and

7.2.2.5 Equipped with a companion loading component capable of maintaining a pressure of  $10.3 \text{ MPa} \pm 0.2 \text{ MPa}$  ( $1500 \pm 25$  psi) on the concrete during the curing period.

### 7.3 Curing Apparatus:

#### 7.3.1 Accelerated Curing Tank for Procedures A and B:

7.3.1.1 The tank is of any configuration suitable for the number of cylinders to be tested. Arrange the cylinders in any configuration that provides a clearance of at least 50 mm (2 in.) between the side of each cylinder and the side of the tank, and at least 100 mm (4 in.) between adjacent cylinders. Maintain the water level at least 100 mm (4 in.) above the tops of the cylinders.

NOTE 1—Provision for an overflow pipe is a convenience in controlling the maximum depth of water. A number of different tanks have been used successfully. Guidelines are given in Appendix X1.

**TABLE 1 Characteristics of Accelerated Curing Procedures**

Procedure	Molds	Source of Strength Acceleration	Accelerated Curing Temperature °C (°F)	Age Accelerated Curing Begins	Duration of Accelerated Curing	Age at Testing
A. Warm Water	reusable or single-use	heat of hydration	35 (95)	immediately after casting	$23.5 \text{ h} \pm 30 \text{ min}$	$24 \text{ h} \pm 15 \text{ min}$
B. Boiling Water	reusable or single-use	boiling water	boiling	$23 \text{ h} \pm 30 \text{ min}$ after casting	$3.5 \text{ h} \pm 5 \text{ min}$	$28.5 \text{ h} \pm 15 \text{ min}$
C. Autogenous	single-use	heat of hydration	initial concrete temperature augmented by heat of hydration	immediately after casting	$48 \text{ h} \pm 15 \text{ min}$	$49 \text{ h} \pm 15 \text{ min}$
D. High-Temperature and Pressure	reusable	external heat and pressure	150 (300)	immediately after casting	$5 \text{ h} \pm 5 \text{ min}$	$5.25 \text{ h} \pm 5 \text{ min}^A$

<sup>A</sup>Add 30 min if capping with sulfur compound is used.

7.3.1.2 Equip the tank with environmental control element(s) capable of: (1) providing the specified water temperature, (2) maintaining the water temperature within  $\pm 3^{\circ}\text{C}$  ( $\pm 5^{\circ}\text{F}$ ) of the specified value at any point in the water, and (3) limiting the temperature drop, after immersion of specimens, to less than  $3^{\circ}\text{C}$  ( $5^{\circ}\text{F}$ ) and returning to the specified water temperature within 15 min. Thermometers or other temperature recording devices are required, independent of the thermostat, to check the temperature of the water.

NOTE 2—Depending upon the design features of the tank, insulation or mechanical agitation, or both, might be necessary to meet the specified temperature requirements. Electrical immersion heaters controlled by a thermostat are one suitable form of heating elements. For a particular procedure, the size of the heating element required will depend upon the size of the tank and the number of specimens to be cured at one time.

7.3.1.3 The plate supporting the specimens is perforated to permit circulation of the water.

7.3.1.4 A close fitting lid to reduce evaporation is required for Procedure B but is optional for Procedure A.

#### 7.3.2 *Curing Container for Procedure C:*

7.3.2.1 The container consists of thermal insulation meeting heat retention requirements of 12.2.1 and closely surrounding the concrete specimen.

7.3.2.2 The container is capable of being opened to permit insertion and withdrawal of the specimen and has an outer casing and inner liner to protect the insulation from mechanical damage.

7.3.2.3 The container has a maximum-minimum recording thermometer which is not insulated from the concrete specimen (see Note 10).

7.3.2.4 The container has a lid or other means to provide secure closure during the specified curing period. The lid includes a heat seal that satisfies the requirements of 12.2.2.

7.3.2.5 The container is capable of holding either one or two specimens.

NOTE 3—Examples of suitable containers are included in Appendix X1. Any configuration is acceptable provided it meets the performance requirements of 12.2.

#### 7.3.3 *Curing Apparatus for Procedure D:*

7.3.3.1 The curing apparatus consists of a loading system to apply the specified pressure to the concrete specimens and special molds to maintain the concrete specimens at the specified temperature during the curing period. The curing apparatus can be of any configuration suitable for the number of cylindrical specimens to be tested. Appendix X1 describes a successful apparatus designed for curing three specimens.

#### 7.4 *Capping Apparatus:*

7.4.1 If capping of the test specimens is required, use the apparatus specified in Practice C 617 or Practice C 1231.

## 8. Materials

8.1 Capping compound or pad caps for use when the ends of the test specimens are unsuitable for testing without capping.

## 9. Hazards

9.1 Observe OSHA requirements and standard laboratory and field safety precautions when sampling, molding, curing, and testing concrete.

9.2 Observe the additional safety measures indicated when using Procedure B to prevent scalding or other burns resulting from the use of boiling water as a curing medium.

9.3 Observe the additional safety measures indicated when using Procedure D to prevent injury due to the high temperature and pressure used for curing.

## 10. Sampling

10.1 Determine the number of tests required from the concrete lot(s) or process. Use a random or systematic plan that provides the number of tests needed to characterize the strength of the concrete used in the construction.

10.2 If the lot(s) or process is stratified into sublots, locate the samples using a stratified random procedure. If circumstances dictate a non-stratified approach, use a random procedure.

NOTE 4—A stratified random sampling procedure can be implemented by dividing each lot of concrete into a number of equal-sized sublots, and randomly selecting a sample from each subplot. The number of sublots equals the number of samples that were scheduled to be taken from the lot. For example, if the job requirements called for each  $500\text{ m}^3$  of concrete to be treated as a lot and that five samples be obtained from each lot to determine compressive strength, divide the lot into five equal-sized sublots of  $100\text{ m}^3$  each. Randomly obtain one sample from each subplot. Test results from the five samples obtained in this manner provide unbiased estimates of the compressive strength of the  $500\text{ m}^3$  lot. This is the most practical approach to ensure that the samples obtained include the entire range of concrete in the production process. If unequal size sublots occur due to the construction process, weighting of the test results may be appropriate to maintain the fairness and defensibility of the sampling procedure.

NOTE 5—Practice D 3665 contains a table of random numbers, including instructions for use. Practices E 105, E 122, and E 141 contain additional information concerning sampling practices.

10.3 Sample the freshly mixed concrete in accordance with Practice C 172. Record in the job records the location at which the sampled batch is used in the structure.

## 11. Preparation of Apparatus

### 11.1 *Methods A and B:*

11.1.1 Activate the environmental control elements at least 1 h prior to the start of a scheduled test to allow the temperature of the water and equipment to stabilize.

### 11.2 *Method C:*

11.2.1 Conduct the proving tests specified in Section 12 prior to scheduling tests.

### 11.3 *Method D:*

11.3.1 Clean and check the molds and end plugs before starting a test. Standardize the loading system in accordance with Section 12 prior to scheduling tests.

## 12. Standardization

12.1 For all methods, verify the calibration of temperature measurement, control, and recording components on a frequent periodic basis. Calibrate such components in accordance with the manufacturer's recommendations or standard laboratory practice.

### 12.2 *Method C Requirements:*

12.2.1 *Heat Retention*—Place a watertight cylindrical container with internal dimensions of 300 mm (12 in.) in height by

150 mm (6 in.) in diameter into the autogenous curing container. Fill the container to within 6 mm (¼ in.) of the brim with water at a temperature of 82°C (180°F). Insert a thermocouple into the water and measure the initial temperature of the water with a suitable readout device. Then seal the water container with a cap or plastic bag and close the autogenous container. When the autogenous curing container is stored in still air at 21 ± 1°C (70 ± 2°F), the water temperature requirements are as follows:

Elapsed time, h	°C	°F
12	67 ± 3	152 ± 5
24	58 ± 3	136 ± 6
48	45 ± 4	114 ± 7
72	38 ± 4	100 ± 8

12.2.2 *Tightness Test for Gasket Heat Seal*—When the autogenous curing container is immersed in water to a depth of 150 mm (6 in.) above the joint between the separable parts, no air shall escape through the heat seal within a period of 5 min.

12.2.3 *Stability of the Container*—The container, or any part thereof, shall not display embrittlement, fracturing, or distortion when maintained in an ambient temperature of –30°C (–20°F) for 72 h, nor softening or distortion when maintained at an ambient temperature of 60°C (140°F) for 72 h. The gasket type heat seal immediately shall recover fully its original thickness after 50 % compression under the temperature conditions specified above.

### 12.3 Method D:

12.3.1 Verify the calibration of the loading component on a periodic basis. If the loading component is also used for compression testing of the specimens, follow the requirements of Test Method C 39.

## 13. Conditioning

13.1 The relatively short curing periods used for concrete test specimens in this test method require that particular attention be directed to conditioning of equipment and test specimens. Adhere carefully to the specified temperature and time requirements in each method.

## 14. Procedure

### 14.1 Procedure A—Warm Water Method:

#### 14.1.1 Preparation of Test Specimens:

14.1.1.1 Mold the test specimens in accordance with the requirements of Practice C 31/C 31M or Practice C 192/C 192M, whichever is applicable.

#### 14.1.2 Curing:

14.1.2.1 If necessary, cover the top of the specimens with a rigid plate to prevent loss of mortar to the water bath.

14.1.2.2 Immediately after molding, place the specimens into the curing tank (Note 6). Maintain the water at the time of immersion and throughout the curing period at 35 ± 3°C (95 ± 5°F).

NOTE 6—If the specimens are cast in molds meeting the requirements of 7.2.1.1 they may be stored horizontally, otherwise they are stored in the curing tank with the long axis vertical.

14.1.2.3 Record the temperature of the curing water either continuously or periodically throughout the curing period.

14.1.2.4 After curing for 23.5 h ± 30 min, remove the specimens from the tank and remove the molds.

### 14.1.3 Capping and Testing:

14.1.3.1 Cap the ends of specimens that are not plane within 0.05 mm (0.002 in.) or that depart from perpendicularity to the central axis by more than 0.5° (approximately equivalent to 10 mm/m (¼ in. in 12 in.)) as specified in Practice C 617 or Practice C 1231 (see Note 7).

NOTE 7—Grinding of cylinders to achieve the flatness requirements is permitted provided the specimens are tested within the specified time limits.

14.1.3.2 For bonded caps, use capping material that develops, at an age of 30 min when tested in accordance with the provisions of Practice C 617, a strength equal to or greater than the strength of the specimens to be tested.

14.1.3.3 If bonded caps are used, do not test specimens sooner than 30 min after capping.

14.1.3.4 Test the specimens for strength in accordance with Test Method C 39 at the age of 24 h ± 15 min.

### 14.2 Procedure B—Boiling Water Method:

#### 14.2.1 Preparation of Test Specimens:

14.2.1.1 Prepare specimens in accordance with 14.1.1.

#### 14.2.2 Initial Curing:

14.2.2.1 Cover the specimens to prevent loss of moisture and store so that they will not be disturbed. Maintain the storage area temperature at 21 ± 6°C (70 ± 10°F). Adhere to the requirements of Practice C 31/C 31M in the protection and storage of test specimens.

NOTE 8—Strict attention to the protection and storage of the specimens during this initial period is necessary for meaningful results because of the short total curing period.

#### 14.2.3 Accelerated Curing:

14.2.3.1 At 23 h ± 15 min after molding, place the covered molds in the water tank (Note 9). Maintain the temperature of the water at the time of immersion and throughout the curing period at boiling (Note 10).

NOTE 9—**Precaution:** In addition to other precautions, wear appropriate protection for the eyes, face, hands, and arms to prevent injury from the sudden release of steam upon opening the container or immersion of the cylinder into the boiling water. Lifting tongs are suggested to slowly lower the molds into the boiling water without splashing.

NOTE 10—In confined places, the temperature of the water may be kept just below the boiling point to avoid excessive evaporation. The temperature at which water boils varies because of differences in elevation above sea level. Differences in strengths caused by the differences in temperatures are not believed to be significant, but comparison of results among areas so affected should be supported by appropriate correlations and interpreted with the knowledge of the temperature variations.

14.2.3.2 Record the temperature of the curing water either continuously or periodically throughout the curing period.

14.2.3.3 After curing for 3.5 h ± 5 min, remove the specimens from the boiling water, remove the molds, and allow the specimens to cool at room temperature for at least 1 h prior to capping.

### 14.2.4 Capping and Testing:

14.2.4.1 Cap and test the specimens in accordance with 14.1.3, except that the age at time of test is 28.5 ± 15 min.

### 14.3 Procedure C—Autogenous Method:

### 14.3.1 Preparation of Test Specimens:

#### 14.3.1.1 Prepare specimens in accordance with 14.1.1.

NOTE 11—Metal, reusable molds with end plates and clamps may be impracticable for Procedure C.

### 14.3.2 Curing:

14.3.2.1 Immediately after molding, cover the mold with a metal plate or a tightly fitted cap and place in a heavy-duty plastic bag from which as much of the entrapped air as possible is expelled prior to tying the neck. (Alternatively, a moisture-tight plastic cap may be used.) Use a plastic bag of sufficient strength to resist punctures and serve as a lifting grip for placing and removing the specimen from the autogenous container.

14.3.2.2 Reset the maximum-minimum thermometer, and, after the specimen is inserted into the container, secure the container lid.

14.3.2.3 Clearly record the time of molding to the nearest 15 min and the temperature of the freshly molded concrete on the outside of the curing container.

14.3.2.4 Store the curing container for at least 12 h in a location not subject to disturbance or direct sunlight, and preferably at a temperature of  $21 \pm 6^\circ\text{C}$  ( $70 \pm 10^\circ\text{F}$ ).

14.3.2.5 At the age of  $48 \text{ h} \pm 15 \text{ min}$  after the specimen was molded, remove the specimen from the container and remove the mold. Allow to stand at room temperature for 30 min.

14.3.2.6 Record the maximum and minimum temperatures in the container indicated on the thermometer.

NOTE 12—Comparison of the maximum and minimum temperatures with the recorded temperature of the fresh concrete will provide an indication of abnormal or interrupted curing which may cause high or low strength results.

### 14.3.3 Capping and Testing:

14.3.3.1 Cap and test the specimens in accordance with 14.1.3, except that the age at the time of test is  $49 \text{ h} \pm 15 \text{ min}$ .

NOTE 13—Capping and testing may be performed at an age different from that specified in 14.3.3. Agencies using the procedure have, for convenience, established relationships between test results at 24, 72, and 96 h with those obtained by standard moist curing. However, at 24 h, the relationship is less satisfactory than those obtained by accelerated autogenous curing for 48, 72, or 96 h. Where the curing period is other than that specified in 14.3.3, the age at testing should be the curing period plus 1 h. The tolerance of  $\pm 15 \text{ min}$  should still apply.

## 14.4 Procedure D—High Temperature and Pressure Method:

### 14.4.1 Preparation of Test Specimens:

14.4.1.1 For the curing apparatus described in Appendix X1, the molds are  $75 \times 150 \text{ mm}$  ( $3 \times 6 \text{ in.}$ ) cylinders. Seal the molds with their bottom plugs before filling with concrete.

14.4.1.2 Procedure D is limited to concrete containing 25-mm (1-in.) maximum size aggregate. Wet sieve concrete containing aggregate larger than 25 mm (1 in.) in accordance with Practice C 172.

14.4.1.3 Place the concrete in the molds in two equal layers and rod each layer 10 times. Screed the top of the concrete with a special tool (see Fig. X1.3) to achieve the level of concrete required to receive the top metal plug that transmits the designated pressure of  $10.3 \pm 0.2 \text{ MPa}$  ( $1500 \pm 25 \text{ psi}$ ) to the concrete in the mold.

### 14.4.2 Curing:

14.4.2.1 Immediately after molding, cover each mold with a metal plug to seal the concrete inside the mold during the curing process.

14.4.2.2 Stack the molds vertically and place them in the loading apparatus described in 7.3.3.1. Apply and maintain a pressure of  $10.3 \pm 0.2 \text{ MPa}$  ( $1500 \pm 25 \text{ psi}$ ) on the concrete within the molds.

14.4.2.3 Activate the heating element specified in 7.2.2 to elevate the temperature of the specimen to  $150 \pm 3^\circ\text{C}$  ( $300 \pm 5^\circ\text{F}$ ) within  $30 \pm 5 \text{ minutes}$ . The curing period begins when the heating element is activated.

14.4.2.4 The curing period lasts  $5 \text{ h} \pm 5 \text{ min}$ . During the first 3 h, maintain the specimen temperature at  $150 \pm 3^\circ\text{C}$  ( $300 \pm 5^\circ\text{F}$ ). After 3 h, turn off the heating element and maintain the pressure at  $10.3 \pm 0.2 \text{ MPa}$  ( $1500 \pm 25 \text{ psi}$ ) for the remainder of the curing period.

14.4.2.5 At the end of the curing period, release the pressure, remove the molds from the loading apparatus, and extrude the specimens from the molds.

NOTE 14—**Precaution:** The use of high temperature and pressure imposes the need for safety measures to prevent scalding or eye burns resulting from sudden escape of steam upon removal of plugs from the molds. In addition to other precautions, wear eye, face, and hand protection, while removing the specimens from the molds. It is suggested that the plugs be removed by prying in a direction away from the operator.

NOTE 15—Polypropylene plastic liners can be used inside the molds to facilitate extrusion of the cured concrete from the molds.

### 14.4.3 Capping and Testing:

14.4.3.1 Normally the specimens do not need to be capped for testing since the metal plugs produce suitably plane bearing surfaces. If the end surfaces do not meet the requirements of 14.1.3.1, cap the specimens in accordance with 14.1.3.

14.4.3.2 Test the specimens for strength in accordance with Test Method C 39 within 15 min after removing the molds. When capping is required, test the specimens 30 min after capping.

NOTE 16—The loading apparatus used for the curing period can also be designed to function as a suitable compression testing machine (see Appendix X1).

## 15. Interpretation of Results<sup>3</sup>

15.1 Strength requirements in existing specifications and codes are not based upon accelerated curing; therefore, apply results from this test method in the prediction of specification compliance of strengths at later ages with great caution. As stated in Section 17, the variability of the test method is the same or less than that from traditional methods. Thus, results can be used in rapid assessment of variability for process control and signalling the need for indicated adjustments. On the other hand, the magnitude of the strength values obtained is influenced by the specific combination of materials so that the use of the results from either conventional tests at any arbitrary age or those from this test method must be supported by

<sup>3</sup> Carino, N. J., "Prediction of Potential Concrete Strength at Later Ages," ASTM STP 169C, *Significance of Tests and Properties of Concrete and Concrete Making Materials*, 1994, pp. 140–152.

experience or correlations developed by the specific agency for the existing local conditions and materials.

15.2 When this test method is used as a means to estimate standard-cured strength at a specified age, statistical methods shall be used to account for the various uncertainties associated with making such estimates. Appendix X2 provides an acceptable procedure for this purpose. Prior to using this test method to estimate standard-cured strength, all interested parties shall agree on the statistical procedures to be used and how the results are to be interpreted. If this test method is used for acceptance testing, the acceptance criterion shall be stated in the project documents.

NOTE 17—A recommended criterion for acceptance of concrete on the basis of accelerated strength testing is that the lower limit of the 90 % confidence interval of the estimated average strength of the sample tested should conform to the acceptance criteria for standard moist-cured cylinders.

## 16. Report

16.1 Report the following for each test specimen:

16.1.1 Identification number,

16.1.2 Diameter (and length, if not standard) in millimetres (or inches),

16.1.3 Cross-sectional area, in square millimetres (or square inches),

16.1.4 Maximum load, in newtons (or pounds-force),

16.1.5 Compressive strength calculated to the nearest 0.1 MPa (10 psi),

16.1.6 Type of fracture, if other than the usual cone,

16.1.7 Defects in either the specimen or the caps (if used),

16.1.8 Age of the specimens,

16.1.9 Accelerated curing procedure used,

16.1.10 Maximum and minimum temperature to the nearest °C (°F) if Procedure C was used.

16.1.11 If applicable, method of transportation used for shipping the specimens to the laboratory, and

16.1.12 Ambient temperature of the specimen during initial curing in Procedure B or of the container during storage for Procedure C.

## 17. Precision and Bias

### 17.1 Precision:

17.1.1 The data used to prepare the following precision statements was obtained using measurements in the inch-pound system.

17.1.2 The single-laboratory coefficient of variation for specimens cast from the same batch has been determined as 3.6 % for 150 × 300-mm (6 × 12-in.) cylinders (as used in Procedures A, B, and C) and as 6.7 % for 75 × 150-mm (3 × 6-in.) cylinders (as used in Procedure D) (Note 18). Therefore, for 150 × 300-mm (6 × 12-in.) cylinders tested according to Procedures A, B, and C, individual results of two properly conducted strength tests, by the same laboratory on specimens made from the same batch, should not differ more than 10.1 % of their average. For 75 × 150-mm (3 × 6-in.) cylinders tested according to Procedure D, the maximum acceptable difference between three individual test results is 22.1 %.

17.1.3 The single-laboratory, coefficient of variation for test results among batches cast on different days has been determined as 8.7 % for 150 × 300-mm (6 × 12-in.) cylinders as used in Procedures A, B, and C, and as 20 % for 75 × 150-mm (3 × 6-in.) cylinders as used in Procedure D (Note 19). A test result is the average strength of two specimens for Procedures A, B, and C and the average of three specimens for Procedure D. Therefore, results of two properly conducted strength tests from different batches of the same materials cast on different days should differ by no more than 24.4 % of their average for 150 × 300-mm (6 × 12-in.) cylinders and 56.0 % for 75 × 150-mm (3 × 6-in.) cylinders (Note 19).

NOTE 18—These numbers represent the (1s %) limit as described in Practice C 670.

NOTE 19—These numbers represent, respectively, the (1s %) and (d2s %) limits as described in Practice C 670.

## 18. Keywords

18.1 accelerated curing; compressive strength; testing

## APPENDIXES

### (Nonmandatory Information)

#### X1. CURING APPARATUS

##### X1.1 Accelerated Curing Tank (Procedures A and B)

X1.1.1 Curing tanks similar to that shown in Fig. X1.1 have been used successfully.

X1.1.2 Properly designed tanks will ensure an almost uniform temperature throughout the tank without the need for a mechanical stirrer. Locate the immersion heaters centrally in the plan and as near to the bottom of the tank as possible. The water above the heater will then be kept in circulation by convection currents.

X1.1.3 For a tank containing two or three specimens, two coupled elements (1500 and 5000 W) have been found suitable for use with Procedure B. While the smaller elements will maintain the specified curing temperature, the larger element is required as a booster to reestablish boiling within the specified time after the specimens have been immersed. Where the tank is to be used solely for Procedure A, the above heaters are also suitable, but a single 3000-W element has also been found suitable. With the 3000-W element, the tank may be of larger

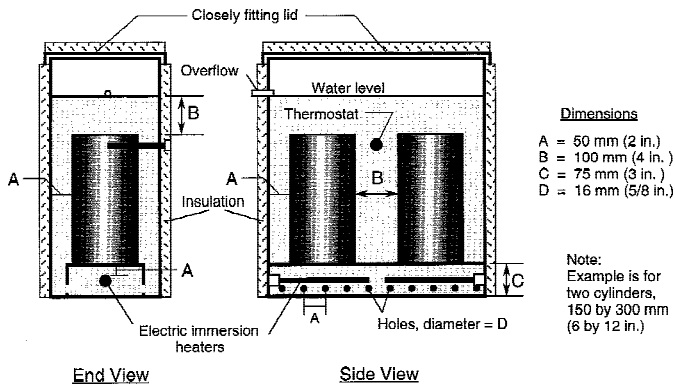

FIG. X1.1 Suggested Design for Accelerated Curing Tank (Procedure A or B)

dimensions to hold more than two or three specimens when used for Procedure A.

X1.1.4 The overflow pipe, closely fitting lid, and exterior insulation are not essential for curing tanks used only for Procedure A.

**X1.2 Autogenous Curing Container (Procedure C)**

X1.2.1 Satisfactory containers are shown in Fig. X1.2.

X1.2.2 The space for the maximum-minimum thermometer and the means of opening the container, securing when closed, and lifting are not shown.

X1.2.3 A heat seal is required at the joint face between the separable parts of the container. This may be a labyrinth or a gasket type seal provided the requirements of 12.2.1, 12.2.2,

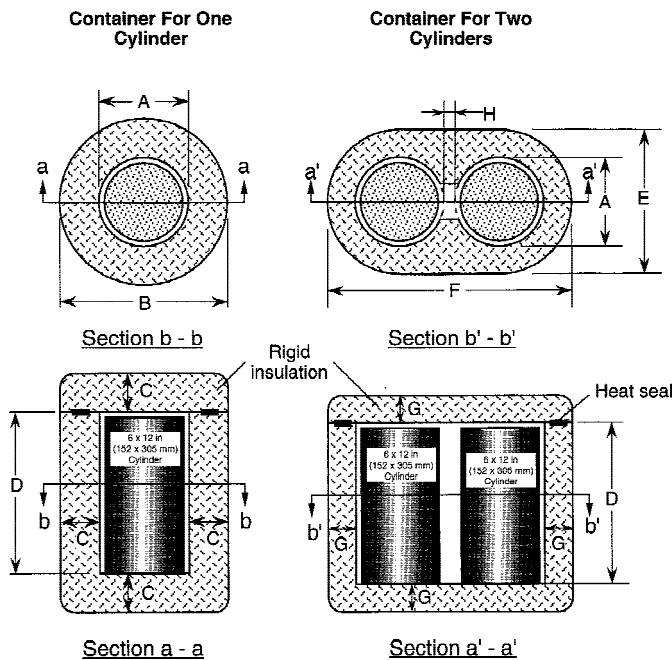

- Dimensions**
- A = 162 to 165 mm (6-3/8 to 6-1/2 in.)
  - B = 314 to 317 mm (12-3/8 to 12-1/2 in.)
  - C = 76 mm (3 in.)
  - D = 311 mm (12-1/4 in.)
  - E = 290 to 293 mm (11-3/8 to 11-1/2 in.)
  - F = 464 to 483 mm (18-1/4 to 19 in.)
  - G = 64 mm (2-1/2 in.)
  - H = 13 to 25 mm (1/2 to 1 in.)

FIG. X1.2 Autogenous Curing Container for One or Two Cylinders (Procedure C)

and 12.2.3 are met. A suitable gasket is flexible polyurethane foam (32 kg/m<sup>3</sup> or 2 lb/ft<sup>3</sup>) maintained when closed at 50 % compression.

X1.2.4 Foamed-in-place closed-cell polyurethane having a density of between 32 and 48 kg/m<sup>3</sup> (2 and 3 lb/ft<sup>3</sup>) and thermal conductivity equal to or less than 0.02 W/m-K (0.15 Btu-in./h-ft<sup>3</sup>°F) in accordance with Test Method C 177 has been found to be a suitable insulating material at the thicknesses specified to meet the heat retention requirements of 12.2.1.

X1.2.5 The maximum-minimum thermometer should cover a range from - 10 to 65°C (20 to 150°F) in 1° increments.

**X1.3 High Temperature and Pressure Equipment (Procedure D)**

X1.3.1 A satisfactory apparatus for Procedure D is shown in Fig. X1.3.

X1.3.2 Properly designed molds will ensure an almost uniform temperature throughout the concrete. The heater wires are normally spaced closer together near the edges of the mold and further apart in its central region.

X1.3.3 For a 75 × 150-mm (3 × 6-in.) cylindrical mold, a heating element of 100 W will raise and maintain the specified temperature during the curing period. Regular fiberglass insulation with a rating of R20 was found to be sufficient for the suggested heating element and required curing cycle. Each mold has its own electrical circuitry so that if one fails to function, two molds will remain to cure two specimens in a satisfactory manner. The electrical system shall have current indicators, a timer, and a buzzer in order to make the curing procedure automatic and simple to monitor.

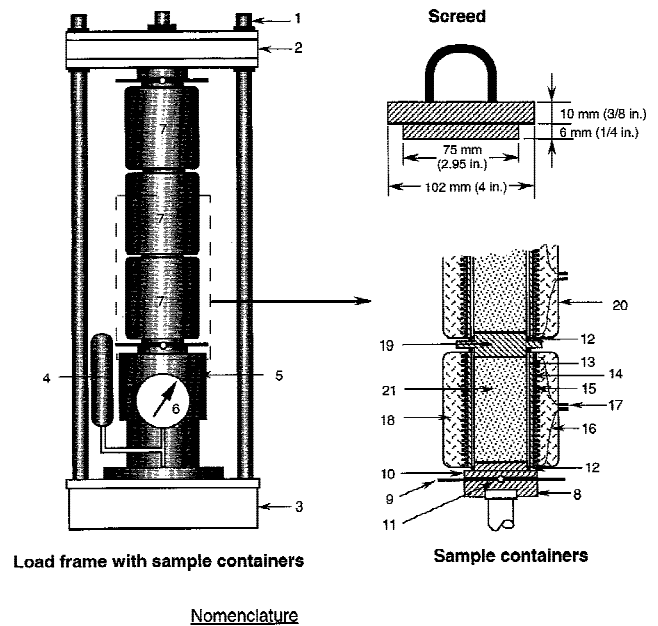

- Nomenclature**
- 1. Connecting rods
  - 2. Head member
  - 3. Base
  - 4. Accumulator
  - 5. Hydraulic jack
  - 6. Pressure gage
  - 7. Sample container
  - 8. Head bearing disc
  - 9. Heat shield
  - 10. Cap and piston
  - 11. Ball bearing
  - 12. O-ring
  - 13. Plastic liner
  - 14. Cylinder mold
  - 15. Wire insulation
  - 16. Heating wire
  - 17. Electrical Connector
  - 18. Glass wool insulation
  - 19. Piston
  - 20. Container covering
  - 21. Concrete specimen

FIG. X1.3 Schematic of High-Temperature and Pressure Curing Apparatus (Procedure D)

X1.3.4 The hydraulic jack and accumulator shall be equipped with a pressure gage to indicate the pressure being applied to the concrete in the molds. The accumulator shall be calibrated so that it will maintain the required pressure of  $10.3 \pm 0.2$  MPa ( $1500 \pm 25$  psi).

X1.3.5 If it is desired to use the apparatus to test the specimens, then the apparatus shall be designed to function as a compression testing machine satisfying the requirements of Test Method C 39.

## X2. ESTIMATION OF LATER-AGE STRENGTH

### X2.1 Regression Equation

X2.1.1 To estimate the potential later-age strength from a measured early-age accelerated strength, the laboratory must first conduct enough tests to establish the relationship between the two types of strength. This will usually require preparing a series of six to ten mixtures with water-cement ratios varying over the maximum credible range that may be encountered during construction. These mixtures must include similar materials to those that will be used in construction. Ordinary least-squares regression analysis is used to obtain the equation of the line representing the relationship between standard-cured and accelerated strengths **(1,2)**.<sup>4</sup> This relationship is applicable only to the specific materials and accelerated test procedure that were used. To account for the uncertainty in the resulting regression line, confidence bands for the line are established **(1)**. Then, for a new accelerated strength, the confidence interval for the average later-age strength can be estimated. The following procedure and illustrative example are based on earlier work by Wills **(3)** and Carino **(4)**.

X2.1.2 In this discussion, it will be assumed that the relationship between the standard-cured strength ( $Y$ ) and the accelerated strength ( $X$ ) can be represented by a straight line with the following equation:

$$Y = a + bX \quad (X2.1)$$

However, for some concrete mixtures, the relationship between these two types of strength may not be linear. For these situations, the measured strength values should be transformed by taking their natural logarithms. The natural logarithms of the strengths would be used to obtain the average  $X$  and  $Y$  values to be used in subsequent calculations. The last step would be to perform exponentiation to convert the computed confidence intervals to strength values.

X2.1.3 Assume that  $n$  pairs of  $(X_i, Y_i)$  values are obtained from laboratory testing, where  $X_i$  and  $Y_i$  are the average strengths of accelerated and standard-cured specimens. The intercept,  $a$ , and slope,  $b$ , of the straight line are determined using the procedure of ordinary least squares **(1)**:

$$b = \frac{S_{xy}}{S_{xx}} \quad (X2.2)$$

$$a = \bar{Y} - b\bar{X} \quad (X2.3)$$

where:

$$S_{xy} = \sum (X_i - \bar{X})(Y_i - \bar{Y}) \quad (X2.4)$$

$$S_{xx} = \sum (X_i - \bar{X})^2 \quad (X2.5)$$

$$\bar{X} = \sum \frac{X_i}{n} \quad (X2.6)$$

$$\bar{Y} = \sum \frac{Y_i}{n} \quad (X2.7)$$

The residual standard deviation,  $s_e$ , of the best-fit line is given by the following:

$$s_e = \sqrt{\frac{1}{n-2} \left( S_{yy} - \frac{S_{xy}^2}{S_{xx}} \right)} \quad (X2.8)$$

where:

$$S_{yy} = \sum (Y_i - \bar{Y})^2 \quad (X2.9)$$

X2.1.4 To illustrate the procedure, consider the 12 pairs of accelerated and standard-cured, 28-day strengths given in the first two columns of Table X2.1. Each number is the average strength of two cylinders. Using the preceding equations, the following values are to be obtained:

$$\bar{X} = 16.30 \text{ MPa (2366 psi)}$$

$$\bar{Y} = 38.90 \text{ MPa (5646 psi)}$$

$$S_{xx} = 105.32 \text{ (MPa)}^2$$

$$S_{yy} = 164.14 \text{ (MPa)}^2$$

$$S_{xy} = 125.22 \text{ (MPa)}^2$$

The slope of the line is  $b = 125.22/105.32 = 1.19$ , and the intercept is  $a = 38.90 - 1.19 \times 16.30 = 19.50$  MPa (2830 psi).

**TABLE X2.1 Values Used in Sample Problem to Illustrate Estimation of Confidence Interval for 28-day Strength**

NOTE 1—For an approximate conversion to psi multiply the values by 145.

Accelerated Strength, $X_i$ , MPa	28-day Strength, $Y_i$ , MPa	Estimated Strength, $Y_i$ , MPa	$W_i$ , MPa	Lower Confidence Limit, MPa	Upper Confidence Limit, MPa
12.06	33.71	33.85	1.50	32.35	35.35
12.15	34.33	33.96	1.48	32.48	35.44
12.96	35.23	34.92	1.30	33.62	36.22
13.85	35.05	35.98	1.12	34.86	37.10
15.19	37.74	37.58	0.92	36.66	38.50
16.09	37.21	38.65	0.86	37.79	39.51
17.08	40.71	39.82	0.89	38.93	40.71
18.15	40.97	41.10	1.02	40.08	42.12
18.24	41.96	41.20	1.03	40.17	42.23
18.42	41.60	41.42	1.06	40.36	42.48
20.12	45.73	43.44	1.41	42.03	44.85
21.28	42.50	44.82	1.69	43.13	46.51
Confidence Interval for Estimated Strength at Accelerated Strength of 17.00 MPa					
17.00		39.73	0.89	38.84	40.62
16.40		39.01	0.86	38.15	
17.60		40.44	0.94		41.38

<sup>4</sup> The boldface numbers in parentheses refer to the list of references at the end of this standard.



Therefore, the equation of the relationship between accelerated strength ( $X$ ) and standard-cured strength ( $Y$ ) is as follows:

$$Y = 19.50 + 1.19 X \text{ (MPa)} \quad (X2.10)$$

Fig. X2.1 shows the 12 data pairs and the calculated best-fit line. The residual standard deviation of the line,  $s_e$ , is as follows:

$$s_e = \sqrt{\frac{1}{10} \left( 164.14 - \frac{125.22^2}{105.32} \right)} = 1.23 \text{ MPa (178 psi)} \quad (X2.11)$$

### X2.2 Confidence Band for Regression Line

X2.2.1 Because of the uncertainties in the estimates of the slope and the intercept of the line, there will be uncertainty when the line is used to estimate the average standard-cured strength from a measured accelerated strength. This uncertainty may be expressed by constructing the 90 % confidence band for the line (1,5). This band is obtained by calculating  $Y_i$  for selected values of  $X_i$  using the equation of the line and plotting  $Y_i \pm W_i$  versus  $X_i$ . The term  $W_i$  is the half-width of the confidence band at  $X_i$  and is given by the following equation:

$$W_i = s_e \sqrt{2F} \sqrt{\frac{1}{n} + \frac{(X_i - \bar{X})^2}{S_{xx}}} \quad (X2.12)$$

where:

$s_e$  = residual standard deviation for the best-fit line (Eq X2.8),

$F$  = value from  $F$ -distribution for 2 and  $n-2$  degrees of freedom and significance level 0.10,

$n$  = number of data points used to establish regression line,

$X_i$  = selected value of accelerated strength, and

$\bar{X}$  = grand average value of accelerated strength for all data used to establish the regression line.

The third column in Table X2.1 lists the estimated average 28-day strengths for the accelerated strengths in Column 1. The value of  $W_i$  at each value  $X_i$  is listed in the fourth column of Table X2.1. Finally, Columns 5 and 6 list the values of the

lower and upper 90 % confidence limits, which are shown in Fig. X2.1. Note that the width of the confidence band is narrowest when  $X_i$  equals  $\bar{X}$ , because the second term under the square root sign in Eq X2.12 equals zero.

### X2.3 Estimate of Later-Age Strength

X2.3.1 Suppose that the average accelerated strength of two cylinders made in the field from similar concrete is 17.0 MPa (2470 psi). From the regression equation, the estimated average 28-day, standard-cured strength is 39.7 MPa (5760 psi). If the accelerated strength was known without error, the 90 % confidence interval for the average 28-day strength would be 38.8 to 40.6 MPa (5630 to 5890 psi) (see the bottom of Table X2.1). However, the accelerated strength has an uncertainty that is described by the within-batch standard deviation, which can be estimated from the differences between the accelerated strengths of pairs of cylinders (6). Assume that the compressive strengths measured on field-prepared cylinders by the specific accelerated test method has a within-batch coefficient of variation of 3.0 %. Therefore, the standard deviation,  $s$ , at an average strength of 17.0 MPa is 0.51 MPa (74 psi). The 90 % confidence interval for the average accelerated strength of the two cylinders is as follows:

$$17.0 \pm z_{0.05} \frac{s}{\sqrt{2}} = 17.0 \pm 1.645 \times 0.51 \times 0.707 = 17.0 \pm 0.6 \text{ MPa (2470} \pm 90 \text{ psi)} \quad (X2.13)$$

where  $z_{0.05}$  is the value from the standard normal distribution corresponding to 5 % of the area under the curve. Thus the 90 % confidence interval<sup>5</sup> for the average accelerated strength is 16.4 to 17.6 MPa (2380 to 2550 psi). Projecting the limits of this interval to the lower and upper confidence bands of the regression line results in 38.2 to 41.4 MPa (5540 to 6010 psi) for the approximate 90 % confidence interval for the average standard-cured, 28-day strength. Each different measurement of accelerated strength produces a new confidence interval for the average 28-day strength. The use of a personal computer is recommended for implementing the preceding calculations for routine use.

X2.3.2 As the regression equation starts to be used on the project, companion cylinders should be prepared along with cylinders for accelerated testing. The companion cylinders would be subjected to standard curing and tested for compressive strength at the designated age. The measured standard-cured strengths should be compared with the confidence intervals for the estimated strengths based on the companion accelerated strengths. If the measured strengths consistently fall outside the estimated confidence intervals, the reliability of the regression line and its associated statistics is questionable.

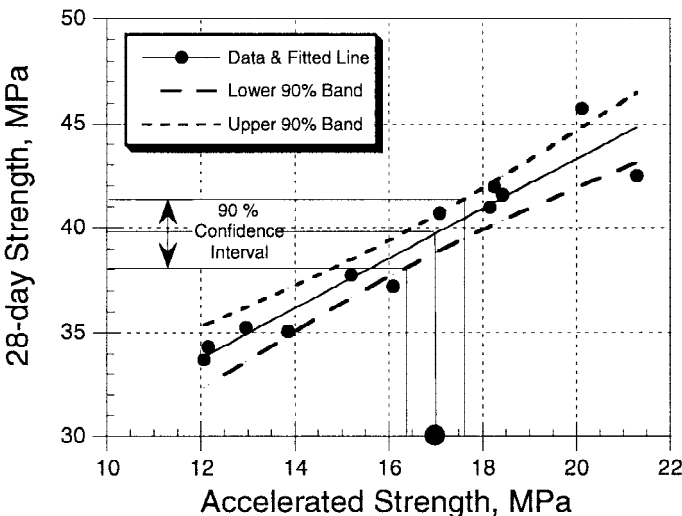

FIG. X2.1 Confidence Bands for the Estimated 28-day Strength Based on Measured Accelerated Strength; 90 % Confidence Interval for an Accelerated Strength of 17.0 MPa are Shown

<sup>5</sup> The 90 % confidence interval is often interpreted to mean that there is a 90 % probability that the true mean falls within the interval. However, the correct interpretation is as follows: If 100 repeated samples are taken from the same population and the 90 % confidence intervals for the mean are computed in each case, 90 of the intervals would include the true mean. The 90 % confidence band for the regression line has a similar interpretation: If 100 groups of data are taken from the same population and the 90 % confidence bands are computed for the regression equations, 90 % of those bands would include the true regression line for the population. See Mendenhall and Sincich (7) for further explanations on the proper interpretation of confidence intervals.

The new companion results should be added to the data set from the laboratory correlation testing to calculate a new regression line and its corresponding statistics. This new line should be used for subsequent estimates of potential later-age strength. The making of companion sets of accelerated and standard-cured cylinders should be continued until the measured strengths consistently fall within the corresponding calculated confidence intervals. Once the reliability of the procedure has been demonstrated, companion cylinders should be made at random intervals to reconfirm that the procedure continues to be reliable.

## X2.4 Summary

X2.4.1 A procedure has been presented to estimate the average standard-cured, 28-day strength from accelerated

strength test results. The procedure accounts for the uncertainty in the regression line and in the measured accelerated strength. It is insufficient to simply use the regression equation to convert the accelerated strength to an equivalent 28-day strength. Additional information on the procedure presented in the example may be found in the references by Moore and Taylor (8) and in Miller (5). Finally, it is emphasized that a particular regression equation is valid only for a specific accelerated test procedure and combination of materials. Therefore, each laboratory must conduct enough tests with a given set of materials and a certain procedure to establish the regression line and its confidence bands before estimations of standard-cured strengths are possible.

## REFERENCES

- (1) Natrella, M. G., *Experimental Statistics, NBS Handbook 91*, National Bureau of Standards, Washington, DC, August 1963.
- (2) Draper, N.R., and Smith, H., *Applied Regression Analysis*, 2nd ed., John Wiley & Sons, New York, NY, 1981.
- (3) Wills, M.H., "Early Assessment of Concrete Quality by Accelerating Compressive Strength Development with Heat (Results of ASTM Cooperative Test Program)," *Journal of Testing and Evaluation*, Vol 3, No. 4, July 1975, pp. 251-262.
- (4) Carino, N.J., "Prediction of Potential Strength at Later Ages," Chapter 15, *ASTM STP 169C, Significance of Tests and Properties of Concrete and Concrete Making Materials*, Paul Klieger and Joseph F. Lamond, eds., 1994, pp. 140-152.
- (5) Miller, R.G., *Simultaneous Statistical Inference*, 2nd ed., Springer-Verlag, New York, 1981.
- (6) "Recommended Practice for Evaluation of Strength Test Results of Concrete," *ACI 214-77(97)*, Reported by ACI Committee 214, American Concrete Institute, Farmington Hills, MI.
- (7) Mendenhall, W., and Sincich, T., *Statistics for Engineering and the Sciences*, 3rd ed., Dellen Publishing Co., San Francisco, CA, 1992.
- (8) Moore, J.K., and Taylor, M.A., "Statistical Properties of Techniques for Predicting Concrete Strength and Examples of Their Use," *ACI SP-56, Accelerated Strength Testing*, V.M. Malhotra, ed., American Concrete Institute, 1978, pp. 259-283.

*ASTM International takes no position respecting the validity of any patent rights asserted in connection with any item mentioned in this standard. Users of this standard are expressly advised that determination of the validity of any such patent rights, and the risk of infringement of such rights, are entirely their own responsibility.*

*This standard is subject to revision at any time by the responsible technical committee and must be reviewed every five years and if not revised, either reapproved or withdrawn. Your comments are invited either for revision of this standard or for additional standards and should be addressed to ASTM International Headquarters. Your comments will receive careful consideration at a meeting of the responsible technical committee, which you may attend. If you feel that your comments have not received a fair hearing you should make your views known to the ASTM Committee on Standards, at the address shown below.*

*This standard is copyrighted by ASTM International, 100 Barr Harbor Drive, PO Box C700, West Conshohocken, PA 19428-2959, United States. Individual reprints (single or multiple copies) of this standard may be obtained by contacting ASTM at the above address or at 610-832-9585 (phone), 610-832-9555 (fax), or service@astm.org (e-mail); or through the ASTM website (www.astm.org).*