

CONFIRMED  
NOVEMBER 1990

Specification for

**Screwed and socketed  
steel tubes and tubulars  
and for plain end steel  
tubes suitable for  
welding or for screwing  
to BS 21 pipe threads**

UDC 621.643.2—034.14

# Committees responsible for this British Standard

The preparation of this British Standard was entrusted by the Piping Systems Standards Committee (PSE/-) to Technical Committee PSE/8, upon which the following bodies were represented:

Adhesive Tape Manufacturers' Association  
 British Compressed Air Society  
 British Gas Corporation  
 British Malleable Tube Fittings Association  
 British Steel industry  
 British Valve Manufacturers' Association Ltd.  
 Engineering Equipment and Materials Users' Association  
 Food Manufacturers' Federation Incorporated  
 Institution of Civil Engineers  
 Institution of Gas Engineers  
 Institution of Public Health Engineers  
 Institution of Water Engineers and Scientists  
 Mechanical Handling Engineers Association  
 Society of Motor Manufacturers and Traders Limited  
 Stainless Steel Fabricators' Association of Great Britain  
 Water Authorities Association  
 Water Companies Association  
 Water Research Centre  
 Wrought Fitting Makers' Association

This British Standard, having been prepared under the direction of the Piping Systems Components Standards Committee, was published under the authority of the Board of BSI and comes into effect on 31 October 1985

© BSI 12-1998

First published (as BS 789)  
 February 1938  
 First revision (as War emergency BS 789A) October 1940  
 Second revision (as BS 1387) July 1947  
 Third revision November 1957  
 Fourth revision March 1967  
 Fifth revision October 1985

The following BSI references relate to the work on this standard:  
 Committee reference PSE/8  
 Draft for comment 84/72359 DC

## Amendments issued since publication

Amd. No.	Date of issue	Comments
5830	May 1989	Indicated by a sideline in the margin

ISBN 0 580 14503 4

# Contents

	Page
Committees responsible	Inside back cover
Foreword	iii
<hr/>	
Section 1. General	
1.1 Scope	1
1.2 Definitions	1
1.3 Designations	1
1.4 Information to be supplied by the purchaser in the enquiry or order	1
<hr/>	
Section 2. Tubes and sockets	
2.1 Manufacture	2
2.2 Mechanical properties	2
2.3 Appearance and soundness	2
2.4 Joints	2
2.5 Dimensions and tolerances	2
<hr/>	
Section 3. Testing	
3.1 Visual inspection	4
3.2 Tensile test	4
3.3 Bend test (whole tube)	4
3.4 Flattening test	4
3.5 Leak tightness test	4
3.6 Bore test (hot-dip zinc coated tubes only)	4
3.7 Manufacturer's certificate	4
<hr/>	
Section 4. Protection	
4.1 General	5
4.2 Varnish	5
4.3 Hot-dip zinc coating	5
4.4 Threads	5
<hr/>	
Section 5. Tubulars	
5.1 General	6
5.2 Sockets	6
5.3 Pieces	6
5.4 Nipples	6
5.5 Longscrews	6
5.6 Bends and springs	6
5.7 Return bends	6
5.8 Protection	6
<hr/>	
Section 6. Marking	
6.1 Tubes and tubulars	7
<hr/>	
Appendix A Information to be supplied by the purchaser in the enquiry or order	15
Appendix B Eddy current testing of tubes as an alternative to the hydraulic leak tightness test	15
Appendix C Method for testing the zinc coating on hot-dip zinc coated tubes and tubulars (copper sulphate test)	16
<hr/>	
Figure 1 — Socket	8
Figure 2 — Piece	9
Figure 3 — Nipples	10
Figure 4 — Single long screw	11
Figure 5 — Double long screw	11

---

	Page
Figure 6 — Bends and springs	13
Figure 7 — Return bend	14
<hr/>	
Table 1 — Chemical composition and mechanical properties at room temperature	2
Table 2 — Rod diameters	4
Table 3 — Dimensions of steel tubes: light	7
Table 4 — Dimensions of steel tubes: medium	7
Table 5 — Dimensions of steel tubes: heavy	8
Table 6 — Sockets	8
Table 7 — Pieces	9
Table 8 — Running nipples, close taper nipples and barrel nipples	10
Table 9 — Longscrews	12
Table 10 — Bends and springs	14
Table 11 — Return bends	14
Table 12 — Drill diameters	16
Table 13 — Length immersed and volume of test solution	17
<hr/>	
Publications referred to	Inside back cover

---

# Foreword

This revision of this British Standard has been prepared under the direction of the Piping Systems Components Standards Committee and supersedes BS 1387:1967 which is withdrawn.

The range of components covered in this revision is the same as and technically equivalent with those of ISO 50 and ISO 65 published by the International Organization for Standardization (ISO). It should be noted that some of the tolerances given in this standard are more stringent than those given in ISO 65.

The revision has been prepared to bring the standard into line with current practice and to clarify the requirements in a more definitive manner. Leak tightness requirements have been updated with the inclusion of eddy current testing as an alternative to hydraulic leak tightness testing and metric units are used throughout this standard. Thread designations, which were previously expressed in inch units, but which are now dimensionless, are retained for information in this standard because these designations are still generally used throughout industry.

Tubes specified in this standard are intended for general purposes. This standard does not indicate the services for which the tubes are appropriate. Where the use of tubes is controlled by bye-laws or regulations reference should be made to the appropriate code of practice or application standard.

This standard does allow options to the standard product, the preferred option, where applicable, being indicated in the appropriate clause. Particular requirements should be indicated by the purchaser, as stated in appendix A, otherwise the manufacturer will supply the product in accordance with the preferred options.

A British Standard does not purport to include all the necessary provisions of a contract. Users of British Standards are responsible for their correct application.

**Compliance with a British Standard does not of itself confer immunity from legal obligations.**

## Summary of pages

This document comprises a front cover, an inside front cover, pages i to iv, pages 1 to 18, an inside back cover and a back cover.

This standard has been updated (see copyright date) and may have had amendments incorporated. This will be indicated in the amendment table on the inside front cover.



# Section 1. General

## 1.1 Scope

This British Standard specifies requirements for screwed and socketed steel tubes and tubulars and for plain end steel tubes suitable for welding or for screwing to BS 21 pipe threads. This standard is applicable to tubes of nominal size DN 8 to DN 150 in three series of thickness, designated light, medium and heavy.

NOTE The titles of the publications referred to in this standard are listed on the inside back cover.

## 1.2 Definitions

For the purposes of this British Standard the following definitions apply.

### 1.2.1

#### **nominal size (DN)**

a numerical designation of size which is common to all components in a piping system other than components designated by outside diameters or thread size. It is a convenient round number for reference purposes and is only loosely related to manufacturing dimensions

NOTE 1 Nominal size is designated by the letters DN followed by a number.

NOTE 2 This definition is identical to ISO 6708.

### 1.2.2

#### **tube**

a long hollow, open-ended object of circular cross section

NOTE The term tube is synonymous with the term pipe.

### 1.2.3

#### **socket**

the screwed coupling utilized in joining the tubes together

NOTE The term socket is synonymous with the term coupler.

### 1.2.4

#### **tubulars**

pieces, nipples, long screws, bends, springs and return bends

NOTE See section five and Table 7 to Table 11.

### 1.2.5

#### **length of screwed and socketed tube**

##### 1.2.5.1

#### ***exact length***

the length of tube exclusive of the socket

##### 1.2.5.2

#### ***length, other than the exact length***

the overall length when one socket has been fitted

NOTE See also 2.5.2 d).

### 1.2.6

#### **standard length**

the nominal length of a pipe component which by virtue of custom and practice has become the normal length to which the component is supplied

## 1.3 Designations

### 1.3.1 Tubes

Tubes shall be designated by the number of this British Standard, the nominal size (DN) and thickness series as given in Table 3, Table 4 and Table 5 together with the type of end finish (plain or screwed ends), e.g. BS 1387 DN 20 medium series, screwed and socketed tube.

### 1.3.2 Tubulars

Tubulars shall be designated by the number of this British Standard, the nominal size (DN), thickness series, type of tubular and, where appropriate, their length. In addition, bends and springs shall be designated by their type reference (see Figure 6 and Figure 7), e.g. BS 1387 DN 20 medium series, bend type 1.

### 1.3.3 Sockets and backnuts

Sockets and backnuts shall be designated by the number of this British Standard and the respective nominal size (DN) of the tube for which they are intended, e.g. BS 1387 DN 20 backnut.

## 1.4 Information to be supplied by the purchaser in the enquiry or order

This standard allows a number of options. Therefore, to assist the purchaser, a check list of the options together with the other information to be supplied in the enquiry or order is given in appendix A.

## Section 2. Tubes and sockets

### 2.1 Manufacture

#### 2.1.1 Manufacture of the steel

The steel shall be produced by the electric or one of the basic oxygen processes and shall be fully killed, semi-killed or rimmed.

#### 2.1.2 Manufacture of the product

Tubes shall be manufactured by a welded process. Sockets shall be manufactured by a seamless or welded process.

#### 2.1.3 Chemical composition

The chemical composition of the steel shall comply with Table 1.

NOTE 1 Chemical analysis of the finished product is not required.

NOTE 2 This steel is regarded as being weldable. However, care should be taken and welding should be carried out in accordance with the appropriate British Standards.

#### 2.1.4 Heat treatment

Tubes shall be supplied in the annealed or normalized condition, the as-welded condition, the as-welded condition with the weld zone heat treated, or after a hot finishing process.

### 2.2 Mechanical properties

The mechanical properties at room temperature shall be as given in Table 1.

### 2.3 Appearance and soundness

2.3.1 Small imperfections which do not intrude on the minimum thickness or which can be dressed out such that the thickness after dressing remains within the tolerance limit shall be deemed not to affect compliance with this standard. Surface imperfections shall not be peened.

2.3.2 Screw threads shall comply with the requirements of BS 21 except as provided for in 2.4.

2.3.3 The ends shall be cut cleanly and nominally square with the axis of the tube and be free from excessive burrs.

2.3.4 The tubes shall be straight to within 1 in 500 as measured at the centre of the length.

2.3.5 The tubes shall not include welds used for joining lengths of strip.

### 2.4 Joints<sup>1)</sup>

All screwed tubes and sockets shall be threaded in accordance with BS 21 except as provided below and except that on light tubes the length of useful thread shall be reduced to 80 % of that shown in column 12 of Table 2 of BS 21:1985.

Where light tubes approach the lower limits of outside diameter some "black" threads (perfect at the root and imperfect at the crest) are to be expected beyond the gauge plane, but such "black" threads shall be deemed not to affect the compliance of the tubes with this standard.

Tubes shall be supplied screwed with taper threads and fitted with one screwed socket having a parallel thread unless it is specifically requested by the purchaser in his enquiry or order (see appendix A) that the tubes shall be supplied without sockets or supplied with a socket having a taper thread.

### 2.5 Dimensions and tolerances

#### 2.5.1 Dimensions

The dimensions of tubes shall be as given in Table 3, Table 4 and Table 5.

Dimensions of sockets shall be as given in Table 6.

NOTE A socket is shown in Figure 1.

Table 1 — Chemical composition and mechanical properties at room temperature

Chemical composition (ladle)				Mechanical properties at room temperature		
C	Mn	P	S	Tensile strength, $R_m$	Yield strength, $R_e$ (min.)	Elongation on gauge length $L_0 = 5.65 \sqrt{S_0 A}$ (min.)
max.	max.	max.	max.			
%	%	%	%	N/mm <sup>2</sup>	N/mm <sup>2</sup>	%
0.20	1.20	0.045	0.045	320 to 460	195	20

<sup>1)</sup> Care is necessary when hand screwing "light" tubes.



### 2.5.2 Tolerances

The tolerances on the outside diameter, thickness, mass and length shall be as follows.

a) *Outside diameter.*

Light tubes	as given in Table 3
Medium and heavy tubes	as given in Table 4 and Table 5 respectively

b) *Thickness.*

Light tubes	- 8 %
Medium and heavy tubes	-10 %

c) *Mass.* The mean consignment mass for quantities of 150 m and over of one size shall not deviate by more than  $\pm 4\%$  from the mass of the consignment calculated from the masses given in Table 3, Table 4 and Table 5 as appropriate. No single tube shall deviate by more than  $\begin{matrix} +10 \\ -8 \end{matrix}\%$  from the mass given in Table 3, Table 4 and Table 5 as appropriate.

d) Length (see note).

1) *Random lengths.* When random lengths are ordered, tubes shall be supplied in one of the following ways:

- in random lengths from 4 m to 7 m;
- (for orders of over 150 m of any one size of tube) in random lengths from 4 m to 7 m but including short random lengths from 1.8 m to 4 m provided that the number of such lengths does not exceed 7.5 % of the total number of lengths for DN 65 to DN 100 inclusive, and 5 % for all other sizes.
- as for (b) but including tubes with two lengths joined together to make a random length, provided that the number of such jointed lengths does not exceed 7.5 % of the total number of lengths for DN 65 to DN 100 inclusive and 5 % for all other sizes.

2) *Mill lengths.* When mill lengths are required tubes shall be supplied in lengths of 6.4 m minimum. No tube shall exceed this length by more than 150 mm.

3) *Approximate lengths.* Where approximate lengths are required, either for screwed and socketed tubes or for plain end tubes, each tube shall be within  $\pm 150$  mm of the specified length.

4) *Exact lengths.* Where exact lengths are required, either for screwed and socketed tubes or for plain end tubes, each tube shall be within  $\begin{matrix} +6 \\ 0 \end{matrix}$  mm of the specified length.

NOTE The purchaser should state in the enquiry or order which lengths he requires (see appendix A).

## Section 3. Testing

### 3.1 Visual inspection

Each tube shall be inspected to ensure compliance with 2.3.

### 3.2 Tensile test

When the tubes are subjected to a tensile test the test shall be in accordance with BS 18-4 and the following requirements shall apply.

The tensile strength,  $R_m$ , the yield strength,  $R_e$  and the elongation,  $A$ , shall be determined and the results obtained shall comply with the requirements given in Table 1. For the yield strength, either the upper yield stress  $R_{eH}$  or the 0.5 % proof stress (total elongation)  $R_t 0.5$  shall be determined.

The percentage elongation shall be reported with reference to a gauge length of  $L_0 = 5.65 \sqrt{S_0}$ . If other gauge lengths are used, the corresponding percentage elongation on  $5.65 \sqrt{S_0}$  shall be obtained by reference to BS 3894-1. In cases of dispute a gauge length of  $5.65 \sqrt{S_0}$  shall be used.

### 3.3 Bend test (whole tube)

The bend test applies to tubes up to and including DN 50. When tested in accordance with the following bend test the finished tubes shall withstand the test without showing any signs of fracture or failure.

The test shall be carried out using a tube bending machine and the tube shall be bent round a grooved former of the radius given in (a) or (b) as appropriate. Tubes shall be bent with the weld at 90° to the plane of bending. The tubes shall not be filled for this test.

a) Tubes which have not been hot-dip zinc coated<sup>2)</sup> shall be bent cold, without cracking, through 180° round a former having a radius at the bottom of the groove equal to six times the outside diameter of the tube as given in Table 3, Table 4 and Table 5.

b) Hot-dip zinc coated<sup>2)</sup> tubes shall be bent cold without cracking of the steel, through 90° round a former having a radius at the bottom of the groove equal to eight times the outside diameter of the tube.

### 3.4 Flattening test

The flattening test applies to tubes greater than DN 50.

When the tubes are tested in accordance with the flattening test the following requirements shall apply.

A ring not less than 40 mm in length taken from one end of each selected tube shall be flattened cold between parallel flat platens without showing either crack or flaw until the distance between the platens, measured under load, is not greater than 75 % of the original outside diameter of the tube and no cracks or flaws in the metal elsewhere than in the weld shall occur until the distance between the platens is less than 60 % of the original outside diameter.

The weld shall be placed at 90° to the direction of flattening.

NOTE Slight premature cracking at the edges would not be deemed to affect compliance with this standard.

### 3.5 Leak tightness test

Each tube shall be tested for leak tightness at the manufacturer's works. The test shall be either a hydraulic test at a pressure of 50 bar<sup>3)</sup>, the pressure being maintained sufficiently long for proof and inspection, or, alternatively, an eddy current test in accordance with appendix B.

NOTE The choice of test is at the discretion of the manufacturer.

### 3.6 Bore test (hot-dip zinc coated tubes only)

When the tubes are tested in accordance with the bore test the following requirement shall apply.

Hot-dip zinc coated tubes of DN 8 up to and including DN 25 shall, after hot-dip zinc coating, have a rod 230 mm in length, of the appropriate diameter specified in Table 2, passed through them and shall have a free bore.

Table 2 — Rod diameters

Nominal size (DN)	Diameter of rod
	mm
8	4.4
10	7.1
15	9.5
20	14.3
25	20.6

### 3.7 Manufacturer's certificate

The manufacturer shall provide for the issue of a certificate which shall certify that the tubes supplied comply with this British Standard.

NOTE This certificate will only be provided when specifically requested by the purchaser in accordance with appendix A.

<sup>2)</sup> Hot-dip zinc coated is synonymous with the term "galvanized".

<sup>3)</sup> 1 bar =  $10^5$  N/m<sup>2</sup> =  $10^5$  Pa.

## Section 4. Protection

### 4.1 General

Tubes shall be supplied varnished unless it is specifically requested by the purchaser in his enquiry or order (see appendix A) that the tubes shall be supplied self colour (i.e. uncoated) or with a hot-dip zinc coating.

### 4.2 Varnish

Where tubes are supplied varnished, they shall be varnished externally over their full length.

### 4.3 Hot-dip zinc coating

Where tubes are supplied hot-dip zinc coated, they shall first be thoroughly descaled, washed as necessary and then dipped in a bath of molten zinc, containing not less than 98.5 % by mass of zinc, at a temperature suitable to produce a complete and uniformly adherent coating of zinc.

Tubes which are to be screwed shall be hot-dip zinc coated before screwing.

When the hot-dip zinc coating is required to be tested, one tube per batch of 500 shall be tested in accordance with appendix C.

NOTE The purchaser should state in the enquiry or order whether a test on the hot-dip zinc coating is required (see appendix A).

### 4.4 Threads

For tubes supplied in the self colour condition the threads shall be unprotected unless it is specifically requested by the purchaser in his enquiry or order (see appendix A) that the threads shall be supplied protected.

For tubes supplied varnished or hot-dip zinc coated the threads shall be given a protective coating.

## Section 5. Tubulars

### 5.1 General

Tubulars shall be made from tubes which comply with all of the appropriate requirements of section two of this standard and shall be screwed with BS 21 taper or parallel threads as shown in Figure 2 to Figure 7.

### 5.2 Sockets

Sockets for tubulars shall have parallel threads which comply with BS 21 unless it is specifically requested by the purchaser in his enquiry or order (see appendix A) that the sockets shall be supplied with taper threads which comply with BS 21.

Dimensions of sockets shall be as given in Table 6.

NOTE A socket is shown in Figure 1.

### 5.3 Pieces

The dimensions of pieces shall be as given in Table 7.

NOTE A piece is shown in Figure 2.

### 5.4 Nipples

Close taper and running nipples shall be made only from heavy tube. Barrel nipples shall be made only from medium or heavy tube.

The dimensions of nipples shall be as given in Table 8.

NOTE Nipples are shown in Figure 3.

### 5.5 Longscrews

Longscrews shall be made only from heavy tube, shall be supplied single or double and the dimensions shall be as given in Table 9.

NOTE 1 Longscrews are shown in Figure 4 and Figure 5.

NOTE 2 The purchaser should state in the enquiry or order whether single or double longscrews are required (see appendix A).

The sockets shall be suitably faced on the end against which the backnut abuts. The face of the backnut which abuts against the socket shall be concave at an angle of approximately 5°.

NOTE 3 The use of longscrews for running joints is permissible for low pressures, but is not recommended for higher pressure service or for applications in which there are wide fluctuations of temperature.

The parallel thread on the longscrew and in the socket and backnut shall comply with the appropriate requirements of BS 21.

NOTE 4 This requires the thread to be of such size that the socket and backnut will run on the longscrew hand-tight without perceptible shake.

### 5.6 Bends and springs

Though not critical, the approximate dimensions of bends and springs shall be as given in Table 10. The angular tolerance in all cases shall be  $\pm 1.5^\circ$ .

Type 1 bends and type 2, 3 and 4 springs shall not be made from light tube. Type 1A bends shall be made only from heavy tube and, in addition to having the approximate dimensions as given in Table 10, shall be fitted with sockets and backnuts complying with 5.5.

All threads shall be taper threads in accordance with BS 21 series R except that one end of type 1A bends as shown in Figure 6 b) shall have parallel threads in accordance with BS 21 series R<sub>L</sub>.

NOTE Bends and springs are shown in Figure 6.

### 5.7 Return bends

Return bends shall be made only from heavy tube. Though not critical, the approximate dimensions shall be as given in Table 11. The ends of the bend shall be parallel within  $\pm 1.5^\circ$ .

NOTE A return bend is shown in Figure 7.

### 5.8 Protection

Protection for tubulars shall be as specified, for tubes in section four.

## Section 6. Marking

### 6.1 Tubes and tubulars

Before dispatch from the manufacturer's works all tubes and tubulars shall be marked with the appropriate colour as follows.

Light tubes (see Table 3)            brown  
Medium tubes (see Table 4)        blue

Heavy tubes (see Table 5)        red

Tubes less than 4 m in length shall have one colour band.

Tubes of 4 m to 7 m length shall have two colour bands, one near each end. These bands shall be approximately 50 mm wide.

**Table 3 — Dimensions of steel tubes: light**

Nominal size (DN)	Designation of thread	Outside diameter		Thickness	Mass of black tube	
		max.	min.		Plain end	Screwed and socketed
		mm	mm	mm	kg/m	kg/m
8	1/4	13.6	13.2	1.8	0.515	0.519
10	3/8	17.1	16.7	1.8	0.670	0.676
15	1/2	21.4	21.0	2.0	0.947	0.956
20	3/4	26.9	26.4	2.3	1.38	1.39
25	1	33.8	33.2	2.6	1.98	2.00
32	1 1/4	42.5	41.9	2.6	2.54	2.57
40	1 1/2	48.4	47.8	2.9	3.23	3.27
50	2	60.2	59.6	2.9	4.08	4.15
65	2 1/2	76.0	75.2	3.2	5.71	5.83
80	3	88.7	87.9	3.2	6.72	6.89
100	4	113.9	113.0	3.6	9.75	10.0

NOTE Dimensions and masses are in accordance with ISO 65 (light series 2).

**Table 4 — Dimensions of steel tubes: medium**

Nominal size of thread (DN)	Designation of thread	Outside diameter		Thickness	Mass of black tube	
		max.	min.		Plain end	Screwed and socketed
		mm	mm	mm	kg/m	kg/m
8	1/4	13.9	13.3	2.3	0.641	0.645
10	3/8	17.4	16.8	2.3	0.839	0.845
15	1/2	21.7	21.1	2.6	1.21	1.22
20	3/4	27.2	26.6	2.6	1.56	1.57
25	1	34.2	33.4	3.2	2.41	2.43
32	1 1/4	42.9	42.1	3.2	3.10	3.13
40	1 1/2	48.8	48.0	3.2	3.57	3.61
50	2	60.8	59.8	3.6	5.03	5.10
65	2 1/2	76.6	75.4	3.6	6.43	6.55
80	3	89.5	88.1	4.0	8.37	8.54
100	4	114.9	113.3	4.5	12.2	12.5
125	5	140.6	138.7	5.0	16.6	17.1
150	6	166.1	164.1	5.0	19.7	20.3

NOTE Maximum and minimum outside diameters meet the requirements of ISO 65.

Table 5 — Dimensions of steel tubes: heavy

Nominal size (DN)	Designation of thread	Outside diameter		Thickness	Mass of black tube	
		max.	min.		Plain end	Screwed and socketed
		mm	mm	mm	kg/m	kg/m
8	1/4	13.9	13.3	2.9	0.765	0.769
10	3/8	17.4	16.8	2.9	1.02	1.03
15	1/2	21.7	21.1	3.2	1.44	1.45
20	3/4	27.2	26.6	3.2	1.87	1.88
25	1	34.2	33.4	4.0	2.94	2.96
32	1 1/4	42.9	42.1	4.0	3.80	3.83
40	1 1/2	48.8	48.0	4.0	4.38	4.42
50	2	60.8	59.8	4.5	6.19	6.26
65	2 1/2	76.6	75.4	4.5	7.93	8.05
80	3	89.5	88.1	5.0	10.3	10.5
100	4	114.9	113.3	5.4	14.5	14.8
125	5	140.6	138.7	5.4	17.9	18.4
150	6	166.1	164.1	5.4	21.3	21.9

NOTE Maximum and minimum outside diameters meet the requirements of ISO 65.

Table 6 — Sockets (see Figure 1)

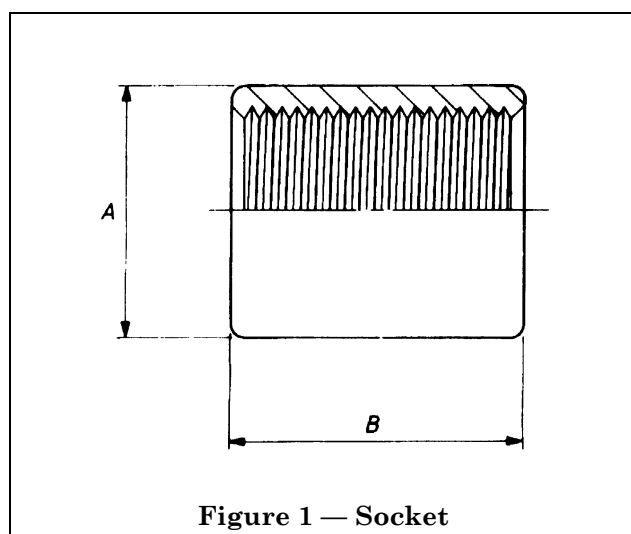

Figure 1 — Socket

Nominal size (DN)	Designation of thread	Minimum outside diameter A	Minimum length B
		mm	mm
8	1/4	18.5	27
10	3/8	22	28
15	1/2	27	37
20	3/4	32.5	39
25	1	39.5	46
32	1 1/4	49	51
40	1 1/2	56	51
50	2	68	60
65	2 1/2	84	69
80	3	98	75
100	4	124	87
125	5	151	96
150	6	178	96

NOTE 1 The socket lengths shown in Table 6 meet the requirements of ISO 50, but the minimum length,  $B$ , has been increased to allow for the chamfer at the ends of the socket and is based on:

$$B = 2L + 3.5P$$

where

$L$  is the length of useful thread on pipe end (see column 13 of Table 2 of BS 21:1985);

$P$  is the pitch of thread.

NOTE 2 For minimum length of faced sockets see Table 9.

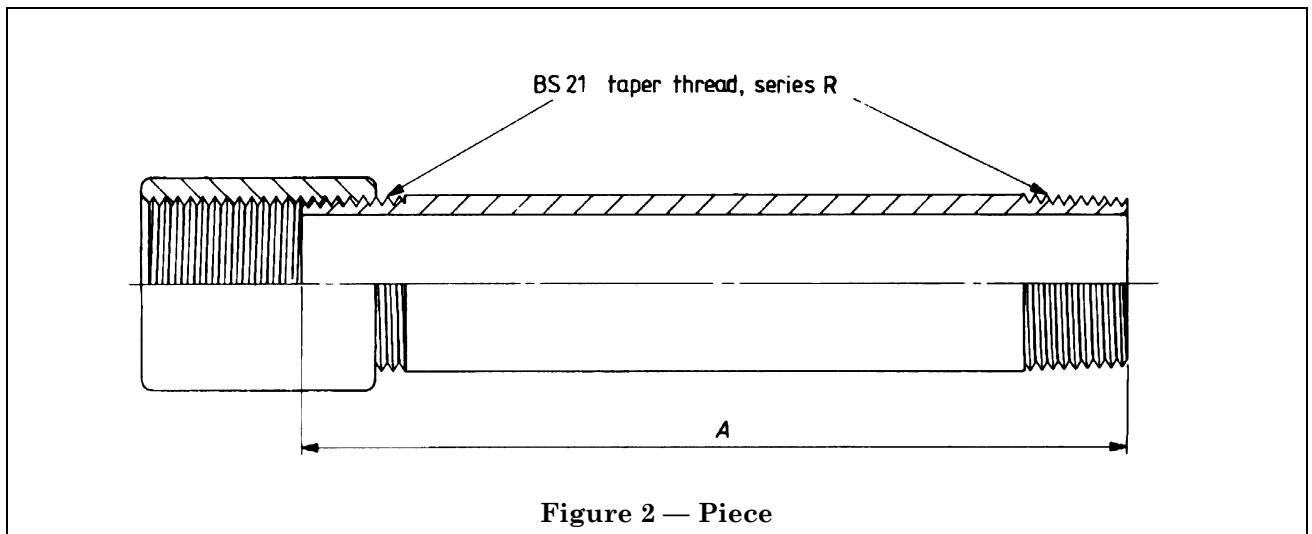

Table 7 — Pieces (see Figure 2)

Nominal size (DN)	Designation of thread	Standard lengths A			
		mm	mm	mm	mm
8	1/4	100	150	200	250
10	3/8	100	150	200	250
15	1/2	100	150	200	250
20	3/4	100	150	200	250
25	1	100	150	200	250
32	1 1/4	150	200	250	300
40	1 1/2	150	200	250	300
50	2	150	200	250	300
65	2 1/2	150	200	250	300
80	3	200	250	300	400
100	4	250	250	300	400
125	5	250	300	400	500
150	6	250	300	400	500

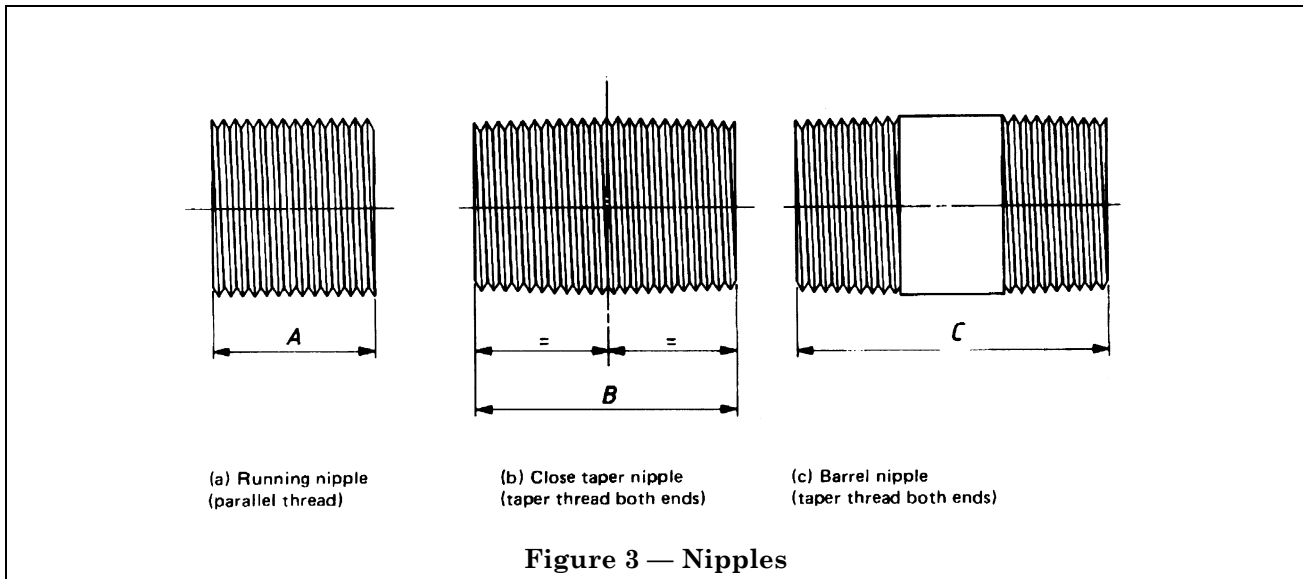

Figure 3 — Nipples

Table 8 — Running nipples, close taper nipples and barrel nipples (see Figure 3)

Nominal size of thread (DN)	Designation of thread	Lengths					
		Running nipple		Close taper nipple		Barrel nipple	
		A (min.)	Tolerance	B (min.)	Tolerance	C (min.)	Tolerance
		mm	mm	mm	mm	mm	mm
8	$\frac{1}{4}$	19		27		38	
10	$\frac{3}{8}$	21		28		38	+3
15	$\frac{1}{2}$	27		37		51	
20	$\frac{3}{4}$	30	+1.5	39	+1.5	54	+4.5
25	1	33		46		60	
32	$1 \frac{1}{4}$	38		51		70	
40	$1 \frac{1}{2}$	38		51		70	+6
50	2	48		60		79	
65	$2 \frac{1}{2}$	51		69		89	
80	3	57	+3	75	+3	102	+8
100	4	70		87		114	
125	5	78		96		124	
150	6	78		96		127	



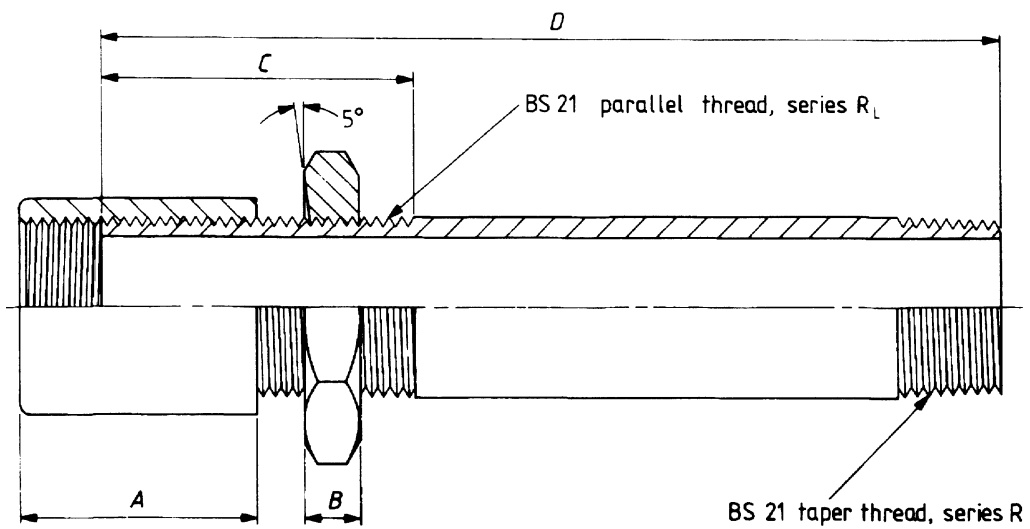

Figure 4 — Single long screw

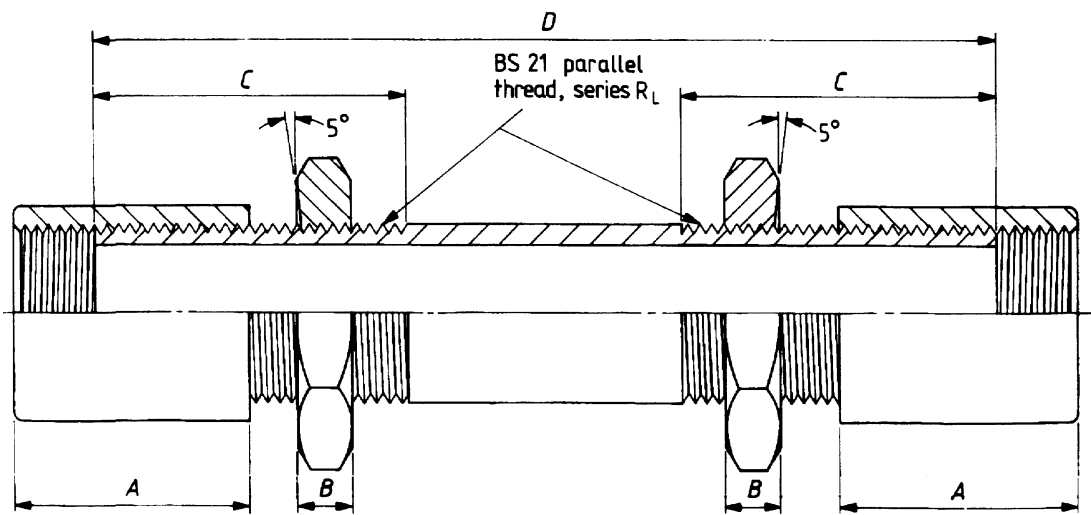

Figure 5 — Double long screw

**Table 9 — Longscrews** (see Figure 4 and Figure 5)

Nominal size (DN)	Designation of thread	Faced socket		Hexagon backnut				Minimum useful length of long thread <i>C</i>	Standard lengths <i>D</i>			
		Minimum length <i>A</i>	Tolerance on length	Nominal width across flats	Tolerance on width across flats	Minimum thickness <i>B</i>	Tolerance on thickness		mm	mm	mm	mm
8	1/4	25	+1.5	19		6.5		37	100	150	200	250
10	3/8	25		24		7		40	100 <sup>a</sup>	150	200	250
15	1/2	35		30		8		52	100 <sup>a</sup>	150	200	250
20	3/4	37	+3	36	±0.8	9	+1.5	54	100 <sup>a</sup>	150	200	250
25	1	43		41		9.5		62	100 <sup>a</sup>	150	200	250
32	1 1/4	48		50		11		70	150 <sup>a</sup>	200	250	300
40	1 1/2	48	+4.5	60		12		71	150 <sup>a</sup>	200	250	300
50	2	57		70		13		82	150 <sup>a</sup>	200 <sup>a</sup>	250	300
65	2 1/2	65		90		17		97	150 <sup>a</sup>	200 <sup>a</sup>	250	300
80	3	71		100		21		106	200 <sup>a</sup>	250 <sup>a</sup>	300	400
100	4	84	+6	130	±0.8	22	+3	121	200 <sup>a</sup>	250 <sup>a</sup>	300	400
125	5	92		160		24		130	250 <sup>a</sup>	300 <sup>a</sup>	400	500
150	6	92		190		25		132	250 <sup>a</sup>	300 <sup>a</sup>	400	500

<sup>a</sup> Double longscrews cannot be supplied in these lengths.

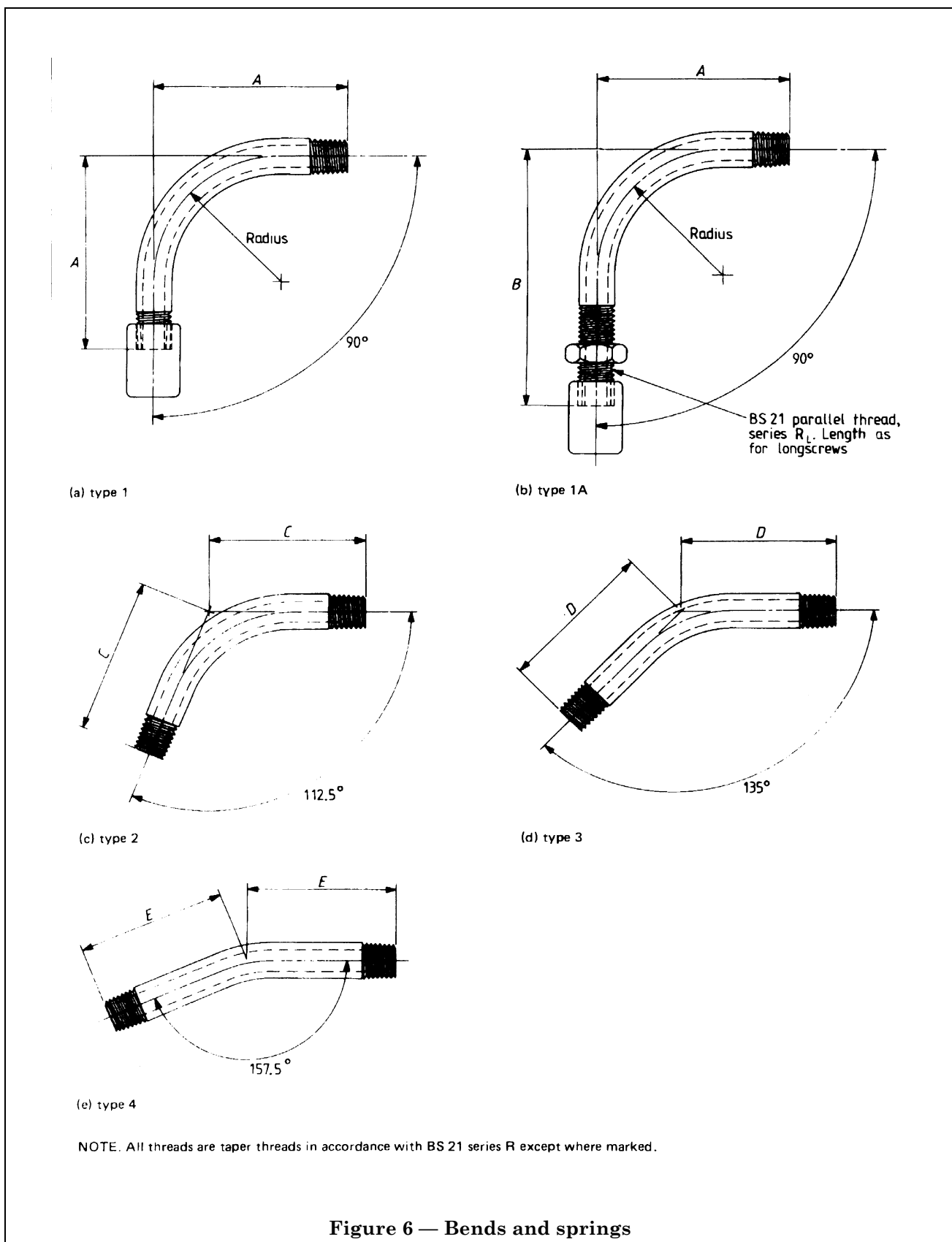
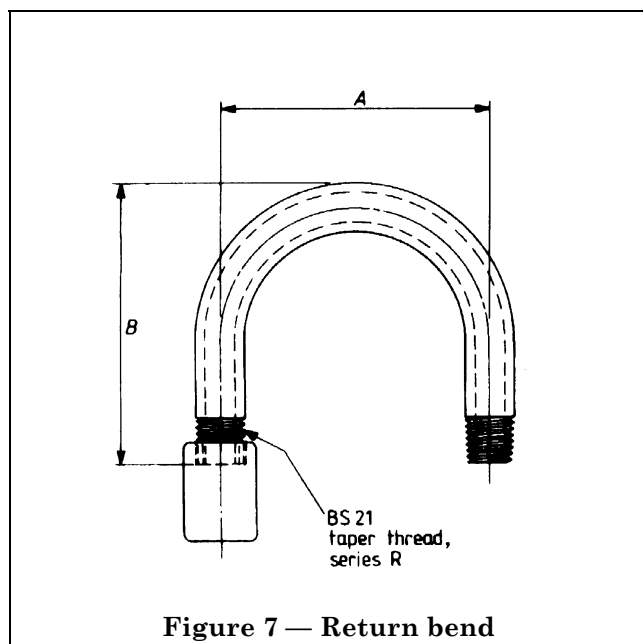

Figure 6 — Bends and springs

Table 10 — Bends and springs (see Figure 6)

Nominal size (DN)	Designation of thread	Dimensions (approximate)					
		Bends		Radius	Springs		
		90°			112.5°	135°	157.5°
		Centre to face			Centre to face		
		A	B	R	C	D	E
mm	mm	mm	mm	mm	mm		
8	1/4	64	92	41	60	57	54
10	3/8	73	105	48	67	64	60
15	1/2	86	127	57	79	76	73
20	3/4	102	143	73	92	89	86
25	1	121	168	89	108	105	102
32	1 1/4	146	197	108	133	127	124
40	1 1/2	165	219	127	149	143	140
50	2	203	264	159	181	175	168
65	2 1/2	248	321	197	222	213	206
80	3	292	371	232	260	248	241
100	4	381	467	308	340	324	318
125	5	540	632	—	476	457	444
150	6	622	718	—	572	540	527

Table 11— Return bends (see Figure 7)



Nominal size (DN)	Designation of thread	Dimensions (approximate)	
		Centres A	Back to face B
		mm	mm
8	1/4	51	64
10	3/8	64	70
15	1/2	89	102
20	3/4	102	121
25	1	114	140
32	1 1/4	127	152
40	1 1/2	165	178
50	2	190	210
65	2 1/2	305	292
80	3	356	330
100	4	457	400
125	5	762	578
150	6	914	692

## Appendix A Information to be supplied by the purchaser in the enquiry or order

The following information should be supplied by the purchaser in his enquiry or order:

- a) the number of this British Standard, i.e. BS 1387, tube nominal size (DN), thickness series (see 1.3) and quantity required;
- b) type of end finish of tubes (see 1.3);
- c) tubular nominal size (DN), thickness series, type and length where appropriate (see 1.3.2) and quantity required;

This standard allows a number of options and the purchaser may also state in his enquiry or order his requirements as follows. Where no such statement is made, supply will be as specified in this standard.

- 1) whether tubes are to be supplied without sockets (see 2.4);
- 2) whether sockets are to have taper threads (see 2.4 and 5.2);
- 3) whether tubes are required in random lengths, mill lengths, approximate lengths or exact lengths [see 2.5.2 d)];
- 4) whether a manufacturer's certificate is required (see 3.7);
- 5) whether tubes or tubulars should be supplied in the self colour (uncoated) condition (see 4.1 and 5.8);
- 6) whether tubes or tubulars are to be hot-dip zinc coated (see 4.1, 4.3 and 5.8);
- 7) whether a test on the hot-dip zinc coating is required (see 4.3);
- 8) whether threads of tubes or tubulars should be protected (see 4.4 and 5.8);
- 9) whether single or double long screws are required (see 5.5).

## Appendix B Eddy current testing of tubes as an alternative to the hydraulic leak tightness test

### B.1 Methods of test

**B.1.1** The tubes shall be tested for imperfections using a concentric coil or a rotating tube or rotary probe eddy current technique in accordance with this appendix.

**B.1.2** The tube shall be sufficiently straight to ensure the validity of the test and the surfaces shall be free from any foreign matter that would interfere with the interpretation of the test.

**B.1.3** Two methods of test are permitted, the choice being at the option of the manufacturer.

- a) *Method A*, in which the tube to be tested is passed through the concentric test coil.
- b) *Method B*, in which the tube to be tested or the test coil assembly is rotated and translated relative to the other so the test coil describes a helical path over the tube surface. The pitch of the helical scan shall ensure that the whole of the tube surface is covered.

### B.2 Calibration of test equipment

**B.2.1** The equipment shall be calibrated using a test piece containing either reference holes as described in B.2.3 for method A, or a reference notch as described in B.2.4 for method B.

**B.2.2** The test piece shall have similar electromagnetic properties and the same diameter and thickness as the tube to be tested.

**B.2.3** For method A, the test piece shall have three circular holes drilled radially through the tube wall. The holes shall be circumferentially displaced 120° from each other and sufficiently separated longitudinally from each other and the extremities of the test piece so that clearly distinguishable signal indications are obtained. Use a drill with the appropriate diameter given in Table 12 to produce the reference holes.

Table 12 — Drill diameters

Outside diameter of tube mm	Drill diameter mm
≤ 25	1.2
> 25 ≤ 45	1.7
> 45 ≤ 65	2.2
> 65 ≤ 100	2.7
> 100 ≤ 140	3.2
> 140 ≤ 180	3.7

**B.2.4** For method B, the surface of the test piece that will be adjacent to the test coils shall contain a parallel sided notch formed parallel to the longitudinal axis of the tubular test piece. The dimensions of the notch shall be as follows.

- (a) Width: Not greater than notch depth with a minimum of 0.50 mm.
- (b) Depth: 12.5 % of the specified thickness with a minimum of 0.6 mm. The tolerance on the depth shall be  $\pm 15\%$ .
- (c) Length: A convenient length selected by the manufacturer for calibration and checking purposes.

### B.3 Calibration procedures

**B.3.1** The equipment and test coils shall be adjusted to produce in a consistent manner a clearly identifiable signal from the reference standard(s) and this signal shall be used to set the trigger/alarm level of the equipment. For calibration purposes the relative speed between the test piece containing the reference standard(s) and the test coils shall be the same as that used during the production test.

**B.3.2** The calibration of the equipment shall be checked at the commencement and at the end of each working period and at intervals not exceeding 2 h.

**B.3.3** If on checking during production testing the reference standard is not detected even after changing the sensitivity by 2 dB to allow for equipment drift, the equipment shall be recalibrated. Following recalibration, all tubes tested since the previous check shall be retested, unless recordings from individually identified tubes are available that permit classification of those tubes into "suspect" and "acceptable" categories.

**C.2.4** *Copper (II) sulphate test solution*, having the following composition:

### B.4 Test procedure

Pass the pipe or tubing to be inspected through the test unit at the appropriate production speed, maintaining the production speed constant within  $\pm 10\%$ , under conditions identical to those used in the calibration of the equipment.

**NOTE** Identical conditions include all instrument settings, mechanical motion, positioning of the encircling coil(s) in relation to the tube and any other factor that affects the validity of the technique.

### B.5 Assessment of results

**B.5.1** Any tube that does not produce signals giving the trigger/alarm condition shall be deemed to have passed the test.

**B.5.2** Any tube that produces a signal giving the trigger/alarm condition shall be either designated suspect or, at the manufacturer's option, retested.

**B.5.3** If upon retesting no signal giving a trigger/alarm condition is obtained the tube shall be deemed to have passed the test. Tubes giving a trigger/alarm condition shall be designated suspect.

**B.5.4** For suspect tube one or other of the following actions shall be taken.

- a) Crop off the suspect area. The remaining length shall be deemed to have passed the test.
- b) The tube shall be deemed not to have passed the test.

## Appendix C Method for testing the zinc coatings on hot-dip zinc coated tubes and tubulars (copper sulphate test)

### C.1 Principle

A clean hot-dip zinc coated tube sample is immersed four times in a solution of copper sulphate and the tube is examined for adherent deposits of metallic copper.

### C.2 Reagents

**C.2.1** *General*. Test solutions shall be made using reagents of recognized quality and only distilled water or water of equivalent purity.

**C.2.2** *Sulphuric acid* (dilute solution), having the following volumetric composition:

- a)  $\text{H}_2\text{SO}_4$  (p 1.84 g/mL at 20 °C): 1 volume
- b)  $\text{H}_2\text{O}$ : 50 volumes

**C.2.3** *Hydrochloric acid* (dilute solution), having the following volumetric composition:

- a)  $\text{HCl}$  (p 1.19 g/mL at 20 °C): 1 volume
- b)  $\text{H}_2\text{O}$ : 10 volumes
- a)  $\text{CuSO}_4 \cdot 5\text{H}_2\text{O}$ : 33 g

b) H<sub>2</sub>O: 100 mL

To the copper (II) sulphate test solution add an excess of copper carbonate or copper hydrate and shake. Filter the test solution or allow it to settle before use.

The test solution shall have a relative density of 1.170 at 15 °C.

### C.3 Apparatus

**C.3.1 Bath**, being sufficiently large to accommodate the length of tube to be immersed and to give a clearance of at least 25 mm between the test sample(s) and the wall of the bath. The material of the bath shall be inert to the copper sulphate test solution.

**C.3.2 Plugs**, when required, of inert material for insertion into the tubes.

### C.4 Test sample

The test sample shall comprise a length of hot-dip zinc coated tube at least sufficient to give the length immersed given in Table 13.

**Table 13 — Length immersed and volume of test solution**

Nominal size (DN)	Length immersed (min.)	Approximate volume of test solution required
	mm	mL
8	200	600
10	200	700
15	200	800
20	200	900
25	180	900
32	180	1 100
40	180	1 200
50	150	1 400
65	125	1 500
80	100	1 400 <sup>a</sup>
100	100	2 000 <sup>a</sup>
125	75	2 000 <sup>a</sup>
150	75	2 000 <sup>a</sup>

<sup>a</sup> Assuming the use of a plug of inert material having a suitable diameter (see C.3.2) inside the bore of the tube.

### C.5 Preparation of test sample

Degrease the sample and wipe it dry with a clean soft cloth. Dip it into the sulphuric acid solution (C.2.2) for 15 s and thoroughly rinse it in clean water. Dry the sample by wiping with a clean soft cloth.

### C.6 Procedure

Immerse the test sample into the copper sulphate test solution (C.2.4) to the length required for its nominal size as given in Table 13 for a duration of 1 min.

NOTE 1 The approximate volume of the test solution is given in Table 13.

Check that the temperature of the test solution does not fall below 15 °C or rise above 21 °C.

Do not agitate the sample or the solution during immersion.

Wholly immerse tubulars that are too short to give the specified immersion length in the test solution.

Remove the sample and immediately rinse it in clean running water, removing any black deposit with a brush and taking care to clean all holes and pockets. Wipe the sample dry and immediately return it to the test solution.

Repeat the procedure until a total of four successive immersions have been made. Wash and dry the test sample.

After each test or batch of tests discard the test solution.

Do not return any used test solution to the stock supply.

NOTE 2 When testing tubes of nominal size DN 25 and smaller, more than one test sample may be immersed in the same bath of test solution, provided that a clearance of at least 25 mm between test samples and the bath is maintained.

NOTE 3 When testing tubes of nominal size DN 80 or larger, economy in the use of the test solution may be achieved by the use of a plug of inert material placed inside the tube.

### C.7 Examination

The dry test sample shall be examined for deposits of red metallic copper on the hot-dip zinc coating.

NOTE It is permissible to test the adherence of any such deposits by peeling, light rubbing or by immersion in the solution of hydrochloric acid (C.2.3) for 15 s, followed by immediate rinsing in clean running water together with vigorous scrubbing.

### **C.8 Conditions of compliance**

After the four successive immersions in the test solution, the test sample shall not show any adherent red deposits of metallic copper on the hot-dip zinc coating after the final rinsing and wiping dry. Any such deposit of metallic copper within 25 mm of the end of the tube or any cut edge or surface shall be deemed not to affect compliance with this standard.

If the metallic copper adhesion test, described in the note to **C.7**, is carried out and the copper has been removed and zinc is seen underneath, then the test sample shall be deemed to comply.

### **C.9 Results**

The manufacturer shall record the results of the test.



---

## Publications referred to

BS 18, *Methods for tensile testing of metals.*

BS 18-4, *Steel tubes.*

BS 21, *Specification for pipe threads for tubes and fittings where pressure-tight joints are made on the threads (metric dimensions).*

BS 3894, *Method for converting elongation values for steel.*

BS 3894-1, *Carbon and low alloy steels.*

ISO 50, *Metal pipes — Steel sockets screwed according to ISO 7.*

ISO 65, *Carbon steel tubes suitable for screwing in accordance with ISO 7/1.*

ISO 6708, *Pipe components — Definition of nominal size.*

---

# BSI — British Standards Institution

BSI is the independent national body responsible for preparing British Standards. It presents the UK view on standards in Europe and at the international level. It is incorporated by Royal Charter.

## Revisions

British Standards are updated by amendment or revision. Users of British Standards should make sure that they possess the latest amendments or editions.

It is the constant aim of BSI to improve the quality of our products and services. We would be grateful if anyone finding an inaccuracy or ambiguity while using this British Standard would inform the Secretary of the technical committee responsible, the identity of which can be found on the inside front cover. Tel: 020 8996 9000. Fax: 020 8996 7400.

BSI offers members an individual updating service called PLUS which ensures that subscribers automatically receive the latest editions of standards.

## Buying standards

Orders for all BSI, international and foreign standards publications should be addressed to Customer Services. Tel: 020 8996 9001. Fax: 020 8996 7001.

In response to orders for international standards, it is BSI policy to supply the BSI implementation of those that have been published as British Standards, unless otherwise requested.

## Information on standards

BSI provides a wide range of information on national, European and international standards through its Library and its Technical Help to Exporters Service. Various BSI electronic information services are also available which give details on all its products and services. Contact the Information Centre. Tel: 020 8996 7111. Fax: 020 8996 7048.

Subscribing members of BSI are kept up to date with standards developments and receive substantial discounts on the purchase price of standards. For details of these and other benefits contact Membership Administration. Tel: 020 8996 7002. Fax: 020 8996 7001.

## Copyright

Copyright subsists in all BSI publications. BSI also holds the copyright, in the UK, of the publications of the international standardization bodies. Except as permitted under the Copyright, Designs and Patents Act 1988 no extract may be reproduced, stored in a retrieval system or transmitted in any form or by any means – electronic, photocopying, recording or otherwise – without prior written permission from BSI.

This does not preclude the free use, in the course of implementing the standard, of necessary details such as symbols, and size, type or grade designations. If these details are to be used for any other purpose than implementation then the prior written permission of BSI must be obtained.

If permission is granted, the terms may include royalty payments or a licensing agreement. Details and advice can be obtained from the Copyright Manager. Tel: 020 8996 7070.