

Specification for

# Aluminium and aluminium alloy ingots and castings for general engineering purposes

UDC 669.71- 412-14:621

# Committees responsible for this British Standard

The preparation of this British Standard was entrusted by the Non-ferrous Metals Standards Committee (NFM/-) to Technical Committee NFM/35, upon which the following bodies were represented:

Aluminium Federation  
 Aluminium Stockholders' Association  
 Association of Light Alloy Refiners Limited  
 Department of Trade and Industry (Minerals and Metals Division)  
 Light Metal Founders' Association  
 Magnesium Industry Council  
 Royal Institute of British Architects  
 Society of Motor Manufacturers and Traders Limited

The following bodies were also represented in the drafting of the standard, through subcommittees and panels:

BNF Metals Technology Centre  
 British Foundry Association  
 British investment Casting Trade Association  
 Institute of British Foundrymen

This British Standard, having been prepared under the direction of the Non-ferrous Metals Standards Committee, was published under the authority of the Board of BSI and comes into effect on 30 June 1988

© BSI 12-1998

First published, August 1949  
 First revision October 1955  
 Second revision May 1963  
 Third revision December 1970  
 Fourth revision June 1988

The following BSI references relate to the work on this standard:  
 Committee reference NFM/35  
 Draft for comment 86/39422 DC

ISBN 0 580 16575 2

## Amendments issued since publication

Amd. No.	Date of issue	Comments
6309	March 1990	
6605	December 1990	Indicated by a sideline in the margin

# Contents

	Page
Committees responsible	Inside front cover
Foreword	ii
<hr/>	
1 Scope	1
2 Definitions	1
3 General requirements	2
4 Specific requirements for ingots	2
5 Specific requirements for castings	6
6 Inspection procedures	6
7 Test samples	8
8 Test methods	9
<hr/>	
Appendix A Information to be supplied by the purchaser	15
Appendix B Recommendations for optional supplementary inspection and tests for castings	15
Appendix C Colour code for ingots	18
Appendix D Guide to the selection of alloys	18
<hr/>	
Figure 1 — Sand or chill cast test samples: forms A and B	9
Figure 2 — Chill cast test samples: forms C and D	10
Figure 3 — Sand cast test sample: form E	11
Figure 4 — Sand cast test sample: form F	12
Figure 5 — Investment cast test sample: form G (“cast to size”)	13
Figure 6 — Investment cast test sample: form H	14
<hr/>	
Table 1 — Chemical compositions of group A ingots and castings: general purpose alloys	3
Table 2 — Chemical compositions of group B ingots and castings: special purpose alloys	4
Table 3 — Chemical compositions of group C ingots and castings: special purpose alloys of limited application	5
Table 4 — Mechanical properties for castings (obtained on separately cast test samples)	7
Table 5 — Hardness of castings	8
Table 6 — Colour code for ingots	18
Table 7 — Machinability ratings of aluminium casting alloys	21
Table 8 — Comparison of casting characteristics and other properties	24
<hr/>	
Publications referred to	Inside back cover
<hr/>	

# Foreword

This British Standard has been prepared under the direction of the Non-ferrous Metals Standards Committee. It is the fourth revision of BS 1490, which was originally published in 1949 and subsequently revised in 1955, 1963 and 1970. It supersedes the 1970 edition, which is withdrawn.

In this revision, two of the alloys in the previous edition, LM10 and LM18, have been omitted. One new alloy, LM31, has been introduced and its requirements are based on those of DTD 5008 B. Slight changes have been made to the magnesium content permitted in LM4 and LM27 and in the copper content permitted in LM25 and LM9. Limits have been imposed on the permitted level of unnamed impurities in the alloys.

Requirements have been introduced for the frequency of analysis of ingots and for the frequency of tensile testing of castings, other than pressure die castings. Three additional mould designs for casting tensile test samples have been introduced, two of these being specifically for investment cast samples.

A new appendix B "Recommendations for optional supplementary inspection and tests for castings" is included, based on section 2 of the last edition, but completely revised to take account of current procedures and to relate to the similar appendix in BS 1400. The "Colour code for ingots" of the previous edition has been retained in this revision as appendix C and is unchanged apart from the inclusion of a colour code for the new alloy LM31. Section 3 of the last edition, which was a guide for the user to the selection of alloys for the manufacture of castings, has been completely revised and included as appendix D.

In previous editions of this standard, clauses have been included entitled "Inspection", "Independent test" and "Facilities for testing". As these clauses are contractual and not relevant to a product standard, they have been omitted from this revision.

A British Standard does not purport to include all the necessary provisions of a contract. Users of British Standards are responsible for their correct application.

**Compliance with a British Standard does not of itself confer immunity from legal obligations.**

## Summary of pages

This document comprises a front cover, an inside front cover, pages i and ii, pages 1 to 24, an inside back cover and a back cover.

This standard has been updated (see copyright date) and may have had amendments incorporated. This will be indicated in the amendment table on the inside front cover.

## 1 Scope

This British Standard specifies requirements for the chemical compositions, mechanical properties and other characteristics for the following two types of product for general engineering purposes:

- a) aluminium and aluminium alloy ingots intended to be remelted for the production of castings; and
- b) aluminium and aluminium alloy castings.

Methods for verifying that ingots and castings comply with this British Standard are also specified.

NOTE 1 This standard is intended to apply to castings made by any metal casting process. However, in the case of mechanical properties, requirements are specified only for castings made by the sand casting, chill casting and investment casting processes.

NOTE 2 Information which purchasers are recommended to provide in any enquiry or order is given in appendix A. Recommendations for optional supplementary inspection and test procedures, that enable castings to be ordered according to particular inspection and test requirements appropriate to the application of the castings, are given in appendix B.

Appendix B also describes a system of inspection coding that enables the additional inspection and test procedures to be specified readily at the design stage, for quotation purposes and for order.

NOTE 3 The titles of the publications referred to in this standard are listed on the inside back cover.

## 2 Definitions

For the purposes of this British Standard the following definitions apply.

### 2.1

#### **ingot**

a cast, unwrought product, in a form suitable for remelting

### 2.2

#### **casting**

a product at or near finished shape, formed by solidification of a metal or alloy in a mould

### 2.3

#### **sand casting**

a casting formed in a sand mould

### 2.4

#### **chill casting**

a casting formed in a metal mould

### 2.5

#### **gravity die casting**

a chill casting in which the molten metal is introduced by gravity

### 2.6

#### **low pressure die casting**

a chill casting in which the molten metal is introduced by a low pressure feed

### 2.7

#### **pressure die casting**

a chill casting in which the molten metal is introduced under high pressure

### 2.8

#### **investment casting**

a casting formed from an expendable pattern which has been invested in a suitable mould material

### 2.9

#### **cast (non-continuous melting)**

the product of either one furnace melt, or a number of furnace melts where such are aggregated and mixed prior to sampling or pouring

### 2.10

#### **cast (continuous melting)**

in continuous melting for the production of castings, when the contents of a melting/holding furnace are supplemented from time to time by the addition of metal to maintain an adequate bulk of liquid metal, a cast is 500 kg or fraction thereof of metal poured

### 2.11

#### **approved ingots**

aluminium and aluminium alloy ingots which have been proved to comply with the appropriate material specification

### 2.12

#### **approved scrap**

that scrap which arises from a founder's own production from approved ingots, which is segregated and identifiable. It may include heavy fettling scrap but be free of all drosses and small particles such as sawings, grindings and chippings

### 2.13

#### **ingot batch**

a series of ingots cast from a single uniform melt

### 3 General requirements

Aluminium and aluminium alloy ingots shall comply with clause 4.

Aluminium and aluminium alloy castings shall comply with clause 5.

Inspection procedures and test methods for verifying that the ingots and castings comply with clauses 4 and 5 shall be as specified in clauses 6, 7 and 8.

NOTE Castings ordered to be subject to optional supplementary inspection and testing requirements (see appendix B) should also comply with the recommendations of that appendix.

The results obtained from chemical analysis and tensile tests shall be rounded to the last place of figures specified as limits, by the application of the rounding rules in accordance with BS 1957.

### 4 Specific requirements for ingots

#### 4.1 Chemical composition

The chemical composition of ingots determined on samples taken in accordance with 6.2.1 shall be as given in Table 1 to Table 3 for the appropriate alloy.

#### 4.2 Certificate of analysis

The supplier shall provide a certificate of analysis with each cast of ingots, showing it complies with the analytical requirements of this standard. The certificate shall indicate the full analysis of sample(s) representative of the cast.

#### 4.3 Marking

Ingots shall be marked clearly and durably either:

- a) individually, with the manufacturer's mark, the material designation and the cast number; or
- b) in bundles, with each bundle marked with the manufacturer's mark, the material designation and the cast number.

Ingots shall be colour marked to identify the alloy in which they have been cast.

NOTE Appendix C lists suitable colour codes.

**Table 1 — Chemical compositions of group A ingots and castings: general purpose alloys**

Designation	LM2		LM4		LM6		LM20		LM24		LM25		LM27	
Nominal composition	Al-Si10Cu2		Al-Si5Cu3Mn0.5		Al-Si12		Al-Si12		Al-Si8Cu3.5		Al-Si7Mg0.5		Al-Si7Cu2Mn0.5	
Nearest alloy(s) in ISO 3522	—		Al-Si5Cu3		Al-Si12 Al-Si12CuFe		Al-Si12Cu Al-Si12Fe		Al-Si8Cu3Fe		Al-Si7Mg		Al-Si5Cu3	
Elements	min.	max.	min.	max.	min.	max.	min.	max.	min.	max.	min.	max.	min.	max.
	%	%	%	%	%	%	%	%	%	%	%	%	%	%
Aluminium	Remainder		Remainder		Remainder		Remainder		Remainder		Remainder		Remainder	
Copper	<b>0.7</b>	<b>2.5</b>	<b>2.0</b>	<b>4.0</b>	—	0.1	—	0.4	<b>3.0</b>	<b>4.0</b>	—	0.20	<b>1.5</b>	<b>2.5</b>
Magnesium	—	0.30	—	0.20	—	0.10	—	0.2	—	0.30	<b>0.20</b>	<b>0.6</b>	—	0.35
Silicon	<b>9.0</b>	<b>11.5</b>	<b>4.0</b>	<b>6.0</b>	<b>10.0</b>	<b>13.0</b>	<b>10.0</b>	<b>13.0</b>	<b>7.5</b>	<b>9.5</b>	<b>6.5</b>	<b>7.5</b>	<b>6.0</b>	<b>8.0</b>
Iron	—	1.0	—	0.8	—	0.6	—	1.0	—	1.3	—	0.5	—	0.8
Manganese	—	0.5	<b>0.2</b>	<b>0.6</b>	—	0.5	—	0.5	—	0.5	—	0.3	<b>0.2</b>	<b>0.6</b>
Nickel	—	0.5	—	0.3	—	0.1	—	0.1	—	0.5	—	0.1	—	0.3
Zinc	—	2.0	—	0.5	—	0.1	—	0.2	—	3.0	—	0.1	—	1.0
Lead	—	0.3	—	0.1	—	0.1	—	0.1	—	0.3	—	0.1	—	0.2
Tin	—	0.2	—	0.1	—	0.05	—	0.1	—	0.2	—	0.05	—	0.1
Titanium	—	0.2	—	0.2	—	0.2	—	0.2	—	0.2	—	0.2 <sup>a</sup>	—	0.2
Each other element <sup>b</sup>	—	—	—	0.05	—	0.05	—	0.05	—	—	—	0.05	—	0.05
Total other elements <sup>b</sup>	—	0.50	—	0.15	—	0.15	—	0.20	—	0.50	—	0.15	—	0.15

NOTE Specified impurities are shown in light type. Analysis is required to verify that the contents of the specified impurities are less than the limits given in this table. Analysis for other elements is made when their presence is suspected to be in excess of the "each other element" limit.

<sup>a</sup> If titanium alone is used for grain refining, the amount present shall be not less than 0.05 %.

<sup>b</sup> In cases when alloys are required in the modified condition, the level of any modifying element present is not limited by the specified maximum value for other elements.

Table 2 — Chemical compositions of group B ingots and castings: special purpose alloys

Designation	LM0		LM5		LM9		LM13		LM16		LM21		LM22	
Nominal composition	99.50 + % Al		Al-Mg5Mn0.5		Al-Si12 Mg0.5Mn0.5		Al-Si12Cu1Mg1		Al-Si5Cu1 Mg0.5		Al-Si6Cu4 Mn0.4Mg0.2		Al Si5Cu3 Mn0.4	
Nearest alloy(s) in ISO 3522			Al-Mg5Si1 Al-Mg6		Al-Si10Mg		Al-Si12Cu Al-Si12CuFe		Al-Si5Cu1Mg		Al-Si6Cu4		Al-Si5Cu3	
Elements	min.	max.	min.	max.	min.	max.	min.	max.	min.	max.	min.	max.	min.	max.
	%	%	%	%	%	%	%	%	%	%	%	%	%	%
Aluminium	99.50 <sup>a</sup>	—	Remainder		Remainder		Remainder		Remainder		Remainder		Remainder	
Copper	—	0.03	—	0.1	—	0.20	<b>0.7</b>	<b>1.5</b>	<b>1.0</b>	<b>1.5</b>	<b>3.0</b>	<b>5.0</b>	<b>2.8</b>	<b>3.8</b>
Magnesium	—	0.03	<b>3.0</b>	<b>6.0</b>	<b>0.2</b>	<b>0.6</b>	<b>0.8</b>	<b>1.5</b>	<b>0.4</b>	<b>0.6</b>	<b>0.1</b>	<b>0.3</b>	—	0.05
Silicon	—	0.30	—	0.3	<b>10.0</b>	<b>13.0</b>	<b>10.0</b>	<b>13.0</b>	<b>4.5</b>	<b>5.5</b>	<b>5.0</b>	<b>7.0</b>	<b>4.0</b>	<b>6.0</b>
Iron	—	0.40	—	0.6	—	0.6	—	1.0	—	0.6	—	1.0	—	0.6
Manganese	—	0.03	<b>0.3</b>	<b>0.7</b>	<b>0.3</b>	<b>0.7</b>	—	0.5	—	0.5	<b>0.2</b>	<b>0.6</b>	<b>0.2</b>	<b>0.6</b>
Nickel	—	0.03	—	0.1	—	0.1	—	1.5	—	0.25	—	0.3	—	0.15
Zinc	—	0.07	—	0.1	—	0.1	—	0.5	—	0.1	—	2.0	—	0.15
Lead	—	0.03	—	0.05	—	0.1	—	0.1	—	0.1	—	0.2	—	0.1
Tin	—	0.03	—	0.05	—	0.05	—	0.1	—	0.05	—	0.1	—	0.05
Titanium	—	—	—	0.2	—	0.2	—	0.2	—	0.2 <sup>b</sup>	—	0.2	—	0.2
Each other element <sup>c</sup>	—	—	—	0.05	—	0.05	—	0.05	—	0.05	—	0.05	—	0.05
Total other elements <sup>c</sup>	—	—	—	0.15	—	0.15	—	0.15	—	0.15	—	0.15	—	0.15

NOTE Specified impurities are shown in light type. Analysis is required to verify that the contents of the specified impurities are less than the limits given in this table. Analysis for other elements is made when their presence is suspected to be in excess of the "each other element" limit.

<sup>a</sup> The aluminium content shall be determined by difference, i.e. by subtracting the total of all other elements listed.

<sup>b</sup> If titanium alone is used for grain refining, the amount present shall be not less than 0.05 %.

<sup>c</sup> In cases when alloys are required in the modified condition, the level of any modifying element present is not limited by the specified maximum value for other elements.



**Table 3 — Chemical compositions of group C ingots and castings: special purpose alloys of limited application**

Designation	LM12		LM26		LM28 <sup>a</sup>		LM29 <sup>a</sup>		LM30		LM31 <sup>b</sup>	
Nominal composition	Al-Cu10Mg0.3		Al-Si10Cu3Mg1		Al-Si 18Cu1.5 Mg1Ni1		Al-Si23Cu1 Mg1Ni1		Al-Si17 Cu4.5Mg0.5		Al-Zn5 Mg0.7Cr0.5Ti	
Nearest alloy in ISO 3522											Al-Zn5Mg	
Elements	min.	max.	min.	max.	min.	max.	min.	max.	min.	max.	min.	max.
	%	%	%	%	%	%	%	%	%	%	%	%
Aluminium	Remainder		Remainder		Remainder		Remainder		Remainder		Remainder	
Copper	<b>9.0</b>	<b>11.0</b>	<b>2.0</b>	<b>4.0</b>	<b>1.3</b>	<b>1.8</b>	<b>0.8</b>	<b>1.3</b>	<b>4.0</b>	<b>5.0</b>	—	0.1
Magnesium	<b>0.2</b>	<b>0.4</b>	<b>0.5</b>	<b>1.5</b>	<b>0.8</b>	<b>1.5</b>	<b>0.8</b>	<b>1.3</b>	<b>0.4</b>	<b>0.7</b>	<b>0.5</b>	<b>0.75</b>
Silicon	—	2.5	<b>8.5</b>	<b>10.5</b>	<b>17</b>	<b>20</b>	<b>22</b>	<b>25</b>	<b>16</b>	<b>18</b>	—	0.25
Iron	—	1.0	—	1.2	—	0.7	—	0.7	—	1.1	—	0.5
Manganese	—	0.6	—	0.5	—	0.6	—	0.6	—	0.3	—	0.1
Nickel	—	0.5	—	1.0	<b>0.8</b>	<b>1.5</b>	<b>0.8</b>	<b>1.3</b>	—	0.1	—	0.1
Zinc	—	0.8	—	1.0	—	0.2	—	0.2	—	0.2	<b>4.8</b>	<b>5.7</b>
Lead	—	0.1	—	0.2	—	0.1	—	0.1	—	0.1	—	0.05
Tin	—	0.1	—	0.1	—	0.1	—	0.1	—	0.1	—	0.05
Titanium	—	0.2	—	0.2	—	0.2	—	0.2	—	0.2	—	0.25 <sup>c</sup>
Chromium	—	—	—	—	—	0.6	—	0.6	—	—	<b>0.4</b>	<b>0.6</b>
Each other element <sup>e</sup>	—	0.05	—	0.05	—	0.10 <sup>d</sup>	—	0.10 <sup>d</sup>	—	0.10	—	0.05
Total other elements <sup>e</sup>	—	0.15	—	0.15	—	0.30	—	0.30	—	0.30	—	0.15

NOTE Specified impurities are shown in light type. Analysis is required to verify that the contents of the specified impurities are less than the limits given in this table. Analysis for other elements is made when their presence is suspected to be in excess of the “each other element” limit.

<sup>a</sup> LM28 and LM29 are also subject to metallographic structure requirements (see 5.4).

<sup>b</sup> LM31 castings in the “M” condition have to be naturally aged for 3 weeks before use, or before determination of mechanical properties.

<sup>c</sup> If titanium alone is used for grain refining, the amount present shall be not less than 0.05 %.

<sup>d</sup> Maximum cobalt content 0.5 %.

<sup>e</sup> In cases when alloys are required in the modified condition, the level of any modifying element present is not limited by the specified maximum value for other elements.

## 5 Specific requirements for castings

### 5.1 Chemical composition

The chemical composition of castings shall be as given in Table 1 to Table 3 for the appropriate alloy (see 6.2.2).

### 5.2 Condition

The castings shall be supplied in one of the following conditions, as specified by the purchaser (see item b) 3) Of appendix A) and cited in Table 4.

M	as cast
TS	stress relieved only
TE	precipitation treated
TB	solution treated and quenched
TB7	solution treated, quenched and stabilized
TF	solution treated, quenched and precipitation treated
TF7	solution treated, quenched and precipitation treated and stabilized.

If stress relieving treatment (TS) is required, details of the stress relieving procedure to be applied shall be stated on the order (see item b) 3) of appendix A).

### 5.3 Mechanical properties

**5.3.1 Tensile properties.** For castings the tensile properties, determined by the methods specified in 8.2 on samples taken in accordance with 7.1, shall be as given in Table 4.

NOTE The tensile property requirements are specified for separately cast test samples. They do not necessarily represent the properties obtainable from all parts, or in all directions, of a casting, which will depend on a number of factors including wall thickness and cooling characteristics.

**5.3.2 Hardness properties.** For castings in LM13, LM26, LM28 and LM29 the average value obtained for the Brinell hardness, determined by the methods specified in 8.3 on samples taken in accordance with 7.2, shall be as given in Table 5.

### 5.4 Microstructure of LM28 and LM29 castings

For each cast of LM28 and LM29 castings, a separately chill cast test sample as shown in Figure 1 shall be poured for metallographic examination. A transverse section taken from this test sample shall, when suitably prepared and examined microscopically, reveal an even distribution of primary silicon crystallites in the eutectic matrix. The average size of the crystallites shall not exceed 40  $\mu\text{m}$  and the maximum size for an individual particle shall not exceed 70  $\mu\text{m}$ .

### 5.5 Marking

Each batch of castings delivered shall be clearly labelled to indicate the manufacturer and the alloy designation.

### 5.6 Certificate

When requested (see item b) 4) of appendix A), the supplier shall certify that the castings comply with this standard.

## 6 Inspection procedures

### 6.1 General

The requirements for the testing of ingots and the minimum requirements for the testing of castings shall be as specified in 6.2.

NOTE The purchaser has the option to specify inspection and test procedures for castings supplementary to those specified in 6.2 (see appendix B). It is emphasized that over-inspection will lead to unnecessarily high costs and longer delivery times with no compensating advantages. For these reasons it is essential to select only those supplementary procedures that are necessary for the design and product concerned.

Retests shall be permitted as specified in 6.3.

### 6.2 Minimum inspection requirements

**6.2.1 Analysis of ingots.** Analysis samples shall be taken from the melt and analysed to represent each cast. The number of samples taken shall be as follows:

- for ingot casts of less than 1 t: one sample;
- for ingot casts of 1 t or more: a minimum of two samples, one taken at the beginning of the cast and the other taken at the end of the cast.

NOTE In all cases, the ingot maker should carry out sufficient analytical checking of the production to ensure conformity to the chemical composition requirements of the specification of the ingots.

**6.2.2 Analysis of castings.** No minimum requirements are specified for the rate of sampling for the analysis of castings.

NOTE The castings manufacturer should carry out sufficient analytical checking of the production to ensure conformity to the chemical composition requirements of the castings.

The sampling rate will depend, to a large extent, on the furnace charge make-up and may be less when the furnace charge consists wholly of analysed ingot and identified foundry returns than it would need to be if the furnace charge contained material of less reliable composition.

**6.2.3 Mechanical testing for castings.** For the determination of the tensile properties of castings, other than pressure die castings, the frequency of tensile testing shall be:

- for heat treated castings, at least one test for each heat treatment batch; or
- for other castings, the lesser of either one test per cast, or one test per alloy for each 500 kg of fettled castings.

Table 4 — Mechanical properties for castings (obtained on separately cast test samples<sup>a</sup>)

Designation	Condition	Tensile strength		Elongation on 5.65 $\sqrt{S_0}$	
		Sand or investment cast	Chill cast	Sand or investment cast	Chill cast
		min.	min.	min.	min.
<i>Group A alloys</i>		N/mm <sup>2</sup>	N/mm <sup>2</sup>	%	%
LM2	M	—	150	—	—
LM4	M	140	160	2	2
	TF	230	280	—	—
LM6	M	160	190	5	7
LM20	M	—	190	—	5
LM24	M	—	180	—	1.5
LM25	M	130	160	2	3
	TE	150	190	1	2
	TB7 <sup>b</sup>	160	230	2.5	5
	TF	230	280	—	2
LM27	M	140	160	1	2
<i>Group B alloys</i>					
LM0	M	—	—	—	—
LM5	M	140	170	3	5
LM9	M	—	190	—	3
	TE	170	230	1.5	2
	TF	240	295	—	—
LM13 <sup>c</sup>	TE	—	210	—	—
	TF	170	280	—	—
	TF7	140	200	—	—
LM16	TB	170	230	2	3
	TF	230	280	—	—
LM21	M	150	170	1	1
LM22	TB	—	245	—	8
<i>Group C alloys</i>					
LM12	M	—	170	—	—
LM26 <sup>c</sup>	TE	—	210	—	—
LM28 <sup>cd</sup>	TE	—	170	—	—
	TF	120	190	—	—
LM29 <sup>cd</sup>	TE	120	190	—	—
	TF	120	190	—	—
LM30	M	—	150	—	—
	TS	—	160	—	—
LM31 <sup>e</sup>	M	215	—	4	—
	TE	215	—	4	—

<sup>a</sup> See note to 5.3.1.

<sup>b</sup> After solution treatment, castings have to be heated at a temperature and for a time that will ensure reasonable stability of the mechanical properties.

<sup>c</sup> LM13, LM26, LM28 and LM29 are subject also to hardness requirements (see 5.3.2 and Table 5).

<sup>d</sup> LM28 and LM29 are subject also to microstructure requirements (see 5.4).

<sup>e</sup> LM31 castings in the "M" condition have to be naturally aged for 3 weeks before use, or before determination of mechanical properties.

For the determination of hardness (applicable to LM13, LM26, LM28 and LM29 only) at least one test shall be made to represent each cast, or each heat treatment batch, whichever is the smaller.

NOTE For pressure die castings, the rate of sampling for mechanical testing should be agreed between the purchaser and the supplier (see item b) 5) of appendix A).

### 6.3 Retests

**6.3.1 General.** Retests for analysis and tensile test results shall be permitted as specified in **6.3.2** and **6.3.3**.

NOTE No requirements for retests are specified in respect of microstructure (LM28 and LM29 castings), or hardness (LM13, LM26, LM28 and LM29 castings). Actions to be taken in the event that the initial samples fail to meet these requirements should be agreed between the purchaser and the supplier (see item b) 6) of appendix A).

**Table 5 — Hardness of castings**

Designation	Condition	Brinell hardness	
		min.	max.
LM13	TE	90	130
	TF	100	150
	TF7	65	90
LM26	TE	90	120
LM28	TE	90	130
	TF	100	140
LM29	TE	100	140
	TF	100	140

**6.3.2 Analysis.** If analysis shows results outside the specification limits (see Table 1 to Table 3), a further portion of the same sample, or of a new sample, shall be permitted to be taken for check analysis. If the check analysis is found to comply with the chemical composition requirements, the ingots or castings represented shall be deemed to comply with this standard. If the check analysis shows results which confirm the original analysis, the ingots or castings represented shall be deemed not to comply with this standard.

**6.3.3 Tensile test.** If a test piece fails the tensile test (see **8.2**), two further pieces taken at the same time and from the same cast shall be permitted to be tested. If one of the further test pieces meets the tensile requirements, then the batch of castings represented shall be deemed to comply with this standard. If both of the further test pieces fail then the batch of castings represented shall be deemed not to comply with this standard.

NOTE If the failed test piece represents a batch of heat treated castings, the supplier has the option to heat treat further the whole batch and resubmit the batch for all the tests called for on the order.

## 7 Test samples

### 7.1 Samples for tensile tests

**7.1.1 General.** The test sample shall be of a suitable size for producing a test piece to the dimensions of one of the proportional round test pieces given in BS 18.

Tensile test samples, taken at the sampling rate given in **6.2.3**, shall be separately poured at the same time, and from the same metal, as the castings they represent. For castings subject to heat treatment, the tensile test samples shall be heat treated with the castings they represent.

NOTE For heat treatment control purposes, bars of the same alloy and similar composition may be used if related test bars are no longer available, provided that the original tests with the related test bars had complied with this standard.

The test samples shall be cast to the appropriate shape selected from Figure 1 to Figure 6 in accordance with **7.1.2**, **7.1.3** or **7.1.4**.

**7.1.2 Sand castings.** The test samples shall be cast in sand moulds which have internal dimensions as shown in Figure 1 (form A or form B), Figure 3 (form E) or Figure 4 (form F). For forms A and B the mould design shall be such that the portion of the sample from which the test piece is to be machined shall be separated from the walls of the container by not less than 27 mm of sand.

**7.1.3 Chill castings.** The test samples shall be cast in metal chill moulds having the internal dimensions shown in Figure 1 (form A or form B) or Figure 2 (form C or form D).

**7.1.4 Investment castings.** The test samples shall be cast in moulds of a similar material, under similar conditions to those of the castings represented. The moulds used shall have the dimensions given in Figure 5 (form G, a “cast-to-size” test piece) or Figure 6 (form H).

### 7.2 Samples for hardness tests (applicable to castings in alloys LM13, LM26, LM28 and LM29)

Whenever possible, hardness tests shall be performed on the actual castings. When this is not possible, the tests shall be performed on separately cast samples, e.g. the grip ends of the tensile test samples before the tensile test is carried out. At least one test shall be made to represent each cast.

### 7.3 Samples for microstructure tests (applicable to castings in alloys LM28 and LM29)

Microstructure tests shall be performed on separately chill cast test samples, as shown in Figure 1 (see also **5.4**).

## 8 Test methods

### 8.1 General

The test samples and test pieces shall not be worked or heat treated before testing, except in the case of test samples that are heat treated with the castings they represent.

### 8.2 Tensile test

From the test samples of forms A, B, C, D, E, F and H taken in accordance with 7.1, tensile test pieces shall be machined to the dimensions of one of the proportional round test pieces given in BS 18. Test samples of form G are "cast to size" and shall not be machined before testing.

The tensile tests shall be carried out in accordance with BS 18.

### 8.3 Hardness test

Brinell hardness tests shall be carried out in accordance with BS 240, on a suitable surface of the castings, or on a separately cast sample (see 7.2).

NOTE Whenever possible the tests should be carried out using a ball of 10 mm diameter and a test force of 9.807 kN. Where this combination is not suitable, an alternative, preserving the same  $F/D^2$  ratio should be used.

The test shall consist of three hardness determinations on each sample tested and the average of the three hardness numbers shall be taken as the hardness for the sample.

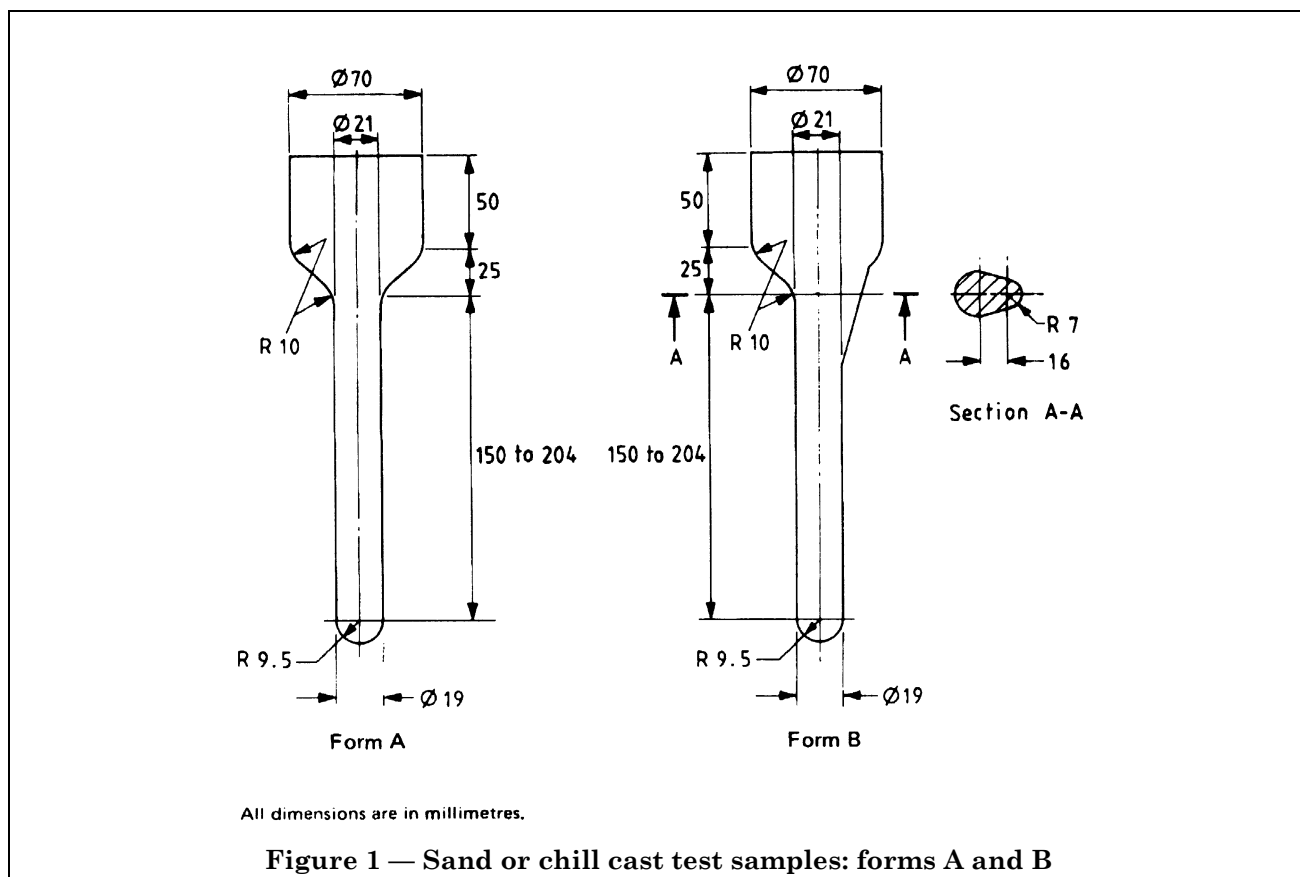

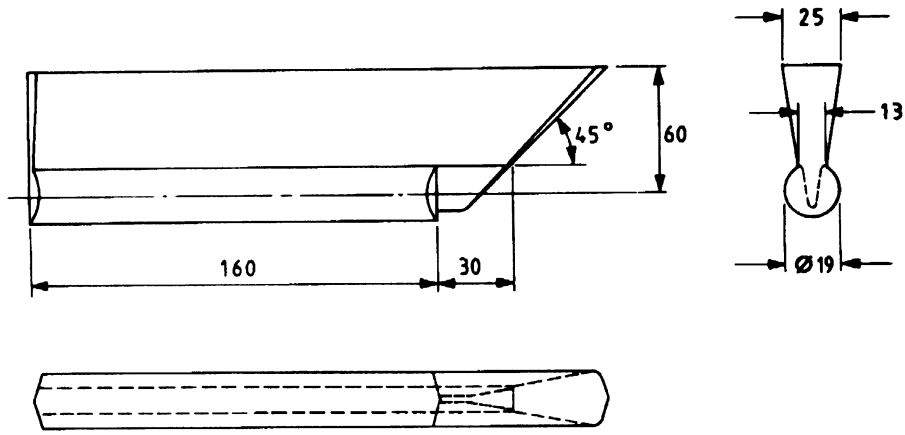

Form C

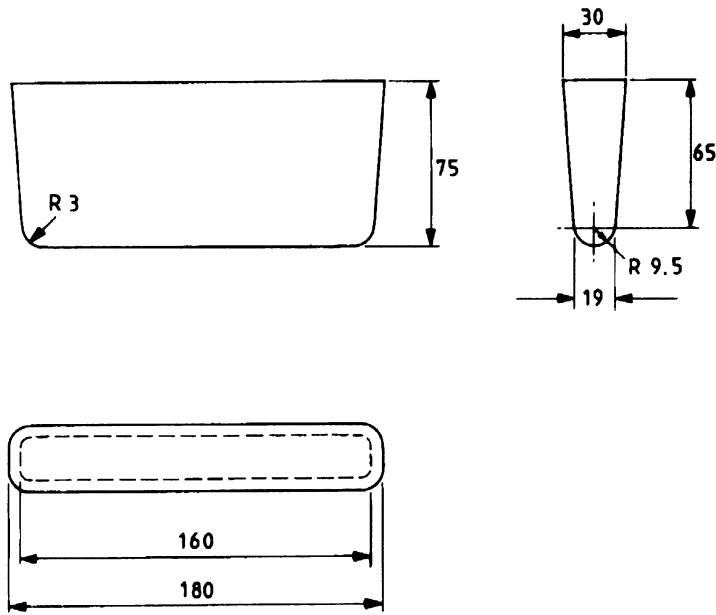



Form D

All dimensions are in millimetres.

Figure 2 — Chill cast test samples: forms C and D

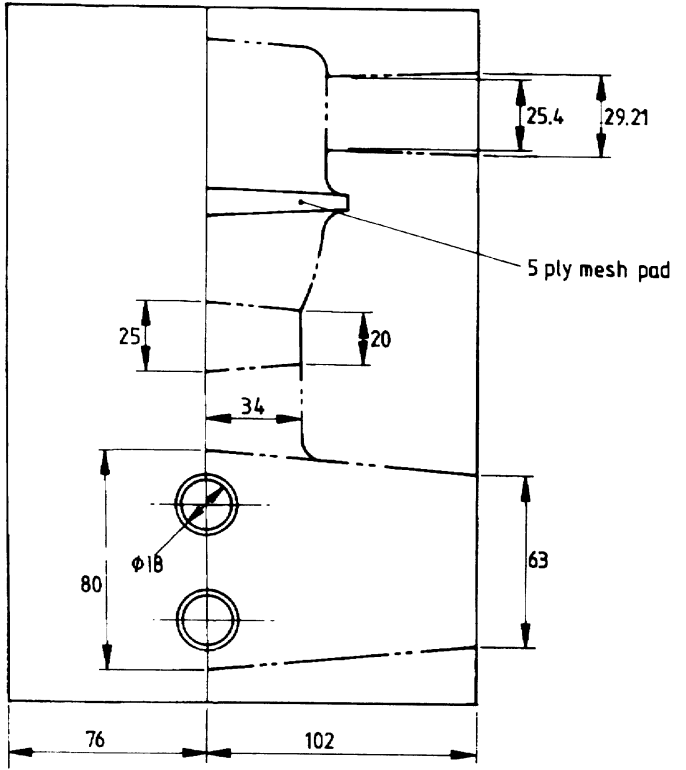
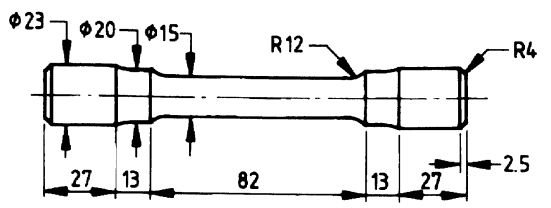
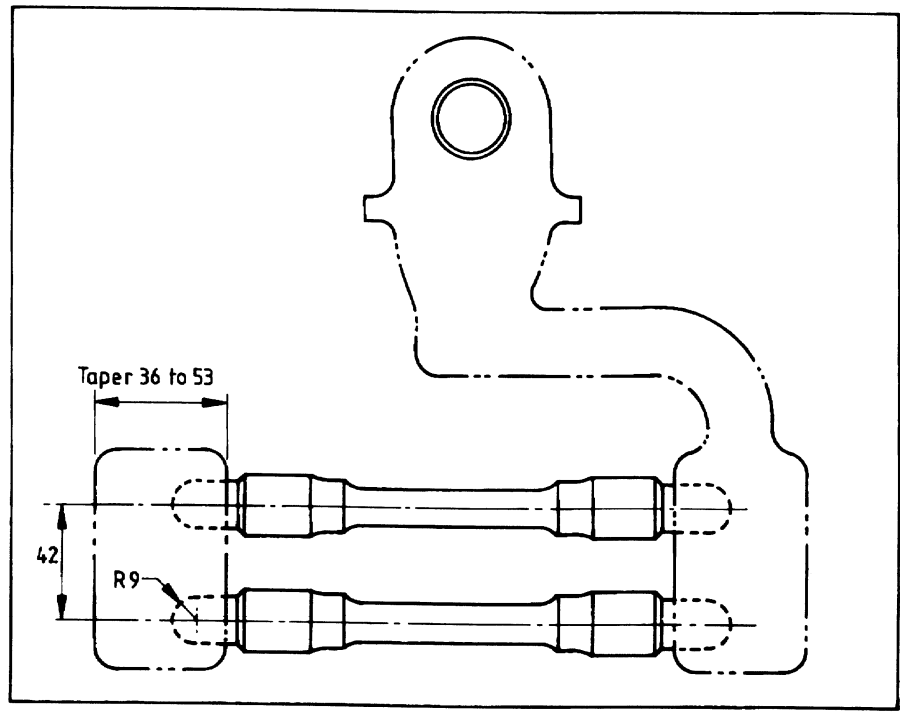

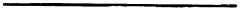

Casting and core profile shown thus   
Feeder system shown thus 

All dimensions are in millimetres.

Figure 4 — Sand cast test sample: form F



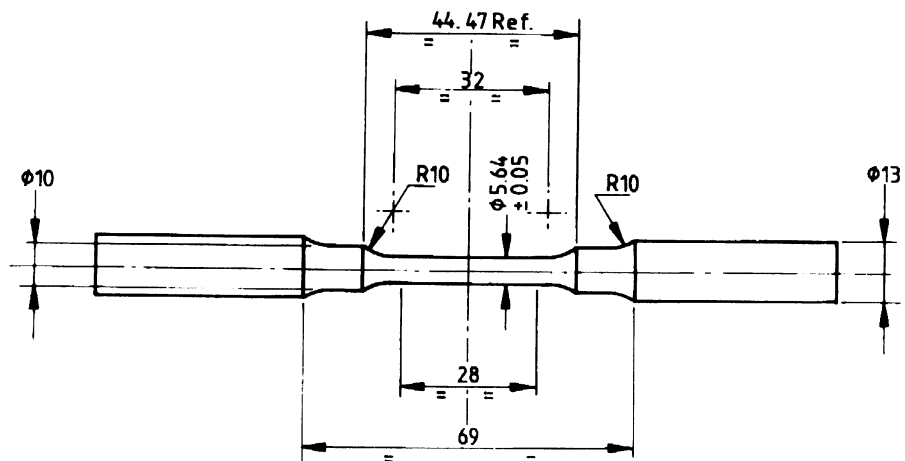
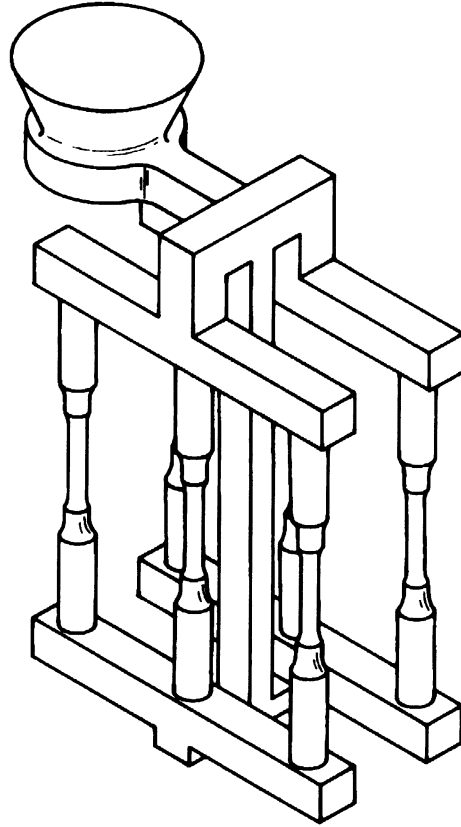

All dimensions are in millimetres.

NOTE Unless otherwise shown, the general tolerance is  $\pm 0.25$

Figure 5 — Investment cast test sample: form G (“cast to size”)

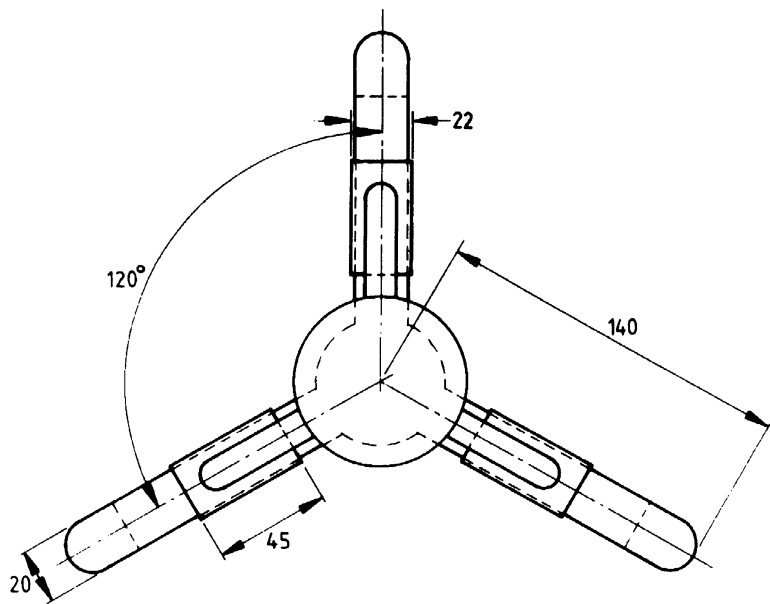
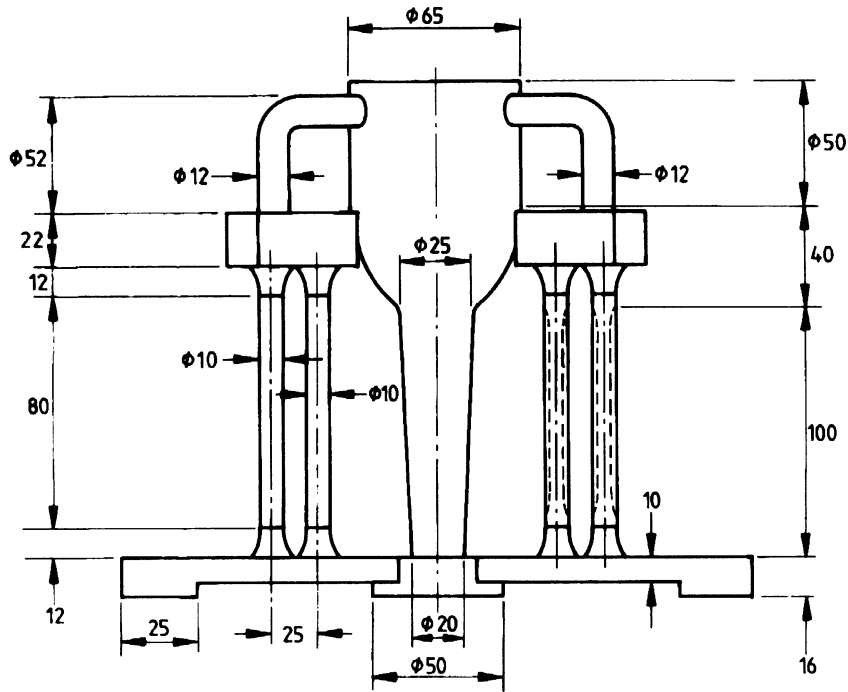

All dimensions are in millimetres.

Figure 6 — Investment cast test sample: form H

## Appendix A Information to be supplied by the purchaser

It is essential that the following information be given by the purchaser in the enquiry and order to assist the supplier in providing the correct ingots or castings.

- a) For ingots:
  - 1) the material designation (see Table 1, Table 2 and Table 3);
  - 2) details of any special requirements;
  - 3) details of any acceptance levels concerning permissible defects in the ingots.
- b) For castings:
  - 1) the material designation (see Table 1, Table 2 and Table 3);
  - 2) the casting process to be used (see note 1 to clause 1);
  - 3) the condition of the castings to be supplied (see 5.2 and Table 4) and the details of the stress relieving treatment if castings in the TS condition are ordered;
  - 4) whether a certificate of compliance with this standard is required (see 5.6);
  - 5) for pressure die castings, the rate of sampling for mechanical testing (see 6.2.3);
  - 6) retesting requirements in respect of microstructure (LM28 and LM29 castings), or hardness (LM13, LM26, LM28 and LM29 castings) (see 6.3.1);
  - 7) details of any acceptance levels concerning permissible defects in the castings;
  - 8) a fully detailed and fully dimensioned drawing of the casting(s) required, giving the part and pattern numbers, and including, as appropriate, casting datum points, critical dimensions, jig locations, machining allowances and machining pick up points;
  - 9) details of the actual pattern equipment if this is to be supplied by the purchaser;
  - 10) the quantity, or schedule, of castings required;
  - 11) whether the castings are to be supplied to any of the optional supplementary inspection and test requirements (see note to 6.1 and appendix B) and if so, full details of the test schedule for the castings (see B.8).

## Appendix B Recommendations for optional supplementary inspection and tests for castings

### B.0 Introduction

This appendix gives recommendations for inspection and tests for castings, additional to those requirements in the main body of the standard, which may be considered by the purchaser to be appropriate for castings for certain applications, such as those involving highly stressed or high pressure systems.

### B.1 General

It is essential that all castings to this standard comply with the general requirements of clause 3.

This appendix describes additional optional quality control and inspection requirements for castings, some or all of which may be specified by a purchaser at the time of the enquiry and order and defined in a test schedule (see item b) 11) of appendix A).

Where any of the options given in this appendix are called up in the test schedule, the castings should comply with the options, in addition to those in clause 3 of the standard.

The degree and frequency of testing shown in clause 3 is adequate for castings for most general applications and the majority of castings will not require further testing.

NOTE 1 Attention is drawn to the comments in the note to 6.1 of this standard.

NOTE 2 When castings are ordered to this standard without specifying any of the options described in this appendix, then the inspection control exercised by the supplier is entirely at his discretion, provided that he complies with the requirements of the standard.

NOTE 3 It is most desirable that there should be the earliest possible consultation between the purchaser, particularly when he is the designer, and the supplier or manufacturer: early agreement should be reached on such matters as choice of alloy for a given application. The information given on the primary characteristics of the alloys listed in Table 1 to Table 4 will provide an initial guide in this matter. Agreement should also be reached on the effects of methods of production and finish, with an agreed choice of the most effective and least expensive method of inspection, appropriate to each pattern of castings.

Apart from the choice of alloy, consultation may lead to an agreed modification of the item to make it cheaper to produce both as a casting by the manufacturer and as a finished part by the purchaser. For example, for castings to be jig machined, agreement between the manufacturer and the purchaser on the location points for jiggling and on reference points for marking out for dimensional inspection is desirable prior to commencement of production.

## B.2 Optional test procedures for castings

The aim of these recommendations for the inspection of castings is to provide castings of an assured quality to satisfy service requirements. It is expected that castings which are to be subjected to special or arduous service requirements, where a failure could have disastrous effects, will be subject to additional inspection and/or test requirements over and above the normal requirements for castings for general use.

The following optional supplementary inspection and test procedures for castings are available (see item b) 11) of appendix A):

- a) analysis: code A (see **B.3**);
- b) cut-up tensile testing: code T (see **B.4**);
- c) hardness testing: code H (see **B.5**);
- d) pressure testing: code P (see **B.6**);
- e) penetrant flaw detection: code F (see **B.7**);
- f) radiographic examination: code R (see **B.7**).

Examples of optional supplementary inspection and test procedures, with appropriate codings, for typical applications are as follows:

- 1) castings requiring pressure testing: code P;
- 2) pressure-tight castings where corrosion resistance is critical requiring analysis and pressure testing: code AP;
- 3) castings subject to high stresses and severely corrosive conditions, analysis, cut-up tensile testing and flaw detection: code ATF;
- 4) castings for highly critical stressed conditions, requiring analysis, cut-up tensile tests, hardness test and radiography: code ATHR.

## B.3 Analysis: code A

When castings are ordered to code A, take a minimum of one test sample to represent each cast poured.

For castings made wholly from approved ingots, analyse two of the test samples to represent each batch of ingots melted, one from the beginning and one from the end of the ingot batch.

For castings made wholly from a mixture of approved ingot and approved scrap, analyse a minimum of one of the test samples for each 500 kg, or fraction thereof, of fettled castings.

For castings made wholly or partly from non-approved ingot, scrap or other material, analyse test samples as follows:

- a) for non-continuous melting, analyse one sample per cast of less than 1 t and two samples, one taken at the beginning of the cast and the other taken at the end of the cast, for casts of more than 1 t;

- b) for continuous melting, analyse a minimum of one test sample for each 250 kg, or fraction thereof, of fettled castings.

## B.4 Cut-up tensile testing: code T

In addition to the tensile testing requirements on separately cast test bars given in **5.3.1**, castings may also be supplied subject to cut-up testing: code T. When code T is ordered carry out tensile tests on samples either:

- a) cut from the casting; or
- b) cast integrally with the casting.

The location of the sample, the test piece size, the frequency of testing and the minimum requirements for tensile properties are to be agreed between the manufacturer and the purchaser and included in the test schedule for the casting.

**NOTE** It should be noted that the mechanical properties of castings depend on the complexity of the casting and section thicknesses. Therefore the minimum requirements given in Table 4 may not be achieved with cut-up or integrally cast specimens. The Table 4 values should not be specified, therefore, for this type of specimen.

## B.5 Hardness testing: code H

In addition to the hardness test requirements applicable to LM 13, LM26, LM28 and LM29 specified in this standard, hardness test requirements for castings in other alloys may be agreed between the purchaser and the manufacturer and specified in the order/drawing: code H. The agreed minimum and/or maximum hardness test values should be given in the test schedule, together with details of the method of test, particularly the location, the size of the indenter and the load to be used.

## B.6 Pressure testing: code P

When required by the purchaser, and specified in the order/drawing and test schedule, castings may be subject to pressure testing: code P. Full details of the test method, including the test medium, temperature, pressure, time under test and the proportion of castings (if less than 100 %) to be tested should be agreed between the purchaser and the manufacturer and stated in the test schedule.

When code P castings are ordered, the castings are not permitted to be impregnated or otherwise treated by a process designed to improve pressure tightness.

**B.7 Inspection for defects: codes F and R****B.7.1 Penetrant flaw detection: code F**

When required by the purchaser and specified in the order/drawing and test schedule, castings may be subject to a penetrant flaw detection. Full details of the test method, the proportion of castings to be tested (if less than 100 %) and the standards of acceptance should be agreed between the purchaser and the manufacturer and stated in the test schedule.

**B.7.2 Radiographic examination: code R**

When required by the purchaser and specified in the order/drawing and test schedule, castings may be subject to a radiographic inspection. Full details of the technique to be used, the proportion of castings to be tested (if less than 100 %) and the standards of acceptance should be agreed between the purchaser and the manufacturer and stated in the test schedule.

**B.7.3 Rectification of defects**

For code F and code R castings the manufacturer is generally permitted to rectify any defects found in a casting either a) by complete removal of the imperfection and blending the contour smoothly to that of the remainder of the casting, provided this can be accomplished within the permitted dimensional tolerances, or b) by weld repairing followed by re-heat treatment to the specification.

If the purchaser will not permit the manufacturer to rectify defects in these castings by either of these techniques, this should be made clear in the order and test schedule.

For code R castings which have been weld repaired, the integrity of the weld should be verified by both radiography and penetrant inspection.

**B.8 Information to be included in the purchaser's test schedule**

It is recommended that provision should be made for the following minimum information to be included in the test schedule.

*General*

Component description

Drawing numbers

Alloy designation

Inspection coding

Pattern numbers

*Analysis*

Whether code A (analysis) is applicable

*Mechanical testing*

Whether code T (cut-up tensile testing) is applicable  
Whether samples are to be cut from the casting, or cast integrally with the casting

Location of sample

Size of test piece for tensile test

Frequency of sampling/testing

Minimum tensile properties required

*Hardness testing*

Whether code H (hardness testing) is applicable, on castings in alloys other than LM 13, LM26, LM28 or LM29  
The maximum and/or minimum hardness required  
The method of test, size of indenter and load  
Location of the test area on the casting

*Pressure testing*

Whether code P (pressure testing) is applicable

Type of test

Test pressure, working pressure and test medium

Special test requirements, i.e. time, temperature, etc.

Proportion of castings to be tested if less than 100 %

*Penetrant flaw detection*

Whether code F (penetrant flaw detection) is applicable  
Type of test, and criteria for acceptance  
Areas of the casting to be subject to testing  
Whether testing is to be carried out before or after machining  
Proportion of castings to be tested if less than 100 %

*Radiography*

Whether code R (radiography) is applicable  
Proportion of castings to be radiographed if less than 100 %  
Details of the technique to be used  
Areas of the casting to be subject to testing  
The system of radiograph approval

**B.9 Marking**

Castings subject to optional supplementary inspection and test requirements should be either individually marked, or batched and tallied by a suitable means, as soon as possible after casting. The identification should be maintained in such a manner as to enable the castings to be correlated with their relevant inspection records, such records to be retained and made available to the purchaser on request.

**B.10 Certificates**

For castings subject to optional supplementary inspection and tests the manufacturer should certify that the castings comply with this standard and the test schedule and include the cast identity and the results of all tests called for in the test schedule.

## Appendix C Colour code for ingots

Table 6 gives the colour coding to be used to identify ingots to this standard.

**Table 6 — Colour code for ingots**

Ingot alloy designation	Colour code
LM 0	White
LM 2	Red and white
LM 4	Red
LM 5	Black
LM 6	Yellow
LM 9	Yellow and brown
LM 12	Green
LM13	Yellow and black
LM 16	Red and black
LM20	Yellow and green
LM21	Red and green
LM22	Red and brown
LM24	Red and blue
LM25	Yellow and blue
LM26	Brown and blue
LM27	Green and blue
LM28	Brown and white
LM29	Brown and green
LM30	Green and black
LM31	Blue and white

The colours used are those standardized in BS 381C, as follows:

Yellow	309	Blue	166
Red	537	Green	218
Black	—	Brown	414
White	—		

## Appendix D Guide to the selection of alloys

### D.0 Introduction

In this British Standard the alloys are classified into three groups namely general purpose alloys, special purpose alloys and special purpose alloys of limited application. The object of this appendix is to assist the end-user of aluminium alloy castings to choose the most appropriate alloy for the application. This appendix has therefore been written with two approaches, one to describe the characteristics of each alloy and the other to examine particular applications and suggest which alloys may be used. To some extent the choice of alloy is determined by the casting process to be used, which in turn is governed by the number of castings required and the need for them to have particular characteristics such as dimensional accuracy and good as-cast surface finish.

### D.1 General purpose alloys

#### D.1.1 General

The majority of aluminium castings are produced in the general purpose alloys LM2, LM4, LM6, LM20, LM24, LM25 and LM27. This group of alloys should be considered first, to see whether an alloy from this group offers the particular properties or characteristics required for the application. All of the alloys in this group have good foundry characteristics and are therefore unlikely to give rise to serious casting difficulties. There are economic benefits to the user to select these alloys if they satisfy the requirements of the application, since castings in these alloys will be available from a wide range of manufacturers.

#### D.1.2 Sand, gravity die and investment castings: LM4, LM6, LM25 and LM27

**D.1.2.1 LM4.** This is a very widely used and versatile alloy. It is suitable for an almost unlimited range of castings for general engineering application, domestic and office equipment, household fittings, electrical tools and switchgear, automobile engine and transmission components and most uses requiring moderate mechanical properties.

Its foundry characteristics permit its use by all the casting processes for thin or thick sections and also for castings required to be pressure tight. It is also available in the fully heat-treated condition for castings required to sustain relatively high static loads. The response of this alloy to heat treatment is dependent on the presence of magnesium and it is therefore important, if the castings are to be subsequently heat treated, that the magnesium content should be near to the top end of the range (0.20 % maximum). On the other hand if the castings are to be used in the as-cast condition then the magnesium content should be at the low end of the range and preferably less than 0.1 %.

**D.1.2.2 LM6.** The essential characteristic of LM6 is its excellent castability, which permits the production of castings of intricate shape and very thin and varying wall thickness. Such castings may be produced with little danger of hot tearing or cracking. For thick section castings and for sand and investment castings it is usual to improve the mechanical properties by modifying the eutectic structure by adding sodium or strontium.

Its suitability for particular applications depends partly on its castability and partly on its high resistance to corrosion. It is used, for example, for "on deck" castings and other marine applications; for water-cooled manifolds and jackets; thin walled and intricate instrument cases, switch boxes and motor housings; very large castings such as doors and panels; pumps and other equipment in the chemical and dye industries; castings used in the manufacture of paint and food and for a wide range of domestic tools and kitchen equipment.

For castings forming part of a welded assembly LM6 is the most suitable alloy.

**D.1.2.3 LM25.** Where castings are to have high levels of tensile strength with reasonable ductility, LM25 in the fully heat treated condition will satisfy the majority of requirements. It has the added advantage of good resistance to corrosion. It is used for a wide range of engineering equipment and its many applications in road transport vehicles include engine cylinder blocks, heads and wheels.

It is also used in the food and chemical industries where advantage can be taken of its good corrosion resistance. The range of uses is extended by the availability of the alloy in the as-cast and partially heat treated conditions as well as the fully heat treated condition and the alloy is used where the application demands better mechanical properties and machinability than is offered by LM6. The response to heat treatment is dependent on the magnesium content and this should be controlled carefully, bearing in mind that magnesium can be lost when molten metal is held for long periods of time and/or at elevated temperature.

For optimum tensile strength the low end of the magnesium range should be avoided. Most investment castings in aluminium alloys are produced in LM25 alloy, or in the wide variety of alloys of very similar compositions that exist in aerospace and foreign specifications. The applications include radar and electronic housings, often with cast heat sinks and slots for printed circuit boards, thus simplifying servicing and reducing assembly costs.

**D.1.2.4 LM27.** This alloy is similar to LM4 and LM21 in its mechanical properties and foundry characteristics it is suitable, therefore, for the applications for which LM4 has already been recommended. Although the alloy is only standardized in the as-cast condition it does respond to heat treatment. As with LM4 the response to heat treatment is dependent on the presence of magnesium and it is therefore important if the castings are to be subsequently heat treated that the magnesium content should be near to the top end of the range (0.35 % maximum). If the castings are to be used in the as-cast condition then the magnesium content should be at the low end of the range and preferably less than 0.1 %.

### **D.1.3 Pressure die castings: LM2, LM6, LM20 and LM24**

**D.1.3.1 LM2.** Most pressure die castings are made in either LM2 or LM24 and for most applications the two alloys are interchangeable. Users may wish to note, however, that LM2 has a slightly lower specific gravity than LM24 and when dealing with many thousands of castings the difference may become significant. LM2 is essentially a pressure die casting alloy with excellent casting characteristics and the castings have a higher tensile strength and better machinability than pressure die castings made in either LM6 or LM20. Where the casting is to be used in a corrosive environment then the use of LM2 would not be recommended unless protection of the casting by a process such as anodizing is used. It is better in such circumstances to consider the use of either LM6 or LM20.

**D.1.3.2 LM6.** This alloy is recommended for those pressure die castings for which the service operating conditions require a resistance to corrosion higher than that generally offered by LM2 and LM24. For applications involving contact with chemicals, foodstuffs, sea water and marine conditions and those demanding the highest resistance to corrosive atmospheres, LM6 is the most suitable alloy.

The outstanding fluidity and freedom from hot-tearing of LM6 facilitates the production of some complex castings of large surface area and thin walls (in certain die casting machines), although in other respects LM2 and LM24 are better pressure die casting alloys.

**D.1.3.3 LM20.** The applications of this alloy are similar to those of LM6, except that the alloy has a corrosion resistance that is not quite as good as LM6. However, the alloy has a slightly better castability than LM6 and its higher iron content reduces the problem of molten metal/die interaction known as “welding-on”.

**D.1.3.4 LM24.** This alloy accounts for a greater tonnage of aluminium castings than any other alloy. It has excellent die casting characteristics and the castings have higher tensile strength and better machinability than pressure die castings made in either LM6 or LM20. Where the casting is to be used in a corrosive environment then the use of LM24 would not be recommended unless protection of the casting by a process such as anodizing is used. It is better in such circumstances to consider the use of either LM6 or LM20.

## D.2 Special purpose alloys

### D.2.1 General

Some applications for castings may demand special characteristics which are not provided by the alloys in the general purpose group. Where such characteristics are an essential requirement, selection of the most suitable alloy may be made from the group of alloys described below. It should be noted that many of these alloys present greater foundry problems or are more limited in the complexity of the castings which can be made, compared with the general purpose group. Furthermore, some alloys may only be readily obtainable from specialist manufacturers.

### D.2.2 Characteristics and types of application

**D.2.2.1 LM0.** This alloy has a high electrical conductivity. It is also suitable for food and chemical plant fittings because of its excellent corrosion resistance. The alloy can be anodized to give films that can be coloured. The castability is poor because of the high shrinkage on solidification and the alloy has poor resistance to hot tearing.

**D.2.2.2 LM5.** This alloy has high resistance to corrosive attack and is suitable for castings for marine, food processing and decorative applications. It is the most suitable alloy for decorative anodic finishing. Because of the high magnesium content of the alloy there is an increased tendency for oxide inclusions to be present in the castings and good foundry practice is essential.

**D.2.2.3 LM9.** This alloy is extensively used for low pressure castings and is suitable for applications where the fluidity and corrosion resistance of LM6 are required, combined with high strength and hardness as a result of heat treatment.

**D.2.2.4 LM13.** This alloy has good strength at elevated temperatures and low coefficient of expansion. It is used for pistons, mainly for internal combustion engines. Machining should be carried out with carbide-tipped or diamond tools.

**D.2.2.5 LM16.** This alloy has high strength and hardness in the fully heat-treated condition, which is maintained at temperatures up to 200 °C. It is used for pressure tight castings.

**D.2.2.6 LM21.** This alloy is specially suitable for castings required to have high proof stress and hardness combined with good machinability and castability, in the as-cast condition.

**D.2.2.7 LM22.** This alloy has high shock resistance and tensile strength. It is suitable for structural components and for castings for heavy duty service, such as in road transport vehicles.

## D.3 Special purpose alloys of limited application

### D.3.1 General

As with the alloys in the special purpose group, alloys in this group should only be considered for those applications where the particular properties of these alloys match the requirements. Because these alloys are produced in such small quantities, prospective users have to accept that the number of manufacturers able to offer castings in these alloys will be limited.

### D.3.2 Characteristics and types of application

**D.3.2.1 LM12.** This alloy is particularly suitable for castings for hydraulic equipment. The machinability is excellent and, if required, the alloy will respond to heat treatment, thus increasing its strength and hardness.

**D.3.2.2 LM26.** This alloy exhibits good elevated temperature strength and a low coefficient of expansion. It is therefore an alternative to LM 13 as a piston alloy. Machining should be carried out with carbide-tipped or diamond tools.

**D.3.2.3 LM28, LM29 and LM30.** These three alloys contain the highest amounts of silicon of any of the aluminium casting alloys in this standard and it is therefore essential for optimum properties that they are used in a condition in which the silicon phase has been refined with phosphorus. The alloys cast better if chill cast. The high silicon contents can give rise to problems of machinability and special machining techniques with diamond tools should be used. These alloys have good wear resistance and maintain their strength well at elevated temperatures. The alloys are therefore used for applications such as engine components.



**D.3.2.4 LM31.** This alloy is generally sand cast, but castings can also be produced using gravity and high pressure die casting techniques. It has the advantage that good strength and toughness can be developed merely by natural ageing, or by elevated temperature ageing after casting. The risks of distortion or cracking on quenching after solution heat-treatment are therefore avoided. The alloy has good corrosion resistance and can be clear or colour anodized. It is used for general engineering castings and particularly for large sand castings.

#### D.4 Alloy selection by application

##### D.4.1 General principles

The designer sometimes needs to design a casting for which there are certain conditions that are of overriding importance, for example if the casting is to be used in a marine environment. In this case, whatever mechanical properties may be required, or casting process used, the designer has to restrict his alloy selection to those alloys with the best corrosion resistance. Alternatively, the casting may need to be colour anodized for decorative effect and the alloy selection would need to be confined to those alloys responding to colour anodizing.

Guidance on the alloys that should be considered when certain requirements such as corrosion resistance, elevated temperature mechanical properties, machinability, etc. are important, is given in D.4.2 to D.4.8. It should not be assumed, however, that these guidelines will apply to every application and, where there is some doubt, more detailed information from the manufacturer should be sought.

##### D.4.2 Corrosion resistance

In the majority of applications where cast aluminium alloys are used, the environment is a normal atmosphere. All of the general purpose alloys are satisfactory for use in normal atmospheres and it has been shown by atmospheric corrosion tests that the severity of attack is as much influenced by the position of the site, as by the choice of a particular alloy. Atmospheric attack does not significantly reduce the strength of the casting, though in some cases the appearance may be impaired. In such cases extra protection by painting, enamelling or anodizing can be used. These coatings can also serve for decorative purposes, except that in most cases anodic films on cast alloys are of a dark grey colour.

Under more stringent conditions than normal atmospheres, such as in food processing plant, those alloys containing copper in excess of 0.4 % should be avoided and alloys LM5, LM6, LM9, LM20, LM25 and LM31 should be considered. These alloys can be anodized for extra protection and alloy LM5 is particularly suitable for bright anodizing. Where anodizing for decorative purposes is to be used, a very high standard of surface finish is required, and flow marks, variable grain size, surface crevices, etc. have to be reduced to an absolute minimum. Surface defects masked by polishing tend to reappear during anodizing. Matt finishes produced by grit or shot blasting provide a good basis for subsequent painting for which a suitable primer, such as zinc chromate should be used. Alloy LM0 has the best corrosion resistance of all the aluminium alloys, but the poor foundry characteristics and low mechanical properties rule out this alloy for all but a few special applications.

##### D.4.3 Machinability

If the machining conditions are selected to suit the characteristics of the various alloys, the majority can be machined faster and easier than many other materials. Machinability itself is a composite of many properties but it is possible to classify the alloys according to the ease with which small, regular chips can be produced on machining, with a minimum of tool wear.

An attempt at such a classification is given in Table 7. The addition of copper improves the machinability of the alloys. The high silicon alloys such as LM6 can be machined to a good finish if care is exercised in the machining conditions, and it is usual to use either carbide-tipped or diamond tools.

**Table 7 — Machinability ratings of aluminium casting alloys**

Rating group	Alloys
Group 4	LM5, LM12
Group 3	LM4, LM16, LM21, LM22, LM24, LM25, LM26, LM27, LM31
Group 2	LM0, LM2, LM9, LM13
Group 1	LM6, LM20, LM28, LM29, LM30
NOTE Alloys in group 4 are easiest to machine, the machinability decreasing through to group 1.	

#### D.4.4 Weldability

If welding is an essential part of the total fabrication, alloys LM4, LM6 and LM27 should be considered first. Either gas or argon arc techniques may be employed, using 10 % silicon filler rod for welding LM6 and 5 % silicon rod for LM4 and LM27. For the copper-containing alloys, such as LM12, a 5 % copper filler rod should be used. For the magnesium-containing LM5 alloy, a 5 % magnesium rod is used. LM25 is readily welded using 5 % silicon alloy or alloy complying with British Standard 2 L 99 as filler metal. If heat treatment is to be performed, the filler rod should match the alloy composition and the heat treatment should be carried out after welding.

#### D.4.5 Mechanical properties

Of the four alloys commonly used for pressure die casting, LM2 and LM24 have higher strengths than LM6 or LM20, although LM6 has a better ductility. This British Standard gives no requirements for the mechanical properties of pressure die castings, largely because of the difficulty of obtaining a separately cast pressure die cast test piece.

While the compositions of LM2 and LM24 would respond to heat treatment, these alloys are not solution heat treated because of the probability of blistering, if such castings were subjected to the high temperature necessary.

A much wider range of properties is available for sand, gravity and investment castings, because many of the alloys used respond to heat treatment. Alloy LM6 has good ductility and shock resistance, but its proof strength is low. If greater proof strength with high ductility is required, then LM22 can be used in the solution heat treated condition.

For highly stressed castings, fully heat treated LM4 or LM25 should be considered, and heat treated gravity die castings may be preferred to pressure die castings.

Some applications involve the use of cast aluminium components at elevated temperatures. For temperatures up to about 250 °C, alloys LM2, LM4, LM24 and LM27 can be used, as they retain a high proportion of their room temperature strength properties at these temperatures.

For temperatures in excess of 250 °C, LM13 or LM26 are useful and these alloys are widely employed for petrol and diesel engine pistons. Of the two alloys, LM13 is much more widely used, mainly in the stabilized condition.

Alloys LM28, LM29 and LM30 are also used at elevated temperatures, these alloys having a better wear resistance, because of their higher silicon content.

The creep rate for a given combination of stress and temperature should be taken into account when considering elevated temperature properties.

The fatigue endurance limits for  $5 \times 10^7$  cycles for most alloys are in the range 70 N/mm<sup>2</sup> to 100 N/mm<sup>2</sup>. Many fatigue failures can be traced to such factors as poor design or poor surface finish, rather than to the inherent fatigue characteristics of the alloy.

#### D.4.6 Wear resistance

Wear resistance is a very complex characteristic, the mechanism of wear being dependent on the actual conditions encountered. Often the wear found in practice is aluminium against steel and in unlubricated conditions two different wear mechanisms operate.

At low loads, wear is by progressive oxidation and spalling of the surface oxide. This oxidative wear rate is independent of the silicon content. At higher loads, metallic wear occurs on a massive scale by plastic deformation and fracture of the metal surface. The transition from oxidative to metallic wear occurs at higher loads as the silicon content increases.

The wear rate under sliding conditions has been found to decrease linearly with an increase in silicon content, from the eutectic composition up to 25 % silicon.

Therefore in wear resistant applications the high silicon alloys such as LM13, LM26, LM28, LM29 and LM30 are chosen. Fortuitously the higher silicon alloys also have a lower coefficient of expansion, which makes these alloys ideal for applications such as engine components.

Further improvements in the wear characteristics of hypereutectic silicon alloys have been achieved by surface etching techniques, which remove part of the aluminium matrix leaving the primary silicon particles standing proud of the matrix.

#### D.4.7 Physical properties

Some applications for castings require optimum values of electrical and thermal conductivity. The alloy with the highest electrical conductivity is LM0, which has a conductivity of 57 % IACS (i.e. 33.1 MS/m), at 20 °C. This alloy is therefore widely used in cast rotors for electric motors even though it has poor casting characteristics. The alloy can be deformed after casting and this property can be used in such applications as cable clamps.

Where good casting characteristics and mechanical properties are required in conjunction with good electrical conductivity, then LM6 or LM25 alloys can be used, their conductivities being of the order of 37 % IACS at 20 °C.

Generally, alloys having a high electrical conductivity also have a high thermal conductivity. This property becomes important in those applications where heat has to be dissipated quickly, for which finned castings are often designed. The best thermal conductivity is obtained with LM0, but again an acceptable compromise between castability, mechanical properties and thermal conductivity is offered by LM6 or LM25 which have thermal conductivity values approximately 146 W/(m K).

#### **D.4.8 Summary**

Table 8 summarizes much of the information given in this appendix on alloy selection. The highest value or suitability is denoted by 4, the lowest by 1 and "n" indicates that it is not normally recommended in this form or condition.

Table 8 — Comparison of casting characteristics and other properties

Designation	Form of casting				Fluidity	Resistance to hot tearing	Pressure tightness	Machinability	Resistance to corrosion	Strength at room temperature	Strength at elevated temperature	Shock resistance	Electrical conductivity	Decorative anodizing
	Die casting													
	Sand	Gravity	Low pressure	Pressure										
<i>General purpose alloys, group A</i>														
LM2	3n	3n	3n	4	3	4	4	2	2	4	3 <sup>a</sup>	2	2	1
LM4	4	4	3	3n	3	3	4	3	2	2	3	2	2	1
LM6	4	4	4	3	4	4	4	1	4	2	1 <sup>a</sup>	4	3	1
LM20	4	4	4	4	4	4	4	1	3	4	1 <sup>a</sup>	2	3	1
LM24	2n	2n	2n	4	3	4	4	3	2	4	3 <sup>a</sup>	2	2	1
LM25	4	4	4	3n	3	4	4	3	4	4 <sup>b</sup>	3 <sup>b</sup>	2 <sup>b</sup>	2	1
LM27	4	4	3	3n	3	4	4	3	3	2	3	2	2	1
<i>Special purpose alloys, group B</i>														
LM0	2	2	2	2	2	2	2	2	4	—	—	—	4	4
LM5	2	2	2	2	2	2	1	4	4	2	2	2	2	4
LM9	3	3	4	n	3	4	3	2	3	3	3	2	2	1
LM13	3	3	3	n	3	4	2	2	3	3	4	2	2	1
LM16	3	3	3	n	3	3	3	3	3	4	3	2	2	1
LM21	3	3	3	n	3	3	3	3	2	3	3	2	2	1
LM22	3	3	3	n	3	3	3	3	2	3	3	4	2	1
<i>Special purpose alloys of limited application, group C</i>														
LM12	2	3	1	n	2	3	3	4	1	2	3	1	2	1
LM26	3	3	3	n	3	4	2	3	2	3	4	2	2	1
LM28	1	2	1	n	2	3	2	1	3	2	3	1	1	1
LM29	1	2	1	n	2	3	2	1	3	2	3	1	1	1
LM30	n	2	2	3	3	2	2	1	2	2	3	2	1	1
LM31	3	2	2	2	2	2	2	3	4	4	3	4	1	3
NOTE 1 The highest value or suitability is denoted by 4, the lowest by 1.														
NOTE 2 "n" indicates that the alloy is not normally recommended in this form of casting.														
<sup>a</sup> The use of die castings is usually restricted to only moderately elevated temperatures.														
<sup>b</sup> Fully heat treated.														

---

## Publications referred to

BS 18, *Method for tensile testing of metals (including aerospace materials)*.

BS 240, *Method for Brinell hardness test and for verification of Brinell hardness testing machines*.

BS 381C, *Specification for colours for identification, coding and special purposes*.

BS 1400, *Specification for copper alloy ingots and copper alloy and high conductivity copper castings<sup>1)</sup>*.

BS 1957, *Presentation of numerical values (fineness of expression; rounding of numbers)*.

British Standard 2L 99, *Specification for ingots and castings of aluminium-silicon-magnesium alloy (solution treated and precipitation treated) (Si7, Mg0.3)*.

ISO 3522, *Cast aluminium alloys — Chemical composition and mechanical properties*.

---

<sup>1)</sup> Referred to in the foreword only.

---

# BSI — British Standards Institution

BSI is the independent national body responsible for preparing British Standards. It presents the UK view on standards in Europe and at the international level. It is incorporated by Royal Charter.

## Revisions

British Standards are updated by amendment or revision. Users of British Standards should make sure that they possess the latest amendments or editions.

It is the constant aim of BSI to improve the quality of our products and services. We would be grateful if anyone finding an inaccuracy or ambiguity while using this British Standard would inform the Secretary of the technical committee responsible, the identity of which can be found on the inside front cover. Tel: 020 8996 9000. Fax: 020 8996 7400.

BSI offers members an individual updating service called PLUS which ensures that subscribers automatically receive the latest editions of standards.

## Buying standards

Orders for all BSI, international and foreign standards publications should be addressed to Customer Services. Tel: 020 8996 9001. Fax: 020 8996 7001.

In response to orders for international standards, it is BSI policy to supply the BSI implementation of those that have been published as British Standards, unless otherwise requested.

## Information on standards

BSI provides a wide range of information on national, European and international standards through its Library and its Technical Help to Exporters Service. Various BSI electronic information services are also available which give details on all its products and services. Contact the Information Centre. Tel: 020 8996 7111. Fax: 020 8996 7048.

Subscribing members of BSI are kept up to date with standards developments and receive substantial discounts on the purchase price of standards. For details of these and other benefits contact Membership Administration. Tel: 020 8996 7002. Fax: 020 8996 7001.

## Copyright

Copyright subsists in all BSI publications. BSI also holds the copyright, in the UK, of the publications of the international standardization bodies. Except as permitted under the Copyright, Designs and Patents Act 1988 no extract may be reproduced, stored in a retrieval system or transmitted in any form or by any means – electronic, photocopying, recording or otherwise – without prior written permission from BSI.

This does not preclude the free use, in the course of implementing the standard, of necessary details such as symbols, and size, type or grade designations. If these details are to be used for any other purpose than implementation then the prior written permission of BSI must be obtained.

If permission is granted, the terms may include royalty payments or a licensing agreement. Details and advice can be obtained from the Copyright Manager. Tel: 020 8996 7070.