



Testing concrete —

Part 101: Method of sampling fresh concrete on site

UDC 666.972.017:691.32:620.1

Committees responsible for this British Standard

This British Standard was published under the direction of the Cement, Gypsum, Aggregates and Quarry Products Standards Committee CAB/-. Its preparation was entrusted to Technical Committee CAB/4 upon which the following bodies were represented:

British Aggregate Construction Materials Industries
 British Precast Concrete Federation Ltd.
 British Ready Mixed Concrete Association
 Cement Admixtures Association
 Cement and Concrete Association
 Cement Makers' Federation
 Concrete Society Limited
 County Surveyor's Society
 Department of the Environment (PSA)
 Department of the Environment (Building Research Establishment)
 Department of the Environment (Transport and Road Research Laboratory)
 Department of Transport
 Electricity Supply Industry in England and Wales
 Federation of Civil Engineering Contractors
 Greater London Council
 Institute of Concrete Technology
 Institution of Civil Engineers
 Institution of Highway Engineers
 Institution of Municipal Engineers
 Institution of Structural Engineers
 Institution of Water Engineers and Scientists
 National Federation of Building Trades Employers
 Royal Institute of British Architects
 Royal Institution of Chartered Surveyors
 Sand and Gravel Association Limited
 Society of Chemical Industry

The following bodies were also represented in the drafting of the standard, through subcommittees and panels:

British Civil Engineering Test Equipment Manufacturers' Association
 Coopted members

This British Standard, having been prepared under the direction of the Cement, Gypsum, Aggregates and Quarry Products Standards Committee, was published under the authority of the Board of BSI and comes into effect on 31 May 1983

© BSI 12-1998

The following BSI references relate to the work on this standard:
 Committee reference CAB/4
 Draft for comment 81/12319 DC

ISBN 0 580 11921 1

Amendments issued since publication

Amd. No.	Date of issue	Comments
6091	July 1989	
6728	July 1991	Indicate by a sideline in the margin

Contents

	Page
Committees responsible	Inside front cover
Foreword	ii
<hr/>	
1 Scope	1
2 Definitions	1
3 Apparatus	1
4 Sampling procedure	2
5 Certificate of sampling	2
6 Determination of sampling error	2
<hr/>	
Appendix A Certificate of sampling	4
<hr/>	
Figure 1 — Scoop	1
<hr/>	
Table 1 — Quantities of concrete required	2
<hr/>	
Publications referred to	Inside back cover
<hr/>	

Foreword

This Part of this British Standard, prepared under the direction of the Cement, Gypsum, Aggregates and Quarry Products Standards Committee, is a revision of clause 2 of BS 1881-1:1970 which has been deleted by Amendment No. 1 to that standard.

This Part describes methods of sampling from concrete mixes of all workabilities, advice being included for the sampling of very high workability concrete including mixes produced by the use of superplasticizers. Sampling in accordance with this standard will comply with the proposed international standard ISO 2736-1¹⁾.

An alternative method of sampling is permitted for the measurement of slump of concrete delivered in a truck.

In such a case, the sample is obtained from the initial discharge of concrete from the truck. This alternative method given in BS 1881-102 is only permitted for the slump test as no data are available at the present time for its use for other methods of test given in this standard.

No guidance is given in this Part of this standard for the number of specimens required for testing. Information in this respect may be found in other standards, e.g. BS 5328.

A British Standard does not purport to include all the necessary provisions of a contract. Users of British Standards are responsible for their correct application.

Compliance with a British Standard does not of itself confer immunity from legal obligations.

Summary of pages

This document comprises a front cover, an inside front cover, pages i and ii, pages 1 to 4, an inside back cover and a back cover.

This standard has been updated (see copyright date) and may have had amendments incorporated. This will be indicated in the amendment table on the inside front cover.

¹⁾ In course of preparation.

1 Scope

This Part of this British Standard describes methods to be used on site for obtaining from a batch of fresh concrete representative samples of the quantity required for carrying out the tests and making test specimens in accordance with other Parts of this British Standard together with a procedure for determining sampling errors using cube compressive strength test results. The methods specified apply to concrete made with aggregate having a nominal maximum size of no more than 40 mm and are suitable for very low, low, medium and high workability concretes up to a workability represented by 150 mm nominal slump. (For mixing and sampling in the laboratory, see BS 1881-1:1970²⁾).

NOTE The titles of the publications referred to in this standard are listed on the inside back cover.

2 Definitions

For the purposes of this Part of this British Standard, the definitions given in BS 5328 apply together with the following.

2.1 batch

the quantity of concrete mixed in one cycle of operations of a batch mixer, or the quantity of concrete conveyed ready-mixed in a vehicle, or the quantity discharged during 1 min from a continuous mixer

2.2 sample

a quantity of concrete, consisting of a number of standard scoopfuls, taken from a batch of concrete whose properties are to be determined

2.3 standard scoopful

the quantity of concrete taken by a single operation of the scoop, approximately 5 kg mass of normal weight concrete

2.4 sampling error

the random error arising from inevitable deficiencies in a sampling procedure

NOTE An acceptable sampling error is one which does not lead to a significant loss in accuracy and precision of testing.

3 Apparatus

3.1 Scoop, made from minimum 0.8 mm thick non-corrodible metal suitable for taking standard scoopfuls of concrete.

NOTE A suitable scoop is shown in Figure 1.

3.2 Container for receiving concrete from the scoop, made of plastics or metal, of 9 L minimum capacity.

3.3 Sampling tray, minimum dimensions 900 mm × 900 mm × 50 mm deep, of rigid construction and made from a non-absorbent material not readily attacked by cement paste. (For use in the determination of sampling error, see clause 6.)

NOTE A larger size may be necessary for high workability concrete and when preparing samples for casting beams.

3.4 Square mouthed shovel, size 2 in accordance with BS 3388. (For use in determination of sampling error, see clause 6.)

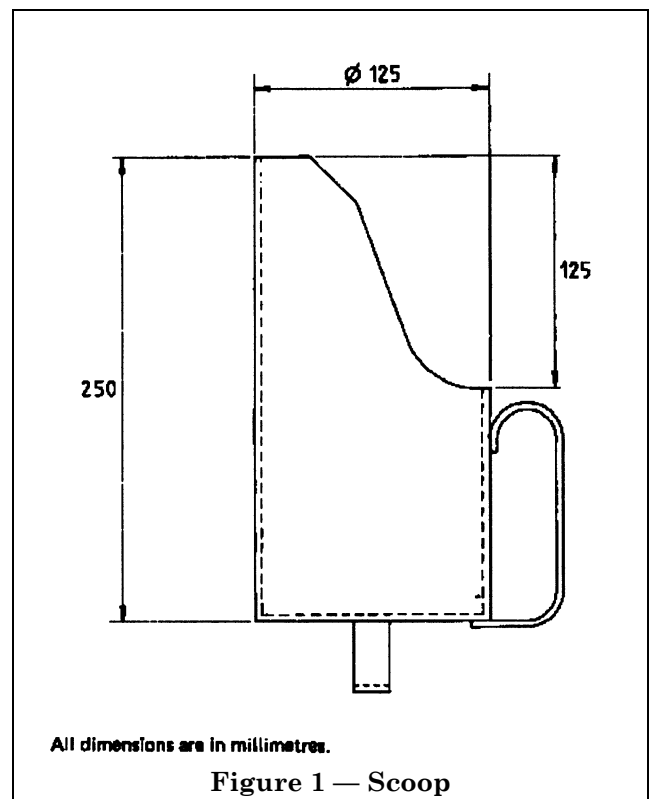

²⁾ BS 1881-1:1970 is under revision and will be replaced by BS 1881-125.

4 Sampling procedure

4.1 Sampling plan. Calculate the number of scoopfuls required for the test(s) by reference to Table 1. Nominally divide the batch to be sampled into this number of parts, each part being approximately equal in quantity. When sampling from a batch mixer or ready-mixed concrete truck disregard the very first part and very last part of the discharge. If the batch to be sampled has been deposited in a heap or heaps of concrete, the parts should wherever possible be distributed through the depth of the concrete as well as over the exposed surface.

NOTE When sampling from a ready-mixed concrete truck the division into parts can be on the basis of a given number of discharging revolutions of the drum. See also BS 1881-102 for an alternative method of sampling for the slump test.

Table 1 — Quantities of concrete required

Test or specimen	No. of standard scoopfuls
Slump	4
Compacting factor	6
Vebe time	4
Flow index	4
Air content	4
Density	6
100 mm cube (per pair of cubes)	4
150 mm cube (per pair of cubes)	4
100 mm × 100 mm × 500 mm beam (per pair of beams)	6
150 mm × 150 mm × 750 mm beam (per pair of beams)	18
150 mm × 300 mm long cylinder (per pair of cylinders)	6
100 mm × 200 mm long cylinder (per pair of cylinders)	4
75 mm × 75 mm × 300 mm prism (per pair of prisms)	4
150 mm × 150 mm long cylinders (per pair of cylinders)	4

NOTE For tests on concrete of very high workability, such as superplasticized concrete, see 4.2.

4.2 Obtaining the sample. Ensure that the apparatus is clean. Using the scoop obtain a scoopful of concrete from the central portion of each part of the batch and place in the container or containers. When sampling from a falling stream pass the scoop through the whole width and thickness of the stream in a single operation. Take the container(s) to the area where the sample is to be prepared for testing or mould filling.

NOTE Modifications may be necessary when obtaining samples of very high workability concrete (e.g. superplasticized concrete). A larger scoop than the standard scoop may be required to collect a scoopful of nominal 5 kg mass without spillage. Alternatively, a larger number of standard scoopfuls may be taken to obtain the required mass of concrete.

CAUTION. When cement is mixed with water, alkali is released. Take precautions to avoid dry cement entering the eyes, mouth and nose when mixing concrete. Prevent skin contact with wet cement or concrete by wearing suitable protective clothing. If cement or concrete enters the eye, immediately wash it out thoroughly with clean water and seek medical treatment without delay. Wash wet concrete off the skin immediately.

4.3 Protection of samples. At all stages of sampling, transport and handling, the fresh concrete samples shall be protected against gaining or losing water and against excessive temperatures.

5 Certificate of sampling

Each sample shall be accompanied by a certificate from the person responsible for taking the sample stating that sampling was carried out in accordance with this British Standard. The certificate shall include the following:

- a) date and time of sampling;
- b) name of works;
- c) location in the works of the concrete which the sample represents;
- d) location of sampling (e.g. on discharge from truck or from a heap of concrete);
- e) delivery note number or other means of identifying the batch;
- f) sample identity number;
- g) ambient temperature and weather conditions;
- h) name of sampler;
- i) signature of person responsible for sampling.

NOTE A standard certificate is shown in appendix A.

6 Determination of sampling error

6.1 General. The determination of sampling error is intended to provide a monitor of regular sampling or to assess the suitability of the standard method of sampling in unusual circumstances or for unusual materials.

Sampling error is assessed during regular sampling from the difference in compressive strength between duplicate samples with allowance for the contribution from testing error.

6.2 Procedure

6.2.1 General. From each of 20 batches of concrete of the same grade or mix obtain a standard sample and a duplicate sample using the procedure in clause 4. Each scoopful taken for the standard sample shall be followed immediately by a scoopful for the duplicate sample and the two samples shall be collected in separate containers. Prepare both the standard and the duplicate samples in accordance with 6.2.2 and make pairs of 150 mm cubes from each sample in accordance with BS 1881-108. Test all cubes for compressive strength at 28 day age in accordance with BS 1881-116.

6.2.2 Preparing the sample for test. Empty the sample from the container(s) onto the sampling tray. Ensure that no more than a light covering of slurry is left adhering to the container(s).

Thoroughly mix the sample by shovelling it to form a cone on the sampling tray and turning this over with the shovel to form a new cone, the operation being carried out three times. When forming the cones deposit each shovelful of the material on the apex of the cone so that the portions which slide down the sides are distributed as evenly as possible and so that the centre of the cone is not displaced. Flatten the third cone by repeated vertical insertion of the shovel across the apex of the cone, lifting the shovel clear of the concrete after each insertion.

NOTE The following modifications to the mixing procedure may be necessary when preparing samples of very high workability concrete (e.g. superplasticized concrete) for test.

- a) *Sampling tray.* The vertical lips on the edges of the tray may have to be larger to contain the sample without spillage during mixing.
- b) *Mixing the sample.* The coning procedure is not suitable for very high workability concrete and the following alternative method of mixing is recommended. Having poured the concrete onto the sampling tray, use the shovel to turn the concrete from the outside toward the centre, working progressively once round all sides of the sampling tray.

6.3 Calculation and reporting sampling error.

For each pair of compressive strength results from the 20 standard samples calculate the mean, M_s , and the differences, D_s . Similarly for each pair of compressive strength results from the 20 duplicate samples calculate the mean, M_d , and the differences, D_d . Record each calculation of the mean to the nearest 0.25 N/mm².

Calculate the following:

$$\text{Testing variance } (V_t) = \frac{\Sigma D_s^2 + \Sigma D_d^2}{80}$$

Testing plus sampling variance

$$(V_{ts}) = \frac{\Sigma (M_s - M_d)^2}{40}$$

$$\text{Mean strength } (M) = \frac{\Sigma M_s + \Sigma M_d}{40}$$

$$\text{Sampling error (in per cent)} = \frac{100 \sqrt{(V_{ts} - 0.5 V_t)}}{M}$$

$$\text{Testing error (in per cent)} = \frac{100 \sqrt{V_t}}{M}$$

Report sampling error and testing error to the nearest 0.1 %.

6.4 Assessment. If the estimate of the sampling error is greater than 3 %, then the sampling procedure shall be appraised. If the estimate of the testing error is above 3 %, then the testing procedure shall be appraised. If both estimates are less than 3 %, the sampling procedure can be assumed to be satisfactory.

NOTE The testing variance defined in 6.3 is related to the repeatability standard deviation in 7.3 of BS 1881-116:1983 by the equation.

$$s_r = \sqrt{V_{tmp}}$$

Appendix A
Certificate of sampling

The following is a standard certificate of sampling in accordance with this Part of this standard.

CERTIFICATE OF SAMPLING IN ACCORDANCE WITH BS 1881-101

Date and time of sampling

Name of works

Location in works of the concrete which the sample represents

Location of sampling (e.g. on discharge from truck or from a heap of concrete)

Delivery note number or other means of identifying the batch

Sample identity number

Ambient temperature and weather conditions

Name of sampler

The sampler certifies that sampling was done in accordance with BS 1881-101

.....
Signature of person responsible for sampling

Publications referred to

BS 1881, *Testing concrete*.

BS 1881-1, *Methods of mixing and sampling fresh concrete in the laboratory*.

BS 1881-102, *Method for determination of slump*.

BS 1881-108, *Method for making concrete test cubes*.

BS 1881-116, *Method for determination of compressive strength of concrete cubes*.

BS 1881-125, *Mixing and sampling fresh concrete in the laboratory*³⁾.

BS 3388, *Forks, shovels and spades*.

BS 5328, *Methods for specifying concrete, including ready-mixed concrete*.

³⁾ In course of preparation.

BSI — British Standards Institution

BSI is the independent national body responsible for preparing British Standards. It presents the UK view on standards in Europe and at the international level. It is incorporated by Royal Charter.

Revisions

British Standards are updated by amendment or revision. Users of British Standards should make sure that they possess the latest amendments or editions.

It is the constant aim of BSI to improve the quality of our products and services. We would be grateful if anyone finding an inaccuracy or ambiguity while using this British Standard would inform the Secretary of the technical committee responsible, the identity of which can be found on the inside front cover. Tel: 020 8996 9000. Fax: 020 8996 7400.

BSI offers members an individual updating service called PLUS which ensures that subscribers automatically receive the latest editions of standards.

Buying standards

Orders for all BSI, international and foreign standards publications should be addressed to Customer Services. Tel: 020 8996 9001. Fax: 020 8996 7001.

In response to orders for international standards, it is BSI policy to supply the BSI implementation of those that have been published as British Standards, unless otherwise requested.

Information on standards

BSI provides a wide range of information on national, European and international standards through its Library and its Technical Help to Exporters Service. Various BSI electronic information services are also available which give details on all its products and services. Contact the Information Centre. Tel: 020 8996 7111. Fax: 020 8996 7048.

Subscribing members of BSI are kept up to date with standards developments and receive substantial discounts on the purchase price of standards. For details of these and other benefits contact Membership Administration. Tel: 020 8996 7002. Fax: 020 8996 7001.

Copyright

Copyright subsists in all BSI publications. BSI also holds the copyright, in the UK, of the publications of the international standardization bodies. Except as permitted under the Copyright, Designs and Patents Act 1988 no extract may be reproduced, stored in a retrieval system or transmitted in any form or by any means – electronic, photocopying, recording or otherwise – without prior written permission from BSI.

This does not preclude the free use, in the course of implementing the standard, of necessary details such as symbols, and size, type or grade designations. If these details are to be used for any other purpose than implementation then the prior written permission of BSI must be obtained.

If permission is granted, the terms may include royalty payments or a licensing agreement. Details and advice can be obtained from the Copyright Manager. Tel: 020 8996 7070.